

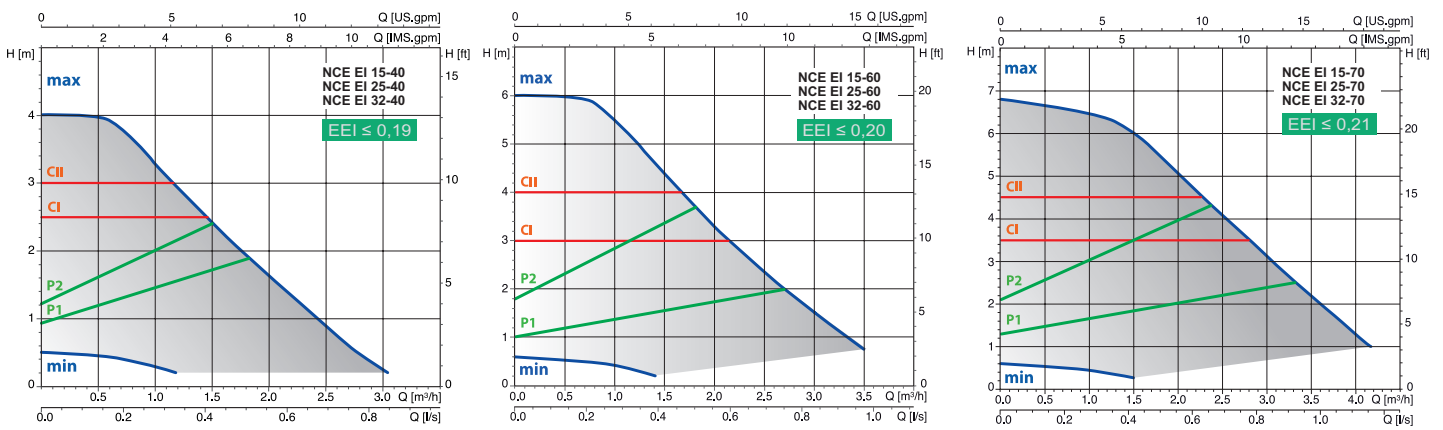

Coverage chart n ≈ 2900 rpm



CI-CII curva costante

P1-P2 curva proporzionale

min-max n curve fisse

Energy saving Circulating Pumps with frequency converter

Construction

Energy saving variable speed circulating pump driven by a permanent magnet synchronous motor (pm) controlled by on board inverter.

Applications

- Small domestic heating systems.
- Floor heating systems.
- Liquid temperature from +2 °C to +95 °C
- Ambient temperature from 0 °C to +40 °C
- Maximum permissible working pressure: 6 bar
- Storage: -20°C/+70°C max. relative humidity 95% at 40 °C
- Certifications: in conformity with CE requirements
- Sound pressure ≤ 43 dB (A).
- Minimum suction pressure: 0,3 bar at 50 °C 1,0 bar at 95 °C
- Maximum glycol quantity: 40%
- EMC according to: EN 55014-1, EN 61000-3-2, EN 55014-2
- Connections: threaded ports ISO 228: G 1, G 1 1/2, G 2
- The benchmark for most efficient circulators is EEI ≤ 0,20.
- Minimum power: 3 W.

Operating conditions

- Liquid temperature from +2 °C to +95 °C
- Ambient temperature from 0 °C to +40 °C
- Maximum permissible working pressure: 6 bar
- Storage: -20°C/+70°C max. relative humidity 95% at 40 °C
- Certifications: in conformity with CE requirements
- Sound pressure ≤ 43 dB (A).
- Minimum suction pressure: 0,3 bar at 50 °C 1,0 bar at 95 °C
- Maximum glycol quantity: 40%
- EMC according to: EN 55014-1, EN 61000-3-2, EN 55014-2
- Connections: threaded ports ISO 228: G 1, G 1 1/2, G 2
- The benchmark for most efficient circulators is EEI ≤ 0,20.
- Minimum power: 3 W.

Motor

- Synchronous motor with permanent magnet.
 - Motor: variable speed
 - Standard voltage: single-phase 230 V (-10%;+6%)
 - Frequency: 50-60 Hz
 - Protection: IP 44
 - Insulation class: H
 - Class II appliance
 - Overload protection (integrated).
 - 1) automatic protection with electronic rotor release
 - 2) Overload thermal protector
 - Cable: phases and neutral.
- Constructed in accordance with EN 60335-1, EN 60335-2-51.

Special features on request

- Brass or cast iron unions.
- EPP thermal insulation shell.

Designation

- NCE EI 32 - 60 / 180**
- NCE** = Series
- EI** = Version
- 32** = DN ports in mm
- 60** = Max. head in dm
- 180** = connection size mm

Features

Compact design

The space saving NCE EI is a very compact circulating pump, allows inr easy installation in small domestic heating systems.

Easy to install and to adjust

Installing the NCE EI is considerably simplified by the quick setting and power installation plug.

Reliable

Like all our electronic circulating pumps, the NCE EI features the patented self-cleaning square chamber design, which eliminates any possibility of rotor blockage.

Ceramic shaft

Hydraulics components are completely painted with cataphoresis.

Program for automatic venting and unblocking routines.

Easy use

Operating range with fixed curves from 0,5 m to 7 m; possibility to choose 2 (1-2) proportional pressure curves and 2 (I-II) constant pressure curves.

Materials

Component	Material
Pump casing	Cast iron GJL 200 EN 1561
Impeller	Composite
Shaft	Ceramic
Ball bearings	Carbon
Thrust bearing	Ceramic
Rotor	Composite / Ferrite
Winding	Copper wire
Electronic card	-
Gasket	EPDM

Operating modes



PROPORTIONAL CURVE PROGRAMMING $\Delta p-v$
(GREEN LED)
Moving the switch to 1 or 2 setting, the pump operates with the proportional curve.
This mode ensures maximum energy efficiency.



CONSTANT CURVE PROGRAMMING $\Delta p-c$
(ORANGE LED)
Moving the switch to I or II setting, the pump operates with a constant curve according to the selected flow rates.



MANUAL PROGRAMMING
(BLUE LED)
Setting the switch in any position between the MIN and MAX points, the most suitable operating curve for the installation is manually selected.

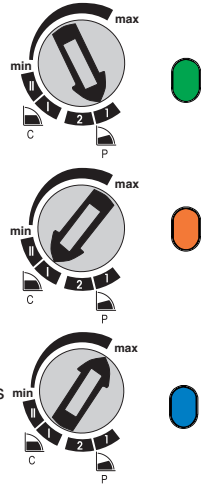

WARNING!
- The red LED indicates that the pump is not rotating but is still under tension.
- White flashing LED : plant degassing requirement, air in the system.

Dimensions and weights

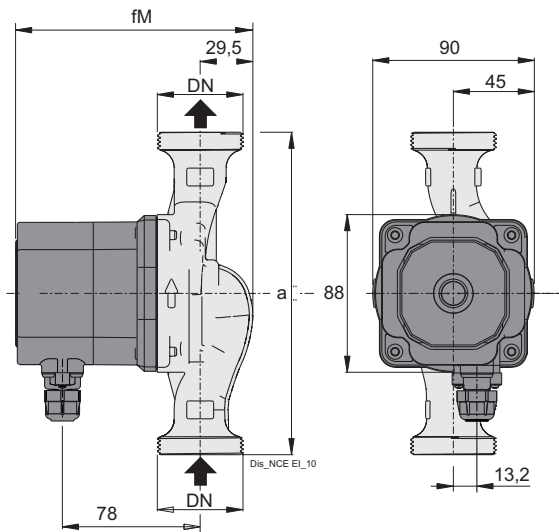

TYPE	DN	230V		P1		mm	mm	kg
		A max	A min	W max	W min	fM	a	
NCE EI 15-40/130	G 1	0,17	0,03	22	3	134	130	1,67
NCE EI 25-40/130	G 1 1/2	0,17	0,03	22	3	134	130	1,81
NCE EI 25-40/180	G 1 1/2	0,17	0,03	22	3	134	180	1,96
NCE EI 32-40/180	G 2	0,17	0,03	22	3	134	180	2,10
NCE EI 15-60/130/A	G 1	0,33	0,03	42	3	134	130	1,67
NCE EI 25-60/130/A	G 1 1/2	0,33	0,03	42	3	134	130	1,81
NCE EI 25-60/180/A	G 1 1/2	0,33	0,03	42	3	134	180	1,96
NCE EI 32-60/180/A	G 2	0,33	0,03	42	3	134	180	2,10
NCE EI 15-70/130	G 1	0,44	0,03	56	3	144	130	1,91
NCE EI 25-70/130	G 1 1/2	0,44	0,03	56	3	144	130	2,05
NCE EI 25-70/180	G 1 1/2	0,44	0,03	56	3	144	180	2,20
NCE EI 32-70/180	G 2	0,44	0,03	56	3	144	180	2,34

Unions (on request)

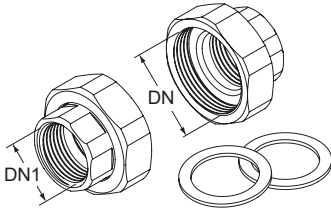

TYPE	DN	DN1
KIT G 1 - G 1/2 (NCE . 15..)	G 1	G 1/4
KIT G 1 1/2 - G 1 (NCE . 25..)	G 1 1/2	G 1
KIT G 2 - G 1 1/4 (NCE . 32..)	G 2	G 1 1/4

Examples of installations

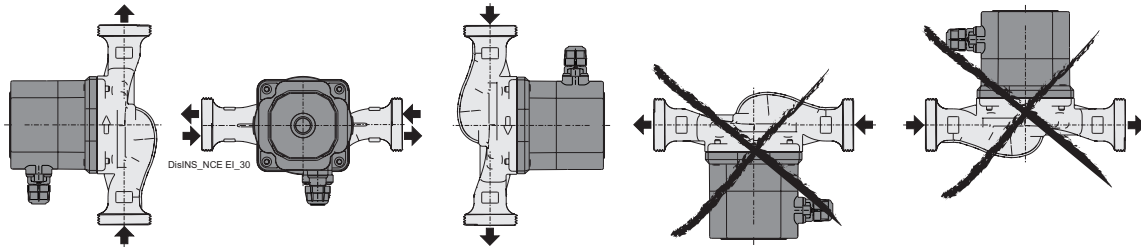

Terminal box arrangement (on request)

