

HS

Version 5

Horizontal split case pumps
60 Hz

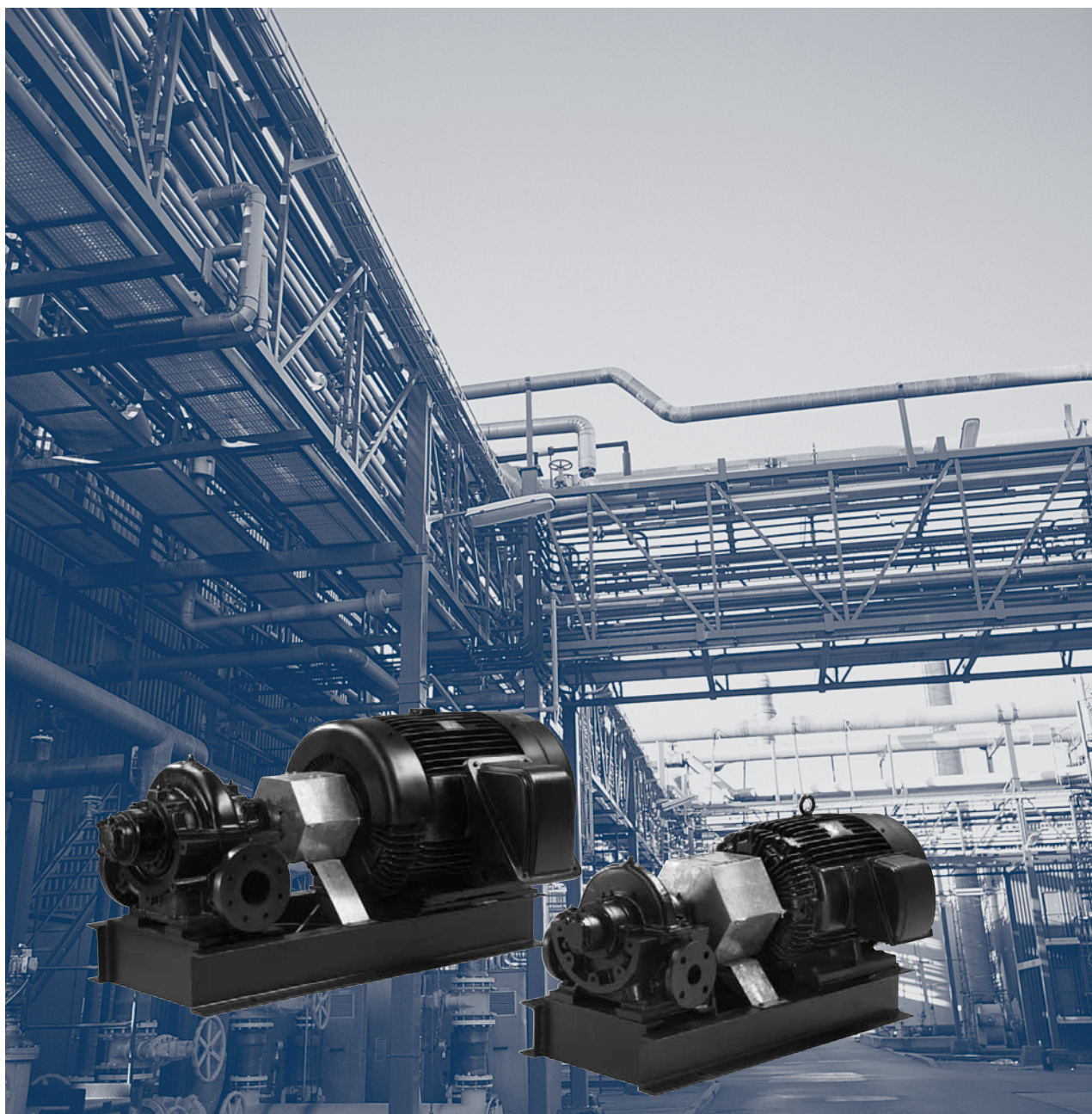

Contents

Introduction

Applications

Commercial systems	4
Industrial systems	4
Water distribution	4
Irrigation and aquaculture	4

Features and benefits

Performance range

HS 2-pole	6
HS 4-pole	7
HS 6-pole	8
Performance curves - overview	9

Product range

Pump configurations	10
Pump range	11

Identification

Nameplate	12
Type key	12
Mechanical shaft seals	13
Stuffing boxes	13

Construction

HS pump, construction type 1	15
HS pump, construction type 2	16
HS pump, construction type 3	17
HS pump, construction type 4	18
HS pump, typical end view	19
Standard components and material specification	20
Mechanical construction	21

Operating conditions

Ambient temperature and altitude	24
Liquid temperatures	24
Shaft seal	24
Pressure	25
Flow	25

Installation

Mechanical installation	26
General installation guidelines	26
Vibration dampers	27
Expansion joints	27
Location	27
Foundation	27
Grouting	27
Measuring instruments	28
Piping	28
Suction piping	29
Discharge piping	31
Auxiliary piping	31

Selection of product

Pump size	32
Efficiency	32
Material	32
Motor size	32
Where to find the information	33

Pumped liquids

Pumped liquids	35
Liquid density and viscosity	35

Electrical data

2-pole motors	36
4-pole motors	36
6-pole motors	37

Curve charts and technical data

How to read the curve charts	38
Curve conditions	39
Performance tests	39
Certificates	39
Witness test	39

Performance curves

Technical data

2-pole	40
4-pole	48
6-pole	92

Bare shaft pump

Dimensional sketch	112
--------------------	-----

Accessories

Suction diffuser	114
Lubricator	116
Pt 100 sensor	116

Further product documentation

WebCAPS	117
WinCAPS	118

Horizontal split case pumps have horizontal pump shaft, and the pump casing can be dismantled in the horizontal plane along the drive shaft.

The Grundfos horizontal split case pumps, type HS version 5, are single-stage, non-self-priming, centrifugal volute pumps with radial suction and radial discharge port.

The split case construction enables removal and dismantling of the internal pump parts, e.g. bearings, wear rings, impeller and shaft seal, without disturbing the motor or pipework.



GrA703

Fig. 1 Grundfos single-stage HS pump, version 5

Variants

Grundfos HS pumps are available in these variants:

- pump with motor and base frame
- bare shaft pump with base frame
- bare shaft pump.

The Grundfos HS pumps are used in these main fields of application:

- commercial systems
- industrial systems
- water distribution
- irrigation.

Commercial systems

Liquid transfer and pressure boosting in:

- air conditioning, primary and secondary chilled water systems
- water condensing systems and cooling towers
- high-rise buildings
- boiler feed and condensate systems
- district heating plants and heating systems
- swimming pools
- fountains.

Industrial systems

Liquid transfer and pressure boosting in:

- process cooling and chilled water systems
- water condensing systems and cooling towers
- boiler feed and condensate systems
- industrial heating systems
- washdown and cleaning systems
- industrial processing systems (water, light chemicals, oils, etc).

Water distribution

Liquid transfer and pressure boosting in:

- public waterworks
- non-potable water systems.

Irrigation and aquaculture

Irrigation covers these applications:

- field irrigation (flooding)
- sprinkler irrigation
- drip-feed irrigation
- aquafarming.

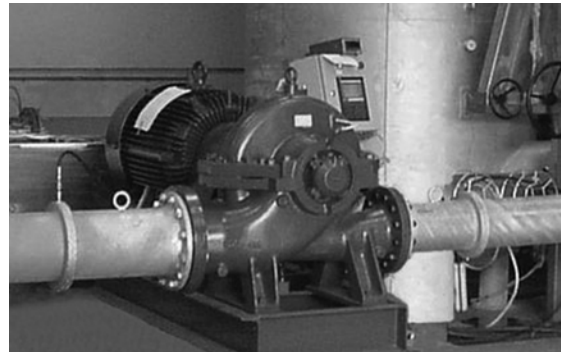

TM03 3903 1106

Fig. 2 HS pump in industrial pressure boosting



GF 2910

Fig. 3 HS pump in sprinkler irrigation

Grundfos HS pumps present these features and benefits:

- The pumps are non-self-priming, centrifugal volute pumps with radial suction and radial discharge ports and horizontal shaft.
- Suction and discharge flanges are PN 16 according to EN 1092-2 (DIN2501). The pumps are also available with PN 10 flanges for the low pressure range.
- The pump is long-coupled with a totally enclosed fan-cooled standard motor with main dimensions to IEC and DIN standards and mounting designation B3 (IM 1001).
- The mechanical shaft seal has dimensions according to EN 12756.
- HS pumps cover this performance range:
Flow rate: 10 to 2700 m³/h.
Head: 5 to 215 m.
Motor: 2.2 - 600 kW.
- The rotating assembly is dynamically balanced according to ISO 1940 class G6.3.
- Impellers are hydraulically balanced.
- Pump and motor are mounted on a common base frame in the form of a welded, steel C-channel profile.
- The split case construction enables removal and dismantling of the internal pump parts, e.g. bearings, wear rings, impeller and shaft seal, without disturbing the motor and pipework.
- Grundfos HS pumps are available in three different variants:
 1. Pump with motor and base frame.
 2. Bare shaft pump with base frame.
 3. Bare shaft pump, i.e. pump without motor and without base frame.
 See figs. 4, 5 and 6.

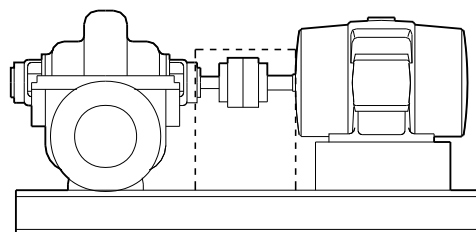

Fig. 4 HS pump with motor and base frame

TM04 0473 0708

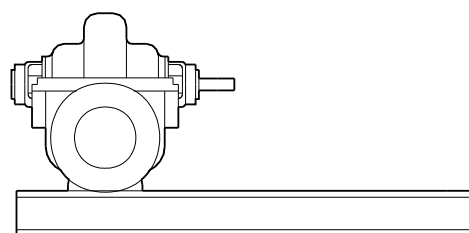

Fig. 5 HS bare shaft pump with base frame

TM04 0474 0708

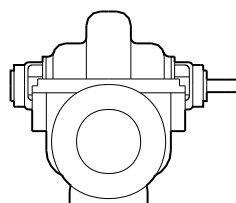

Fig. 6 HS bare shaft pump

TM04 0572 0808

Grundfos HS pumps are available with 2-, 4- or 6-pole motors.

The next three pages show the performance range covered by these three motor types.

Knowing your required duty point, use the performance ranges like this:

1. Go into the relevant performance range chart.
2. Find your duty point.
3. Note which pump type covers your duty point.
4. Go to section "Product range" and then to "Performance curves and technical data" and find more detailed information on your chosen pump.

HS 2-pole

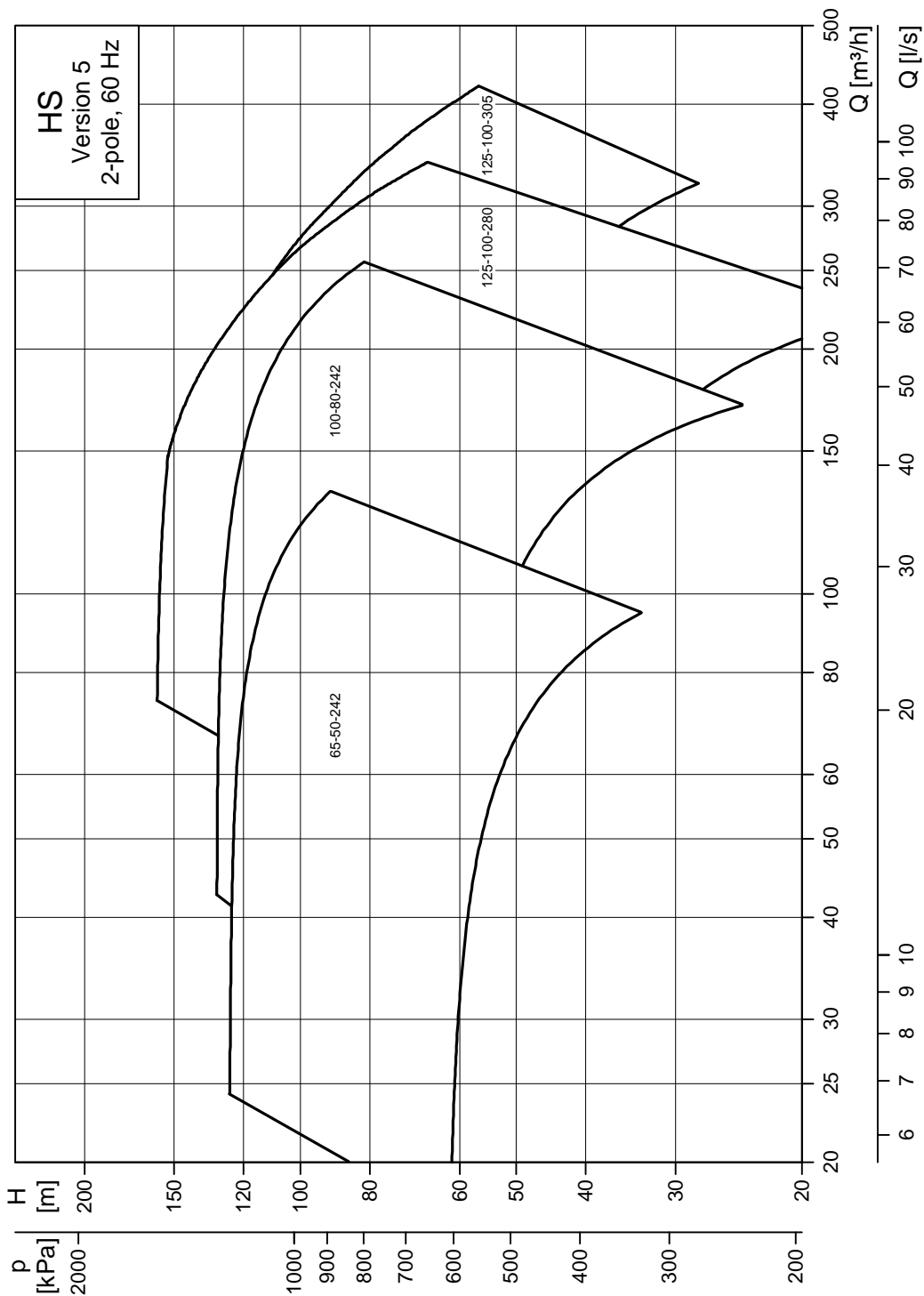

TM03 9882 2308

Performance range

HS

HS 4-pole

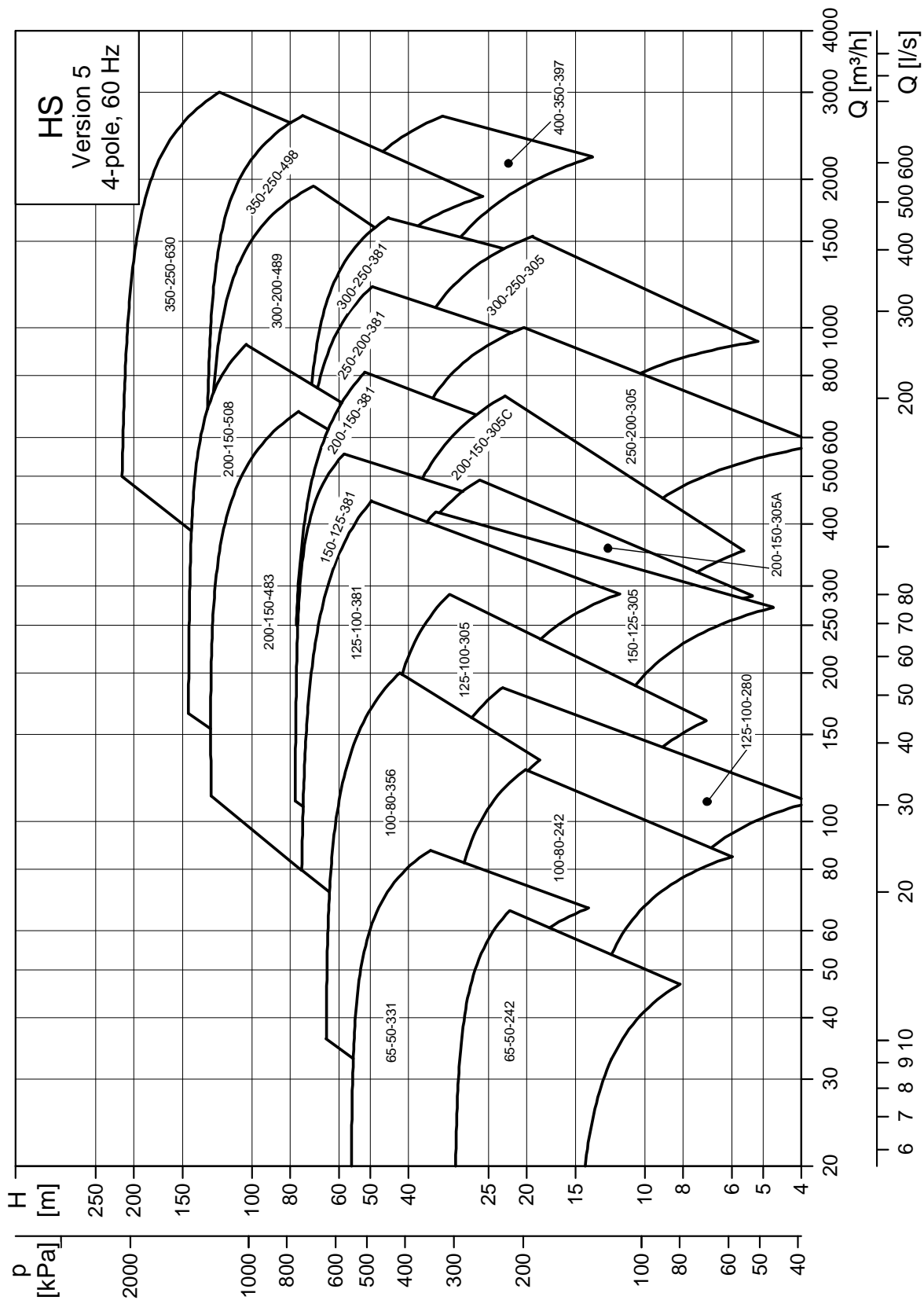

TM04 0300 2308

HS 6-pole

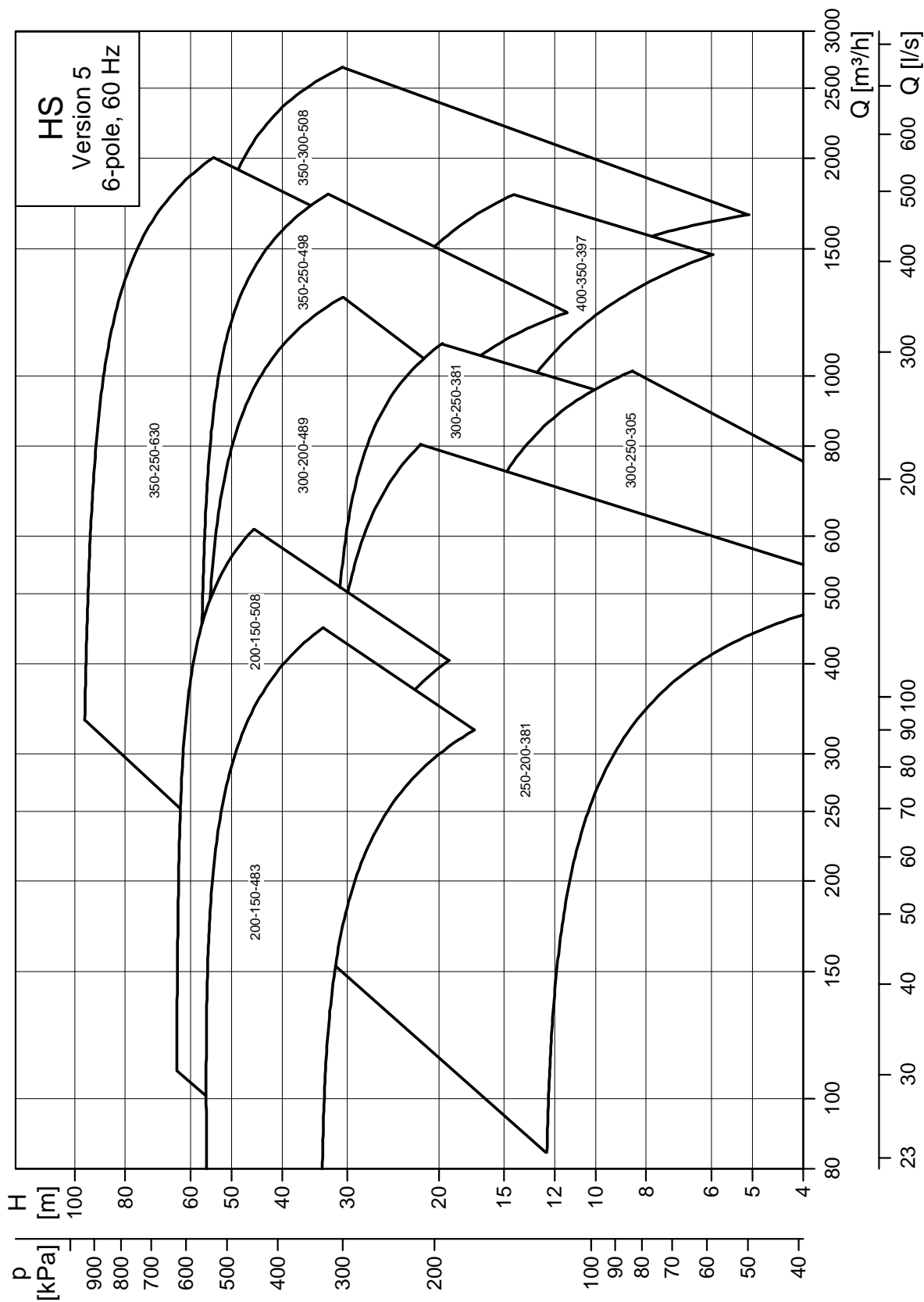

TM04 0301 2308

Performance curves - overview

Pump type	Page reference		
	2-pole	4-pole	6-pole
HS65-50-242	40	48	-
HS65-50-331	-	50	-
HS100-80-242	42	52	-
HS100-80-356	-	54	-
HS125-100-280	44	56	-
HS125-100-305	46	58	-
HS125-100-381	-	60	-
HS150-125-305	-	62	-
HS150-125-381	-	64	-
HS200-150-305A	-	66	-
HS200-150-305C	-	68	-
HS200-150-381	-	70	-
HS200-150-483	-	72	92
HS200-150-508	-	74	94
HS250-200-305	-	76	-
HS250-200-381	-	78	96
HS300-200-489	-	80	98
HS300-250-305	-	82	100
HS300-250-381	-	84	102
HS350-250-498	-	86	104
HS350-250-630	-	88	106
HS350-300-508	-	-	108
HS400-350-397	-	90	110

Pump configurations

	Standard configuration	Optional configuration
Pump casing	Ductile iron (PN 16)	Cast iron (PN 10)
Impeller	Bronze	<ul style="list-style-type: none"> Aluminium bronze Stainless steel
Sleeve	Bronze	Stainless steel
Coupling	Flexible grid	-
Shaft seal	Mechanical seal: BBVP	Mechanical seal: <ul style="list-style-type: none"> BBQV Stuffing box: <ul style="list-style-type: none"> SNEK, (internal flushing/recirculation line is included)
Flange	EN 1092-2 (DIN 2501), PN 16	<ul style="list-style-type: none"> EN 1092-2 (DIN 2501), PN 10 ANSI 125 ANSI 250
Flushing line	-	Nylon
Motor efficiency class	EFF 1	EFF2
Pump direction of rotation	CW - clockwise	CCW - counter clockwise

To a great extent the pumps can be adapted to the requirements of the individual customer. For customised solutions, contact your local Grundfos company.

Pump range

The table below gives an overview of the HS pump, version 5 range. The table shows the complete PN 16 pump range. The PN 10 pump range does not include all impeller sizes (see individual performance curves).

The product range includes the pumps established in WebCAPS.

HS pumps are available with 2-, 4- or 6-pole motors; other pole numbers are available on request.

HS pumps are available in four different construction types, all with mechanical shaft seal.

Pump sizes	Motor range [kW]			Construction type ¹⁾			
	2-pole	4-pole	6-pole	1	2	3	4
HS65-50-242	18.5-75	2.2-11	-	●			
HS65-50-331	-	7.5-22	-	●			
HS100-80-242	30-110	4-15	-	●		●	
HS100-80-356	-	11-45	-		●		
HS125-100-280	30-110	3.7-22	-		●		
HS125-100-305	55-110	7.5-45	-		●		
HS125-100-381	-	18.5-110	-		●		
HS150-125-305	-	11-55	-		●		
HS150-125-381	-	22-132	-		●		
HS200-150-305A	-	11-75	-		●		
HS200-150-305C	-	15-75	-		●		
HS200-150-381	-	30-200	-			●	
HS200-150-483	-	90-250	30-75			●	●
HS200-150-508	-	110-450	37-132				●
HS250-200-305	-	22-110	-			●	
HS250-200-381	-	45-250	15-75			●	
HS300-200-489	-	200-600	55-200				●
HS300-250-305	-	45-160	15-45			●	
HS300-250-381	-	110-315	30-90			●	
HS350-250-498	-	250-600	75-250				●
HS350-250-630	-	450-600	132-450				●
HS350-300-508	-	-	90-355				●
HS400-350-397	-	200-400	55-110				●

1) For further information on the various constructions, see Construction. Construction types may differ for pumps with stuffing box.

For electrical data, see page 36.

Nameplate

The nameplate on the pump gives the details of the pump:

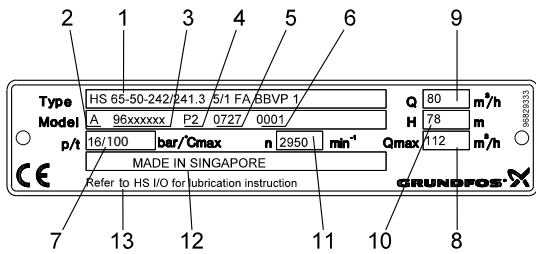

TM04 2243 2708

Fig. 7 Nameplate of HS pump version 5

Pos.	Description
1	Type designation
2	Model
3	Product number
4	Place of production
5	Production year and week
6	Serial number
7	Maximum pressure and temperature
8	Maximum flow rate
9	Rated flow rate
10	Head at rated flow rate
11	Speed
12	Country of production
13	Reference to HS installation and operating instructions for bearing lubrication

Type key

	HS	125	-100	-305x	/273.1	5/1	F	A	BBVP	1
Type range										
Nominal diameter of suction port										
Nominal diameter of discharge port										
Maximum impeller diameter (If suffix is used, "x" = different impeller design)										
Actual impeller diameter										
Pump version 5/ Pump variant:										
Code for pipework connection:										
Code for materials (pump casing and impeller):										
Code for shaft seal or stuffing box:										
Direction of rotation:										

/1=Pump with motor and base frame
 /2=Bare shaft pump with base frame
 /3=Bare shaft pump
 F=EN flange (to EN 1092-2)
 G=ANSI flange (to ANSI 125/250)
 A=Ductile iron pump casing with bronze impeller
 B=Cast iron pump casing with bronze impeller
 Q=Ductile iron pump casing with stainless steel impeller
 S=Cast iron pump casing with stainless steel impeller
 BBVP
 BBQV
 SNEK
 1=Clockwise
 2=Counter-clockwise

The example shown is an HS 125-100-305/273.1, standard type with standard coupling, EN 1092-2 flange, ductile iron pump casing with bronze impeller, BBVP mechanical shaft seal and clockwise direction of rotation.

Mechanical shaft seals

The HS pumps are supplied with a BBVP shaft seal as standard.

This shaft seal is available on request:

- BBQV

Codes for mechanical shaft seal

The positions (1) - (4) cover four pieces of information about the mechanical shaft seal:

Example	(1)	(2)	(3)	(4)
Grundfos type designation				
Material, rotating seal face				
Material, stationary seat				
Material, secondary seal and other rubber and composite parts				

The following table explains the positions (1), (2), (3) and (4).

Pos.	Type	Short description of seal
(1)	B	Bellows seal, rubber
		Material
(2)	B	Carbon, resin-impregnated
and	Q	Silicon carbide (of the dense type)
(3)	V	Aluminium oxide
		Material
(4)	P	Nitrile rubber (NBR)
	V	FKM (Viton™)

The mechanical shaft seal variant codes are used when stamping the nameplates for identification.

Stuffing boxes

Stuffing boxes of the type SNEK are available as an alternative to mechanical shaft seals.

Codes for stuffing box

Pos.	Code	Short description of stuffing box
1	S	Stuffing box with packing rings
		Cooling method
2	N	Uncooled stuffing box
		Barrier fluid
3	E	With internal barrier fluid
4	K	Synthetic polymer packing rings, graphite impregnated. NBR O-ring in the pump

Grundfos HS horizontal split case pumps are available in four different construction types.

Pages 15 to 20 show sectional views, typical end view, component list and material specifications of the basic versions with mechanical shaft seals.

All four construction types are available with stuffing boxes with packing rings as an option.

There are small differences within each construction type. For further information, see detailed exploded views of all variants in WebCAPS.

Pages 21 to 23 describe the mechanical construction in detail.

HS pump, construction type 1

Sectional view

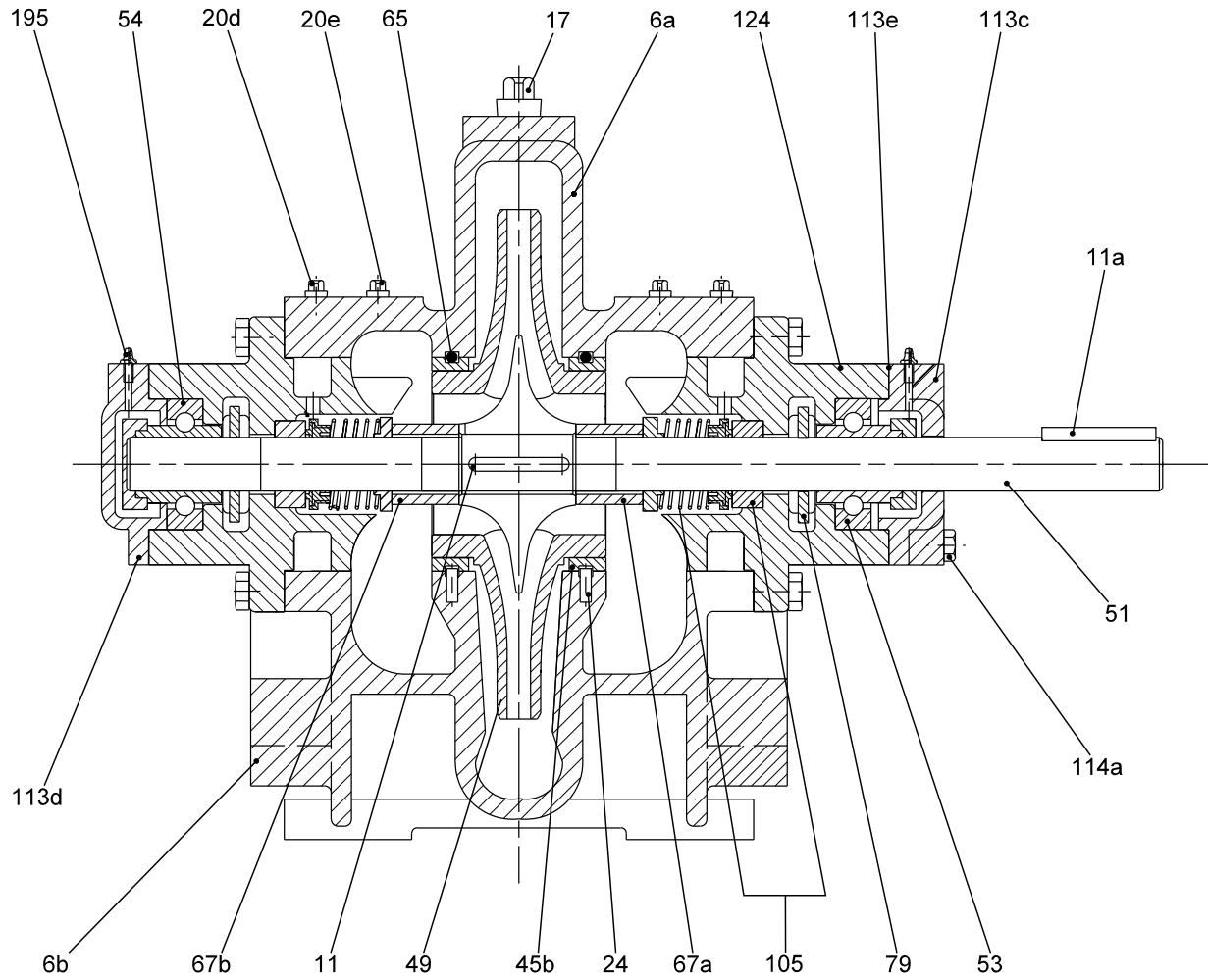

TM03 9952 4707

Fig. 8 Sectional view, construction type 1, with mechanical shaft seals

HS pump, construction type 2

Sectional view

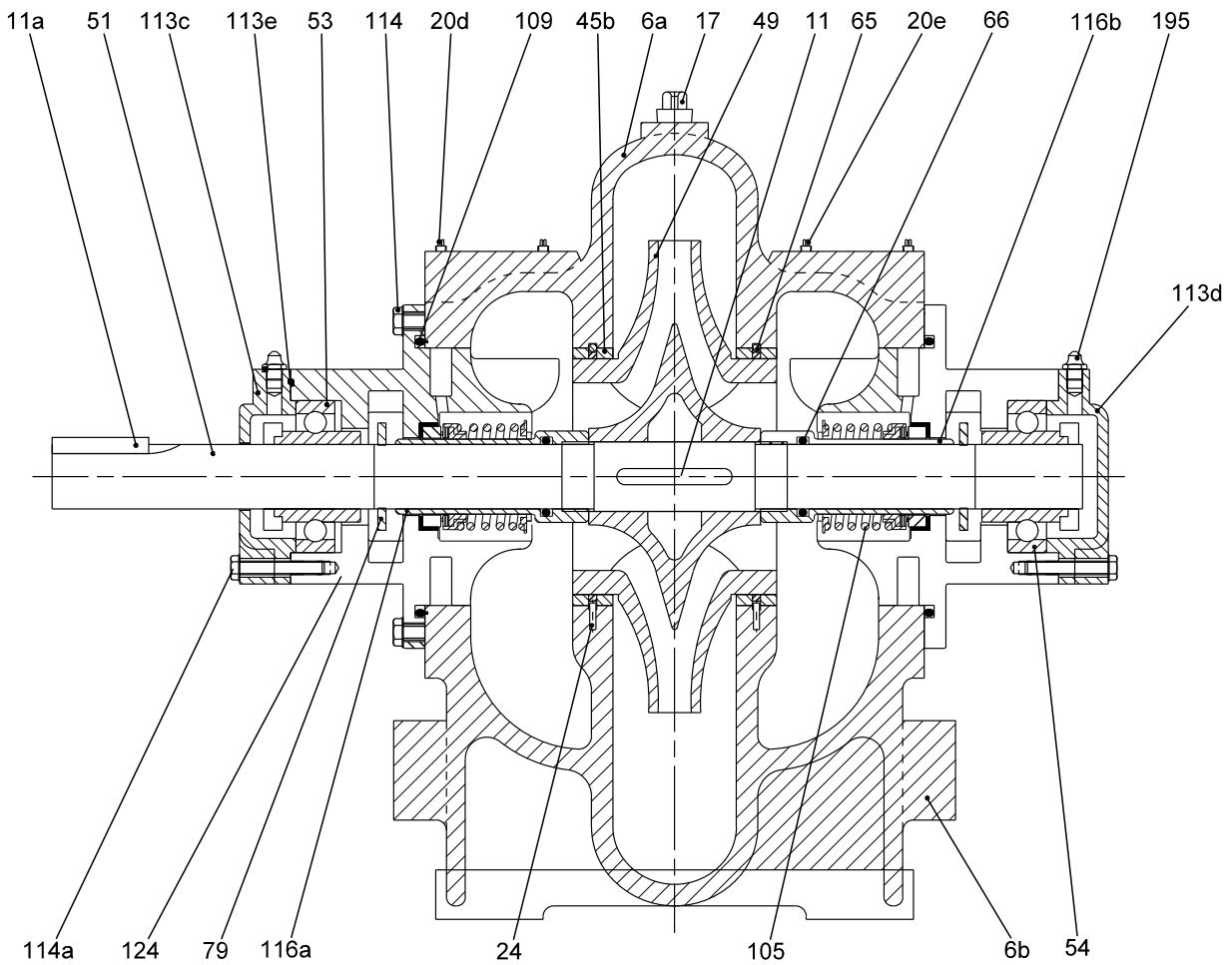
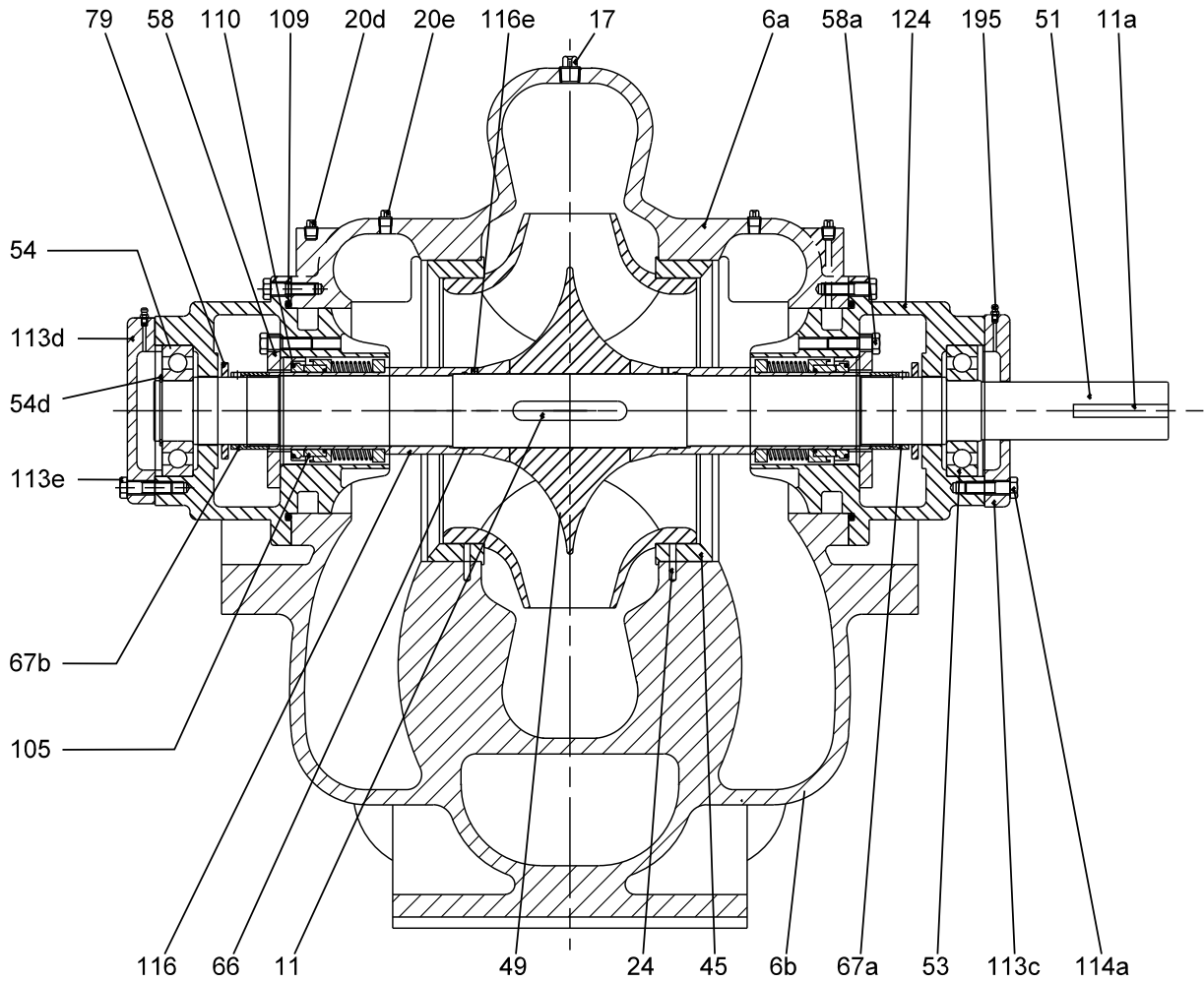

Fig. 9 Sectional view, construction type 2, with mechanical shaft seals

TM03 9953 4707

HS pump, construction type 3

Sectional view



TM03 9954 4707

Fig. 10 Sectional view, construction type 3, with mechanical shaft seals

HS pump, typical end view

(Non-drive end)

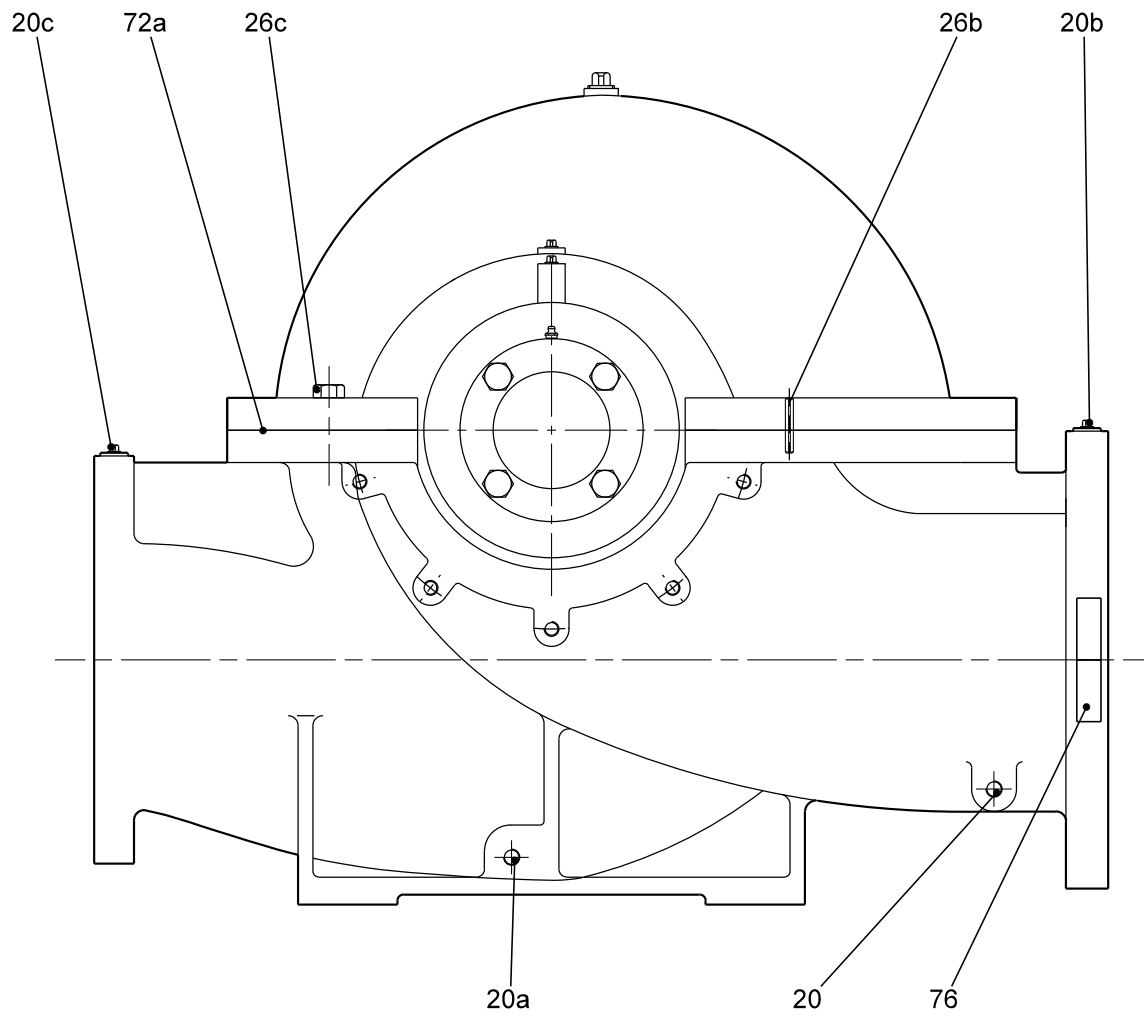

TM04 1864 1108

Fig. 12 Typical end view (non-drive end)

Standard components and material specification

Pos. no.	Component	Material	ASTM standard
6a	Pump casing, upper	Ductile iron	ASTM A536, 65-45-12
6b	Pump casing, lower	Ductile iron	ASTM A536, 65-45-12
11	Key, impeller	Steel	C1018, cold drawn steel
11a	Key, coupling	Steel	C1018, cold drawn steel
17	Air vent screw	Steel	
20	Drain plug R 1/2	Steel	
20a	Plug, drain outlet	Steel	
20b	Plug, inlet	Steel	
20c	Plug, outlet	Steel	
20d	Plug, shaft seal flushing	Steel	
20e	Plug, suction chamber	Steel	
24	Locking pin, wear ring	Steel	ANSI/ASME B18.8
26b	Roll pin	Steel	ANSI/ASME B18.8
26c	Screw	Steel	
45	Wear ring	Bronze	ASTM B148, C95200
45b	Wear ring with groove for retaining ring	Bronze	ASTM B148, C95200
49	Impeller	Silicon bronze	ASTM B584, C87600
51	Shaft	Stainless steel	AISI 420
53	Ball bearing, drive end	Steel	
54	Ball bearing, non-drive end	Steel	
54c	Washer	Steel	
54d	Retaining ring	Carbon Spring Steel	SAE 1060-1090
58	Seal cover	Grey Iron	
58a	Screw	Steel	
65	Retaining ring	Stainless steel, series 303	
66	O-ring	NBR	
67a	Impeller/shaft sleeve nut, right-hand thread	Bronze	III932, C89835
	Impeller/shaft lock nut, right-hand thread	Stainless steel	
67b	Impeller/shaft sleeve nut, left-hand thread	Bronze	III932, C89835
	Impeller/shaft lock nut, left-hand thread	Stainless steel	
72a	Gasket	Vegetable fiber (HYD-401)	
76	Nameplate	Aluminum	
79	Slinger	Neoprene	
105	Shaft seal		
109	O-ring	NBR	
109a	O-ring	NBR	
110	O-ring	NBR	
113	Bearing housing	Ductile iron	ASTM A536, 65-45-12
113c	Bearing cover, drive end	Cast iron	ASTM A48, CL30
113d	Bearing cover, non-drive end	Cast iron	ASTM A48, CL30
113e	Gasket	Vegetable fiber (HYD-401)	
113f	Lip seal, non-drive end bearing	NBR	
113g	Lip seal, drive-end bearing	NBR	
114	Screw	Steel	
114a	Screw	Steel	
114b	Screw	Steel	
116	Shaft sleeve	Bronze	III932, C89835
116a	Shaft sleeve, drive end	Bronze	I836 C89833
116b	Shaft sleeve, non-drive end	Bronze	I836 C89833
116c	Shaft sleeve, inner	Bronze	I836 C89833
116d	Shaft sleeve, outer	Bronze	I836 C89833
116e	Set screw	Steel	
124	Seal housing	Ductile iron	ASTM A536, 65-45-12
195	Lubricating nipple	Zinc coated steel	

Mechanical construction

Pump casing

The ductile iron volute pump casing has radial suction port and radial discharge port.

The pumps are of the inline (symmetric) design.

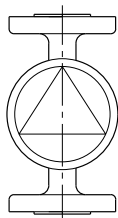

TM04 0476 0708

Fig. 13 Schematic drawing of an inline HS pump

Flange dimensions are in accordance with EN 1092-2 (DIN 2501).

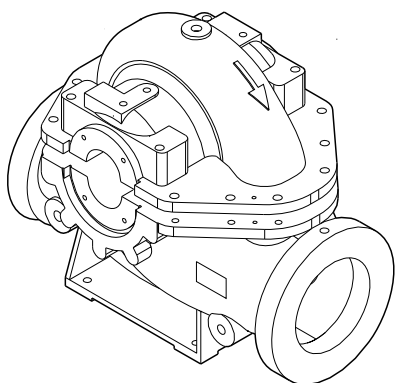

TM04 0475 0708

Fig. 14 Upper and lower pump casing of HS pump

Shaft

The shaft (pos. 51) is of the key and keyway type with one key for the impeller (pos. 11) and one key for the coupling (pos. 11a).

The shaft is supported by bearings at both the drive end and the non-drive end of the pump.

The shaft is made of stainless steel (AISI 420).

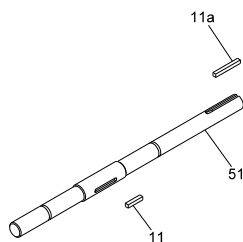

TM04 0477 0708

Fig. 15 HS pump shaft

Shaft sleeves are attached to the pump shaft to prevent wear of the shaft and secure the position of the impeller.

Bearings

HS pumps are fitted with two standard single-row deep-groove ball bearings. The bearings are of the open type permitting the bearings to be relubricated. The bearings are lubricated by Grundfos prior to delivery.

Seal housings

All HS pumps have two seal housings (pos. 124), one at the drive end and one at the non-drive end of the pump shaft.

A seal housing has several functions:

- It supports the pump sealing system, whether it is a mechanical shaft seal or a stuffing box.
- It supports the bearing housing thus transmitting both radial and axial forces from bearing and shaft to the upper and lower pump casing.
- It has connection for the flushing pipe.

The function of the flushing pipe is to ensure a flow of pumped liquid for cooling and lubricating the mechanical shaft seal or the stuffing box.

Note: This feature is optional for mechanical shaft seals.

Impeller

The HS impeller (pos. 49) is a closed double-suction impeller. The impeller has inflow of liquid from both sides and is locked in position by a threaded sleeve arrangement.

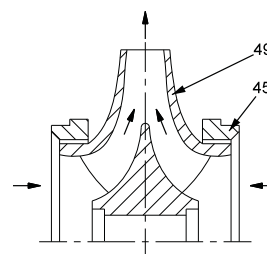

TM03 3891 1106

Fig. 16 Double-suction impeller

All impellers are dynamically balanced in accordance with ANSI/ISO 1940 Class G6.3 standard. Due to their design, the impellers are inherently hydraulically balanced and thus compensate for axial thrust.

All impellers are trimmed to the duty point required by the customer and dynamically balanced together with the shaft.

Wear rings

HS pumps have wear rings (pos. 45) between impeller and pump casing.

As the name indicates, the wear rings protect the pump casing against wear. Besides, the wear rings have a sealing function between impeller and pump casing.

When the wear rings become worn, the efficiency of the pump will be reduced, and the wear rings should be replaced.

Coupling

As standard, HS pumps are fitted with a flexible grid coupling.

The coupling consists of two steel flanges with tapered teeth and a grid spring to transmit the torque. The coupling is held together by means of horizontally split coupling halves.

The coupling design assists in reducing vibrations and cushions shock loads. The design also extends the life of the coupling itself.



TM04 0478 0708

Fig. 17 Flexible grid coupling

A fully enclosing coupling guard is mounted between the pump and the motor and firmly attached to the base.

Mechanical shaft seal

The shaft seal is a mechanical shaft seal with dimensions to EN 12756.

The code of the standard version is BBVP.

For other mechanical shaft seal variants, see page 13 or contact Grundfos.

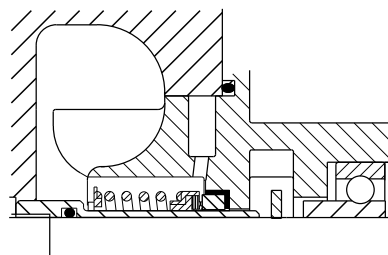

TM04 0472 0708

Fig. 18 Rubber bellows shaft seal, type B

Stuffing box

The stuffing box includes graphite impregnated packing rings.

The packing rings consist of braided material which is effective for ensuring long service life for packing rings while protecting the shaft (sleeve). When fitted, the packing rings are symmetrical, having parallel facings that prevent tilting.

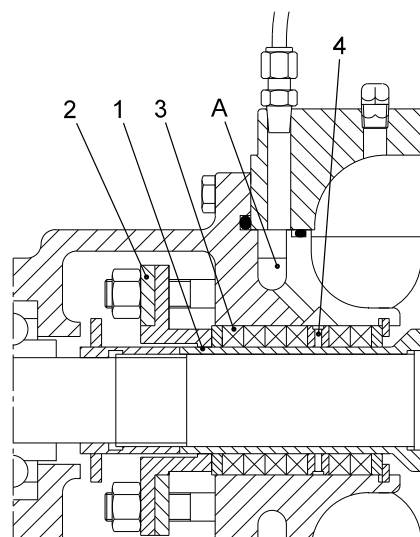

TM04 1849 1108

Fig. 19 Sectional view of a stuffing box with internal flushing liquid

Pos.	Description
1	Shaft sleeve
2	Gland
3	Packing ring
4	Distribution ring
A	Drilled hole for flushing liquid (pumped liquid)

Base frame

Pump and motor are mounted on a common base frame designed according to Hydraulic Institute standard, ANSI/HI 1.3-2000.



G1A703

Fig. 20 HS pump with motor and base frame

Surface treatment

Prior to delivery to the customer, pump, motor and base frame are top coated with a black semi gloss RAL9005 coating; coating thickness is 25 μm .

Standard units are not painted internally.

Test pressure

Pressure testing is made with water at +20 °C containing corrosion inhibitor.

The standard hydrostatic test pressure is 1.5 times pressure against "closed valve" or "shut off" pressure. However, this may vary from one HS pump to another. See table below.

Rated pressure	Operating pressure		Test pressure	
	bar	MPa	bar	MPa
PN 10	10	1.0	15	1.5
PN 16	16	1.6	24	2.4

Ambient temperature and altitude

The ambient temperature and the installation altitude are important factors for the motor life, as they affect the life of the bearings and the insulation system.

Ambient temperature must not exceed + 40 °C.

If the ambient temperature exceeds + 40 °C or if the motor is installed more than 1000 m above sea level, the motor must not be fully loaded due to the low density and consequently low cooling effect of the air. In such cases, it may be necessary to use a motor with a higher output.

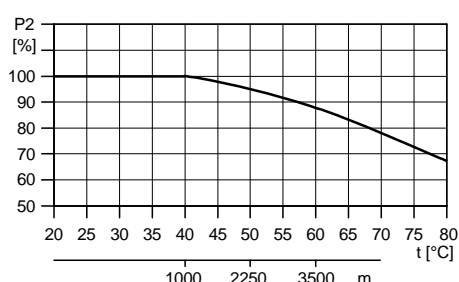

Fig. 21 Relationship between motor output (P2) and ambient temperature

Example

Fig. 21 shows that the load of the motor must be reduced to 88 % when installed 3500 m above sea level.

At an ambient temperature of 70 °C, the load of the motor must be reduced to 78 % of the rated output.

Liquid temperatures

The maximum liquid temperature marked on the pump nameplate depends on the mechanical shaft seal used:

- Temperature range for NBR 0 °C up to +100 °C
- Temperature range for FKM +15 °C up to +100 °C.

Shaft seal

The materials of the shaft seal types used in HS pumps have certain characteristics. These characteristics may be of importance when choosing the shaft seal for the pump.

Carbon/aluminium oxide (xBVx)

Good all-round seal for not too demanding applications. The seal has the following features:

- Brittle material requiring careful handling.
- Worn by liquids containing solid particles.
- Limited corrosion resistance, $5 < \text{pH} < 9$, depending on ceramic type.
- Relatively good dry-running properties. However, thermal cracks may occur in case of a sudden influx of water to a hot seal after a period of dry running or similar condition.
- The carbon of the seal offers properties very similar to the carbon/tungsten carbide seal. However, compared to the carbon/tungsten carbide seal, the pressure and temperature ranges are limited.

Carbon/silicon carbide (xBQx)

Seals with one carbon seal face have the following features:

- Brittle material requiring careful handling
- Worn by liquids containing solid particles
- Good corrosion resistance
- Can withstand temporary dry running.
- The self-lubricating properties of carbon make the seal suitable for use even with poor lubricating conditions (high temperatures) without generating noise. However, such conditions will cause wear of the carbon seal face leading to reduced seal life.

NBR (xxxP)

NBR (nitrile) rubber covers a wide range of liquids at temperatures below +100 °C.

- Good mechanical properties.

FKM (xxxV)

FKM rubber covers a very wide range of liquids and temperatures.

- Poor mechanical properties at low temperatures
- Resistant to water up to +100 °C
- Resistant to mineral oils and vegetable oils
- Not resistant to alkaline liquids at high temperatures.

Pressure

Maximum pressure

- Pump made of ductile iron: 16 bar
- Pump made of cast iron: 10 bar.

Maximum inlet pressure

Inlet pressure + pump pressure must always be lower than maximum pressure of the pump.

Minimum inlet pressure

The minimum inlet pressure must correspond to the NPSH curve for the pump + a safety margin of minimum 0.5 metres head. NPSH appears from the performance curves starting on page 40.

Flow

Minimum flow rate

The pump must not run against a closed discharge valve as this will cause an increase in temperature/formation of steam in the pump. This may cause shaft damage, impeller erosion, short life of bearings, stuffing boxes with packing rings or mechanical seals due to stress or vibration.

The minimum flow rate must be at least 10 % of the maximum flow rate stated on the pump nameplate.

Maximum flow rate

The maximum flow rate must not exceed the value stated on the nameplate. If the maximum flow rate is exceeded, cavitation and overload may occur.

Maximum particle size

The table shows the permissible size of particles.

Pump type	Maximum particle size (non-abrasive particles) [mm]
HS65-50-242	4.8
HS65-50-331	4.1
HS100-80-242	7.9
HS100-80-356	7.9
HS125-100-280	9.7
HS125-100-305	19.1
HS125-100-381	6.4
HS150-125-305	16.0
HS150-125-381	19.1
HS200-150-305A	25.4
HS200-150-305C	25.4
HS200-150-381	20.6
HS200-150-483	19.1
HS200-150-508	19.1
HS250-200-305	22.4
HS250-200-381	25.4
HS300-200-489	26.2
HS300-250-305	25.4
HS300-250-381	31.8
HS350-250-498	30.5
HS350-250-630	29.7
HS350-300-508	47.5
HS400-350-397	47.5

Reference

Please read this section on installation of HS pumps as a rough overview of the installation requirements to be fulfilled.

For full details on foundation, mechanical installation, alignment, piping, electrical installation, etc. please refer to the **Installation and operating instructions** for the HS pumps. Installation and operating instructions can be downloaded from Grundfos' homepage, www.grundfos.com, or you may contact your local Grundfos company.

Mechanical installation

General installation guidelines

General installation guidelines are for two installation types:

- installation at ground level
- installation in high-rise buildings.

The installation procedure is basically the same for the two installation types. The attached equipment, such as foundation, valves, expansion joints and lengths and types of pipe are the same. Whether a vibration damper is to be fitted in ground level applications (or not) depends merely on the application. For high-rise applications, a vibration damper must always be fitted.

Installation at ground level

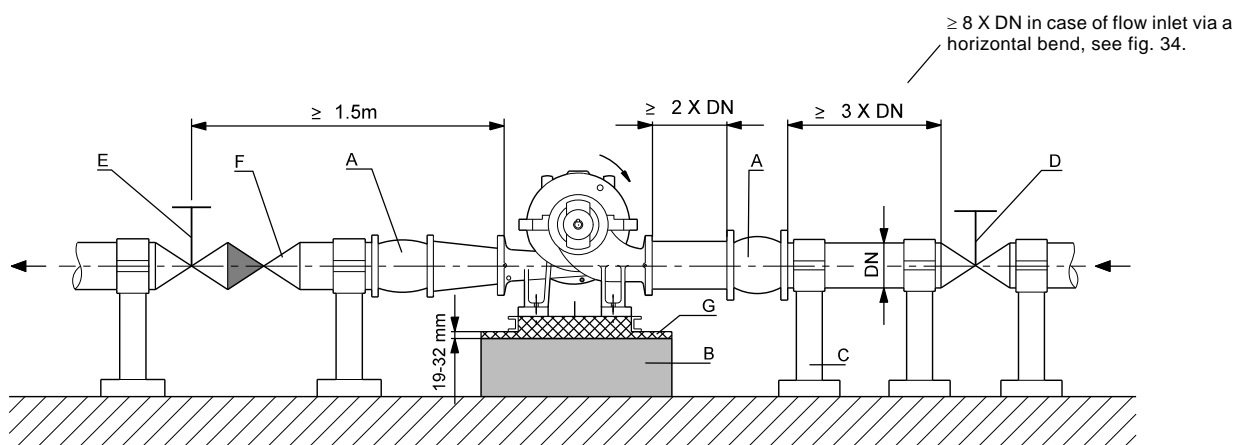

Fig. 22 Installation guidelines for a pump installed at ground level

Installation in high-rise buildings

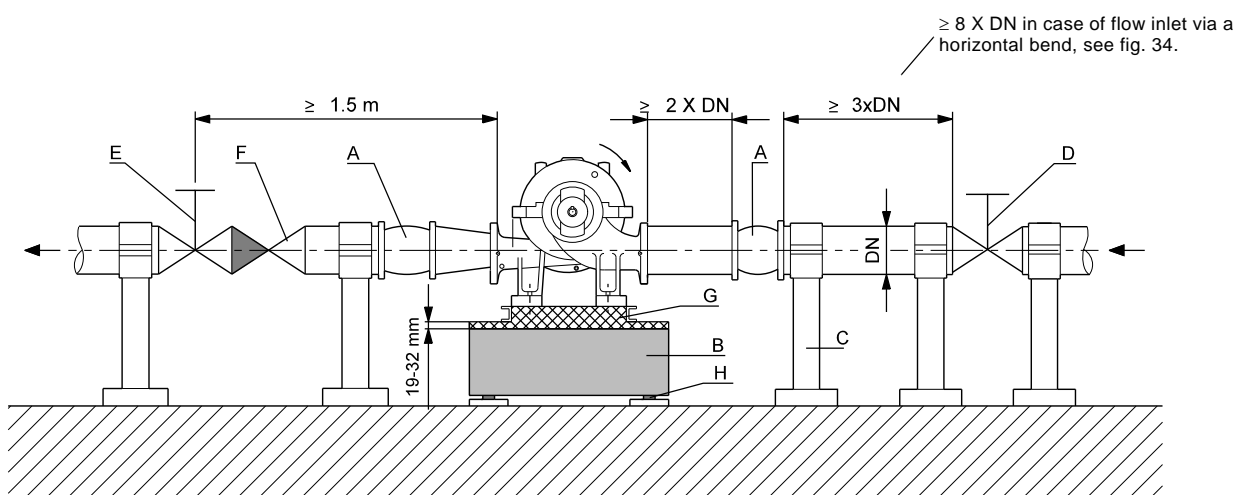

Fig. 23 Installation guidelines for a pump installed in high-rise buildings

TM03 9910 2208

TM03 9911 2208

- A: Expansion joint.
- B: Foundation (the weight should be 3-5 times that of the complete pump unit).
- C: Rigid pipe holders and anchorage.
- D: Isolating valve (full-flow type).
- E: Discharge isolating/trottle valve.
- F: Non-return valve/check valve.
- G: Grout on top of foundation. The base frame must be filled with grout to top level, see fig. 25.
- H: Vibration damper.

Vibration dampers

A specific application may call for vibration dampeners to prevent pump vibrations from being transmitted to the building or the pipework. In order to select the right vibration damper, you need this information:

- Forces transferred through the damper.
- Motor speed. In the case of speed control, this must also be taken into account.
- Desired dampening in % (recommended value: 70 %).

The selection of vibration damper differs from installation to installation. In certain cases a wrong damper may increase the vibration level. Vibration dampers should therefore be sized by the supplier of the vibration dampers.

Expansion joints

Expansion joints provide these advantages:

- Absorption of thermal expansion and contraction of pipework caused by variations in liquid temperature.
- Reduction of mechanical influences in connection with pressure surges in the pipework.
- Isolation of structure-borne noise in the pipework (only rubber bellows expansion joints).

Note: Do not fit expansion joints to make up for inaccuracy in the pipework, for instance centre displacement or misalignment of flanges.

The expansion joints should be fitted at a minimum distance of 2 pipe diameters (DN) away from the pump flange on the suction side. This prevents turbulence in the joints, thus ensuring optimum suction conditions and minimum pressure drop on the discharge side.

At flow velocities > 2.4 m/s, we recommend you to fit larger expansion joints matching the pipework.

Location

Install the pump as close as possible to the supply of pumped liquid and with the shortest and most direct suction pipe practical.

Install the pump with sufficient accessibility for inspection and maintenance. Allow ample space and headroom for the use of an overhead crane or hoist sufficiently strong to lift the unit.

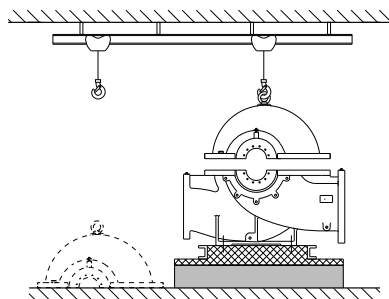

TM04 0382 0608

Fig. 24 HS pump with accessibility for inspection and headroom for the use of an overhead crane

Foundation

We recommend that you install the pump on a concrete foundation which is heavy enough to provide permanent and rigid support for the entire pump. The foundation must be capable of absorbing any vibration, normal strain or shock. As a rule of thumb, the weight of the concrete foundation should be 3-5 times the weight of the complete pump unit.

In installations where silent operation is particularly important, we recommend a foundation with a mass up to 5 times that of the complete pump unit.

Grouting

NOTE: Unless otherwise specified, the base frame must be completely filled with grout and the levelling wedges grouted in place. The product warranty is void if this instruction is not followed.

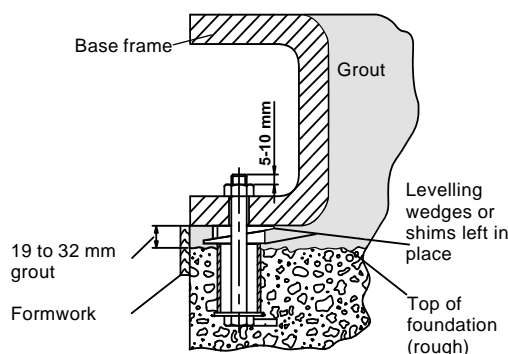

TM04 0384 0608

Fig. 25 Sectional view of foundation with foundation bolt, grouting and base frame

Grouting compensates for uneven foundation, distributes weight of unit, dampens vibrations and prevents shifting. Use an approved, non-shrinking grout. If you have questions or doubts about the grouting, please contact an expert on grouting.

Measuring instruments

To ensure continuous monitoring of operation, we recommend you to install pressure gauges on pump suction and discharge flanges. The pressure gauge on the suction side must be capable of measuring vacuum. The pressure gauge tapings should only be opened for test purposes. The measuring range of the discharge side pressure gauge should be 20 % above the maximum pump discharge pressure.

When measuring with pressure gauges on the pump flanges, please note that a pressure gauge does not register dynamic pressure (velocity pressure). On HS pumps, the diameters of the suction and discharge flanges are different which results in different flow velocities in the two flanges. Consequently, the pressure gauge on the discharge flange will not show the pressure stated in the technical documentation, but a value which may be lower.

Piping

Suction and discharge pipe

In order to minimise friction losses and hydraulic noise in the piping, choose piping that is one or two sizes larger than the pump suction and discharge ports. Typically, flow velocities should not exceed 2 m/s (6 ft/sec) for the suction pipe (port) and 3 m/s (9 ft/sec) for the discharge pipe (port).

Make sure that the NPSH available (NPSHA) is higher than the NPSH required (NPSHR). $NPSH = \text{Net Positive Suction Head}$.

General precautions

When installing the piping, observe these precautions:

- Always run the piping direct to the pump.
Note: Make sure that both suction and discharge piping are independently supported near the pump so that no strain is transmitted to the pump when the flange bolts are tightened. Use pipe hangers or other supports with necessary spacing to provide support.
- When expansion joints are used in the piping system, fit the joints at a minimum distance of 2 pipe diameters away from the pump on the suction side. This prevents turbulence in the joints, thus ensuring optimum suction conditions.
- Install piping as straight as possible and avoid unnecessary bends. Where necessary, use 45 ° or long sweep 90 ° fittings to reduce friction loss.
- Where flanged joints are used, ensure that inside diameters match properly.
- Provide for expansion of pipe material by means of expansion joints on both sides of the pump.
- Always allow sufficient space/accessibility for maintenance and inspection.

Suction piping

Note: The sizing and installation of the suction piping is extremely important.

Locate the pump below system level whenever possible. This will facilitate priming, assure a steady liquid flow and provide a positive suction head.

Many NPSH problems can be avoided if the suction piping is properly installed.

System types

These pumps can be installed in two types of system:

1. Closed systems or open systems where the liquid level is above the pump inlet (flooded systems), meaning that a positive¹⁾ inlet pressure will be available.
2. Open systems where the liquid level is below the pump inlet (suction lift), meaning that a negative¹⁾ inlet pressure will be available.

1) Positive or negative inlet pressure in relation to ambient atmospheric pressure.

General suction piping guidelines

Avoid air pockets or turbulence in the suction pipe. Never use reducers in a horizontal suction pipe as shown in fig. 27. Instead, use an eccentric reducer as illustrated in fig. 26.

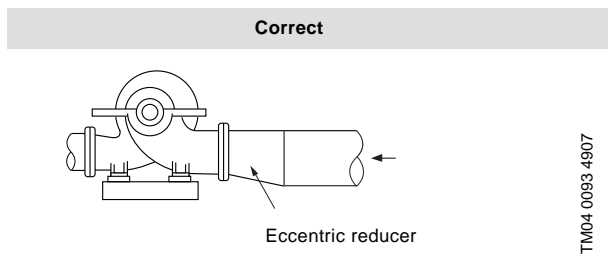

TM04 0093 4907

Fig. 26 Correctly mounted reducer

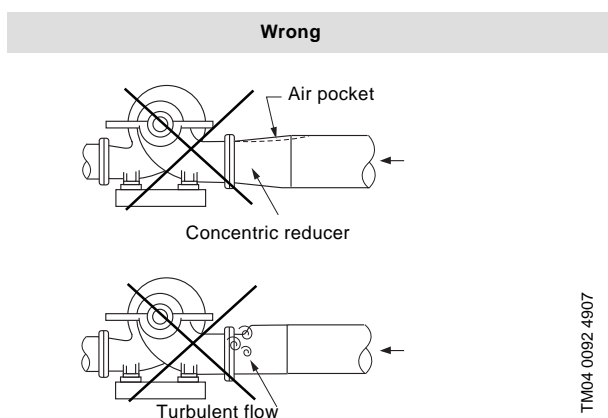

TM04 0092 4907

Fig. 27 Reducers resulting in air pockets and turbulence

Flooded systems

(Closed systems and open systems where the liquid level is above the pump inlet).

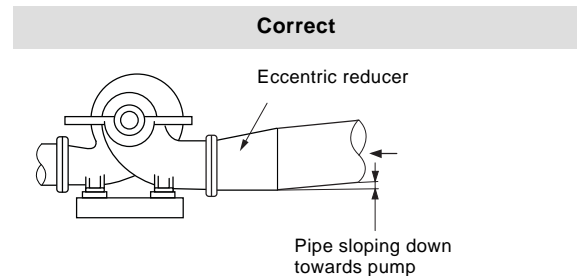

TM04 0148 4907

Fig. 28 Correctly mounted suction piping

Suction lift systems

(Closed systems and open systems where the liquid level is below the pump inlet).

Install the suction pipe sloping upwards towards the suction port. Any high point in the pipe will be filled with air and thus prevent proper operation of the pump. When reducing the piping to the suction port diameter, use an eccentric reducer with the eccentric side down to avoid air pockets

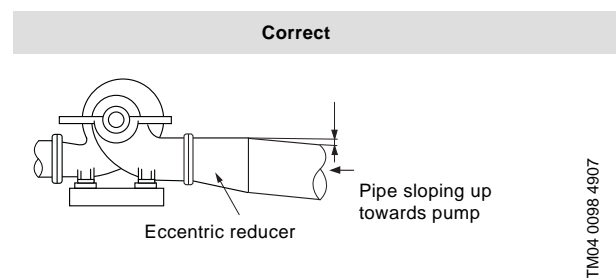

TM04 0098 4907

Fig. 29 Correctly mounted suction piping

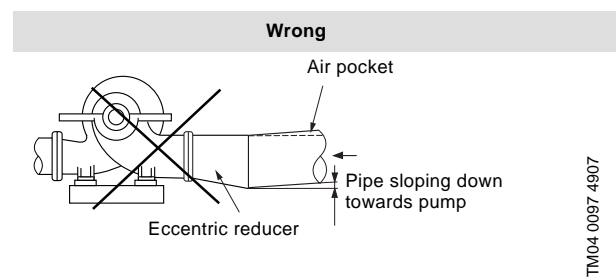

TM04 0097 4907

Fig. 30 Suction piping resulting in air pockets

Suction piping if the feed line comes in different horizontal planes

Avoid high spots, such as loops, as they will collect air and throttle the system or lead to uneven pumping.

Correct

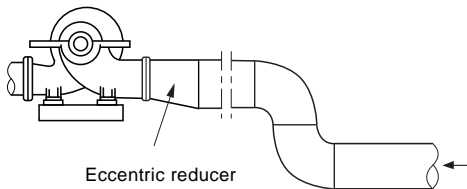

Fig. 31 Correctly mounted suction piping

TM04 0095 4907

Wrong

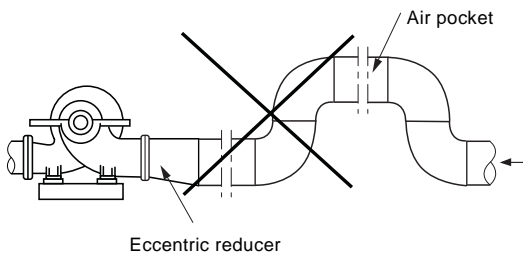

Fig. 32 Suction piping resulting in air pockets

TM04 0094 4907

Installations with vertical suction piping in confined space

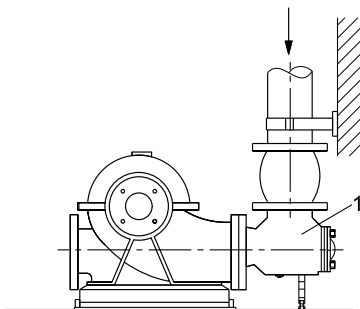

Fig. 33 Suction diffuser (1) in the suction piping

TM04 0096 4907

Suction piping with a horizontal elbow in the feed line

Make sure that the liquid flow is evenly distributed to both sides of the double-suction impellers. There is always an uneven, turbulent flow through an elbow, see below. If an elbow is installed in the suction pipe near the pump in a position other than vertical, more liquid will enter one side of the impeller than the other. This will result in heavy, unbalanced thrust loads overheating the bearings, causing rapid wear and reducing the hydraulic performance.

Correct

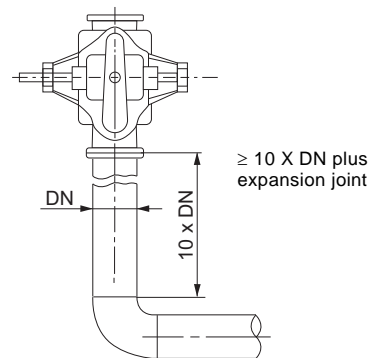

Fig. 34 Recommended suction pipe installation with a length of straight pipe between horizontal elbow and pump.

TM04 0150 4907

Wrong

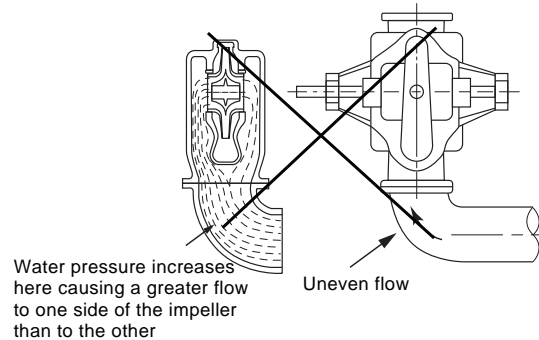

Fig. 35 Unbalanced loading of a double-suction impeller due to uneven flow through a horizontal elbow close to the pump.

TM04 0149 4907

Valves in suction piping

If the pump is operating under static suction lift conditions, install a non-return valve in the suction pipe to avoid having to prime the pump each time it is started. The non-return valve should be of the flap type or a foot-valve with a minimum of pressure loss.

Discharge piping

The discharge pipe is usually preceded by a non-return valve and a discharge isolating/throttle valve. The non-return valve protects the pump against excessive back pressure and reverse rotation of the pump and prevents back flow through the pump in case of operational stop or failure of the motor.

In order to minimise friction losses and hydraulic noise in the pipework, flow velocities should not exceed 3 m/s (9 ft/sec) in the discharge pipe (port).

On long horizontal runs, it is desirable to keep the piping as level as possible.

Avoid high spots, such as loops as they will collect air and throttle the system or lead to uneven pumping.

Auxiliary piping

1. Drains

Install drain pipes from pump casing and stuffing boxes to a convenient disposal point.

2. Pumps fitted with stuffing boxes

When suction pressure is below ambient pressure, supply the stuffing boxes with liquid to provide lubrication and prevent the ingress of air. This is normally achieved via a flushing pipe from the pump discharge side to the stuffing box. A control valve or orifice plate may be fitted in the flushing pipe to control the pressure to the packing gland/stuffing box.

If the pumped liquid is dirty and cannot be used for flushing the seals, we recommend a separate clean, compatible liquid supply to the stuffing box at 1 bar (15 psi) above the suction pressure.

3. Pumps fitted with mechanical seals

Seals requiring re-circulation will normally be provided with a flushing pipe from the pump casing.

Note: When pumping hot liquids, we recommend that the supply of any external flushing or cooling liquid is continued after stopping the pump. This should be done to avoid seal damage.

Pump size

Selection of pump size should be based on these data:

- required flow and pressure
- pressure loss as a result of height differences (geometric lifting height)
- friction loss in the pipework (pipes, bends, valves, etc.)
- best efficiency at the estimated duty point.

Efficiency

If you expect the pump to always operate in the same duty point, select a pump which is operating in a duty point corresponding to the best efficiency of the pump.

In case of varying consumption, select a pump whose best efficiency falls within the duty range covering the greater part of the duty time.

Material

The material variant should be selected on the basis of the liquid to be pumped.

Motor size

The selection of motor size should be based on these parameters:

- **flow rate margin, the maximum required flow rate in your application**
- **motor safety margin.**

A selection has to be made for both parameters.

Parameter 1 - flow rate margin in your application

Understanding the operating conditions under which your pump will run is important to ensure long life and trouble-free operation of both the pump and motor. The more specific these parameters are understood, the more refined and specific your motor selection can be.

If you intend to run the pump in one specific duty point, the power absorbed in this point (P2) could in theory be your motor's rated power. However, because of the uncertainties in system calculations or the addition of duty conditions around the primary duty point, it is recommended to have a safety margin for P2 power.

To accomplish this, we recommend the following method for motor selection.

a) Select one of the following flow rate margins for your pump:

- Duty point to the end of the actual curve (default in CAPS).
- Duty point +30 %
- Duty point +20 %
- Duty point +10 %.

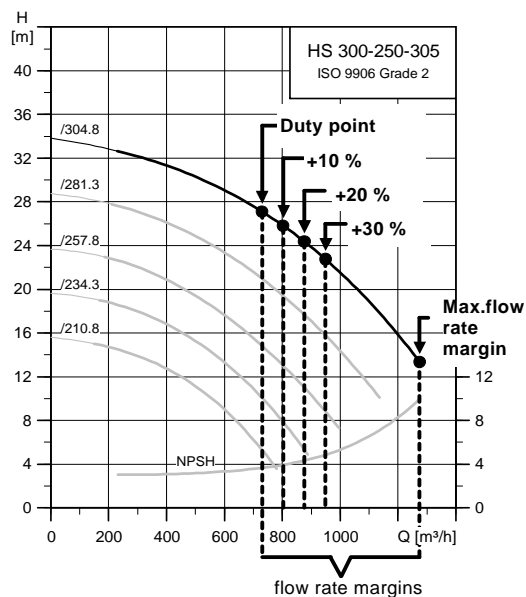

Fig. 36 Selection of a flow rate margin on basis of conditions around the primary duty point and uncertainties in system calculations

b) Establish P2 for the selected flow rate margin.

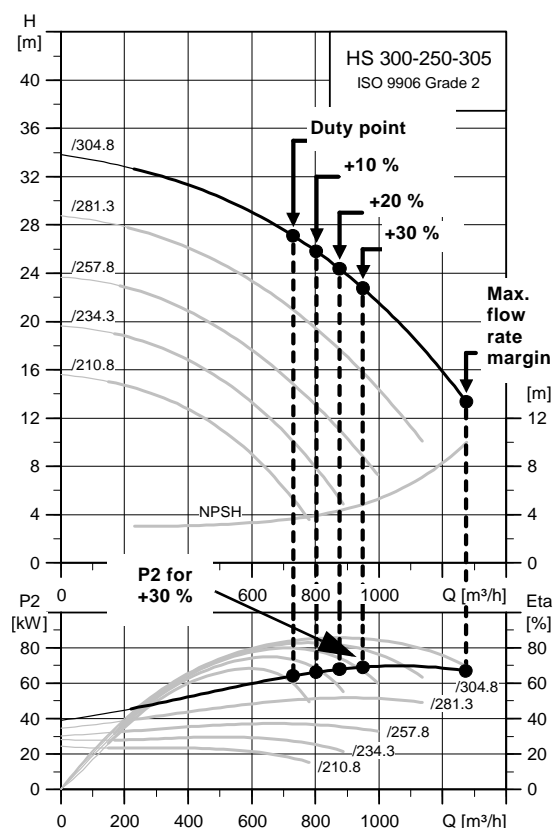

Fig. 37 Establishing P2 for a selected flow rate margin of 30 %

TM04 0454 0608

TM04 0349 0608

In some cases, however, the input power actually decreases as the flow rate increases. It will thus be found at some other point within this flow range. This is typically the case when the impeller is trimmed to the smallest diameter.

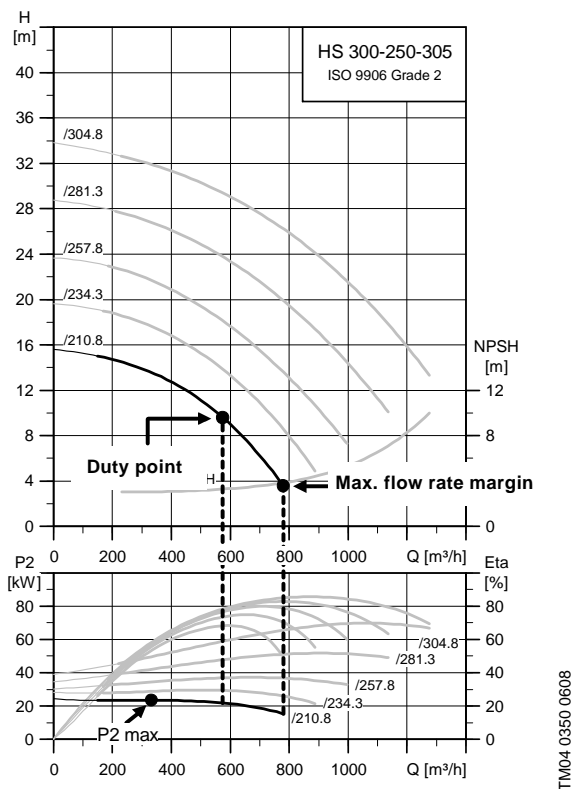

Fig. 38 Establishing the maximum P2 when P2 decreases as the flow rate increases.

Parameter 2 - motor safety margin

As with any system, uncertainties and tolerances exist, the motor safety margin takes the following into account:

- The actual head is at the high end of the tolerance described in ISO 9906. This will increase the required P2.
- Pump efficiency is at the low end of the tolerance described in ISO 9906. This will increase the required P2.
- Motor efficiency is at the low end.

To establish the motor safety margin, select method 1 or alternatively method 2:

Method 1)

Add a safety margin as outlined in ISO 5199 to the maximum P2 found when determining parameter 1.

(Grundfos recommends the addition of a safety margin in accordance with this standard; default in WebCAPS.)

Required pump power up to [kW]	Motor power P2 [kW]
540	600
473	525
405	450
360	400
338	375
320	355
302	335
284	315
225	250
180	200
144	160
119	132
99	110
81	90
68	75
49	55
40	45
32.5	37
26	30
19	22
15.9	18.5
12.8	15
9.1	11
6.1	7.5
4.3	5.5
3.2	4
2.3	3
1.7	2.2
1.1	1.5

Fig. 39 Safety margins according to ISO 5199

Method 2)

Add a 5 % safety margin to the maximum P2 found when determining parameter 1.

Note: If a safety margin of 5 % is selected, normal guarantees of the performance from Grundfos may not apply.

If not specified by the customer, the motor size will be determined in accordance with the WebCAPS defaults listed above. This means a motor which covers the full performance range and with a motor safety margin according to ISO 5199.

Where to find the information

See performance curves page 40 to page 110.

Pumped liquids

We recommend HS pumps for thin, clean and non-aggressive, non-explosive liquids, not containing solid particles or fibres. The liquid must not attack the pump materials chemically or mechanically.

The mechanical shaft seal must be suitable for the liquid.

The maximum liquid temperature range depends on the mechanical shaft seal used:

Nitrile rubber (xxxP): 0 °C to +100 °C

FKM (xxxV): +15 °C to +100 °C.

Water in heating and ventilating systems often contains additives to prevent negative effects such as system corrosion or calcareous deposits. If you want to use the pump for such liquids and if the temperature is above 80 °C, use special shaft seals to avoid crystallization/precipitation between the seal faces.

Liquid density and viscosity

If you pump liquids with a density and/or viscosity higher than that of water, use motors with correspondingly higher outputs.

The effect of high density on centrifugal pump performance

A high-density liquid only affects the power consumption of a centrifugal pump:

- The head, flow rate and pump efficiency will remain unchanged.
- The power consumption will increase at a ratio corresponding to the increase in density. A liquid with a specific gravity of 1.2 will thus require a 20 % larger power input.
- An oversize motor will often be required.

WebCAPS can help you select the right pump for liquids with a density different from that of water.

The effect of high viscosity on centrifugal pump performance

A high-viscosity liquid affects a centrifugal pump in several ways:

- The power consumption will be increased, i. e. a larger motor is required.
- Head, flow rate and pump efficiency will be reduced.

WebCAPS can help you select the right pump for liquids with a viscosity different from that of water.

The standard motor brand used for the entire HS pump range is Grundfos type MMG-G EFF1 motors. Other makes and voltage variants are available on request.

2-pole motors

Motor P ₂ [kW]	Frame size	Standard voltage [V]	I _{1/1} [A]	Cos φ _{1/1}	η [%]	I _{start} /I _{1/1} [%]
18.5	MMG-G 160L	380-480 D/660-690 Y	33.5-26.5/19.2-18.4	0.92-0.90	91.4-93.2	840
22	MMG-G 180MA	380-480 D/660-690 Y	40.0-34.0/23.0-24.0	0.90-0.83	92.6-93.5	860
30	MMG-G 200LA	380-480 D/660-690 Y	56.0-44.5/32.5-31.0	0.88-0.86	92.2-93.6	860
37	MMG-G 200LA	380-480 D/660-690 Y	67.0-52.5/38.5-36.5	0.89	93.8-95	860
45	MMG-G 225MA	380-480 D/660-690 Y	78.5-63.0/45.0-44.0	0.94-0.91	93.3-94.3	840
55	MMG-G 250SA	380-480 D/660-690 Y	95.5-76.5/55.0-53.0	0.93-0.92	94.0	740
75	MMG-G 250MA	380-480 D/660-690 Y	128-102/73.5-71.5	0.94-0.93	94.6	750
90	MMG-G 280SA	380-480 D/660-690 Y	154-124/88.0-85.5	0.94-0.93	95.0	700
110	MMG-G 280MA	380-480 D/660-690 Y	190-150/108-104	0.93	95.5	760

4-pole motors

Motor P ₂ [kW]	Frame size	Standard voltage [V]	I _{1/1} [A]	Cos φ _{1/1}	η [%]	I _{start} /I _{1/1} [%]
2.2	MMG-G 100L	220-277 D/380-480 Y	7.80-6.30/4.50-3.65	0.85-0.83	87.2-87.9	760-960
3	MMG-G 100L	380-480 D/660-690 Y	6.25-5.05/3.60-3.50	0.83-0.81	87.7-88.4	980
3.7	MMG-G 112M	380-480 D/660-690 Y	7.45-6.00/4.30-4.15	0.85-0.83	89.2-89.9	980
4	MMG-G 112M	380-480 D/660-690 Y	8.05-6.45/4.60-4.50	0.85-0.83	89.2-89.9	980
5.5	MMG-G 132S	380-480 D/660-690 Y	10.8-8.50/6.20-5.95	0.86-0.85	90.6-91.5	980
7.5	MMG-G 132M	380-480 D/660-690 Y	14.4-11.6/8.35-8.10	0.87-0.85	90.7-91.5	870
11	MMG-G 160M	380-480 D/660-690 Y	20.6-16.4/11.6-11.4	0.89-0.87	92.7-93.5	870
15	MMG-G 160L	380-480 D/660-690 Y	27.0-22.0/15.6-15.2	0.90-0.88	93.2-94.0	860
18.5	MMG-G 180MC	380-480 D/660-690 Y	34.5-28.0/19.8-19.4	0.87-0.85	93.7-94.5	880
22	MMG-G 180LC	380-480 D/660-690 Y	41.0-33.0/23.6-23.0	0.87-0.85	93.7-94.5	830
30	MMG-G 200LC	380-480 D/660-690 Y	54.0-43.5/31.0-30.5	0.89-0.87	94.2-95.0	930
37	MMG-G 225SC	380-480 D/660-690 Y	68.5-55.0/39.5-38.5	0.87-0.85	94.7-95.5	780
45	MMG-G 225MC	380-480 D/660-690 Y	82.5-66.5/47.5-46.5	0.87-0.85	94.7-95.5	740
55	MMG-G 250SC	380-480 D/660-690 Y	104-80.0/60.0-55.5	0.85-0.86	94.9-96.0	740
75	MMG-G 250MC	380-480 D/660-690 Y	142-110/81.5-76.0	0.85-0.86	94.7-96.0	730
90	MMG-G 280SB	380-480 D/660-690 Y	170-130/97.5-91.0	0.85-0.86	95.0-96.0	700
110	MMG-G 280MB	380-480 D/660-690 Y	206-160/120-112	0.85-0.86	95.5-96.0	680
132	MMG-G 315SB	380-480 D/660-690 Y	250-190/142-132	0.85-0.87	95.1-96.0	600
160	MMG-G 315MB	380-480 D/660-690 Y	300-230/172-160	0.86-0.87	95.1-96.0	600
200	MMG-G 315MB	380-480 D/660-690 Y	365-290/210-166	0.88	95.8	780
250	MMG-G 315CB	380-480 D/660-690 Y	455-355/260-246	0.89	94.5-95.2	550-830
315	MMG-G 315DB	380-480 D/660-690 Y	575-445/330-310	0.88-0.90	94.5-95.2	550-830
335	MMG-G 315DB	380-480 D/660-690 Y	610-470/350-330	0.88-0.90	94.5-95.3	550-830
355	MMG-G 355AB	380-480 D/660-690 Y	645-510/370-355	0.89-0.88	94.5-95.2	550-830
375	MMG-G 355AB	380-480 D/660-690 Y	680-540/390-375	0.89-0.88	94.5-95.3	550-830
400	MMG-G 355CB	380-480 D/660-690 Y	730-570/420-395	0.88-0.89	94.7-95.3	550-830
450	MMG-G 355CB	380-480 D/660-690 Y	820-640/470-445	0.88-0.89	94.7-95.5	550-830
500	MMG-G 400AB	380-480 D/660-690 Y	890-700/515-485	0.90	94.7-95.5	550-830
525	MMG-G 400AB	380-480 D/660-690 Y	935-735/540-510	0.90	94.7-95.6	550-830
560	MMG-G 400CB	380-480 D/660-690 Y	995-785/575-545	0.90	94.8-95.6	550-830
600	MMG-G 400CB	380-480 D/660-690 Y	1060-840/615-585	0.90	94.8-95.7	550-830

6-pole motors

Motor P ₂ [kW]	Frame size	Standard voltage [V]	I _{1/1} [A]	Cos φ _{1/1}	η [%]	I _{start} /I _{1/1} [%]
15.0	MMG-G 180LC	380-480 D/660-690 Y	29.5-24.0/17.0-16.8	0.85-0.81	91.6-93.1	520-830
18.5	MMG-G 200LC	380-480 D/660-690 Y	37.0-30.5/21.6-21.0	0.82-0.78	92.2-93.5	460-760
22.0	MMG-G 200LC	380-480 D/660-690 Y	43.5-35.5/25.0-24.5	0.83-0.80	92.3-93.8	460-770
30	MMG-G 225MC	380-480 D/660-690 Y	56.0-46.5/32.5-32.0	0.87-0.83	93.5-94.2	460-730
37	MMG-G 250SC	380-480 D/660-690 Y	68.0-56.5/39.0-39.5	0.88-0.83	94.0-94.8	540-870
45	MMG-G 250MC	380-480 D/660-690 Y	82.5-67.5/47.5-47.0	0.88-0.84	94.1-94.9	540-880
55	MMG-G 280SB	380-480 D/660-690 Y	99.5-78.5/57.0-54.5	0.89	95.0	530-830
75	MMG-G 280MB	380-480 D/660-690 Y	136-108/78.0-74.5	0.89	95.0	600-850
90	MMG-G 315SB	380-480 D/660-690 Y	160-126/92.5-88.5	0.90	95.2	600-830
110	MMG-G 315MB	380-480 D/660-690 Y	196-156/114-108	0.89	95.2	510-820
132	MMG-G 315MB	380-480 D/660-690 Y	236-184/134-128	0.90	95.2	550-800
160	MMG-G 315CB	380-480 D/660-690 Y	300-232/174-166	0.86-0.87	94.5-95.5	520-800
200	MMG-G 315CB	380-480 D/660-690 Y	375-290/216-208	0.86-0.87	94.5-95.6	520-800
220	MMG-G 315CB	380-480D/660-690Y	405-320/234-186	0.86-0.87	94.5-95.6	520-800
250	MMG-G 315DB	380-480D/660-690Y	455-360/260-208	0.86-0.87	94.5-95.6	520-800
300	MMG-G 355AB	380-480 D/660-690 Y	565-430/325-310	0.86-0.87	94.5-96.0	550-840
315	MMG-G 355CB	380-480 D/660-690 Y	580-455/335-320	0.87	95.0-96.0	550-840
335	MMG-G 355CB	380-480 D/660-690 Y	620-480/355-340	0.87	95.0-96.0	550-840
355	MMG-G 400AB	380-480 D/660-690 Y	650-505/375-355	0.88	95.0-96.0	540-830
375	MMG-G 400AB	380-480 D/660-690 Y	685-535/395-375	0.88	95.0-96.0	540-830
450	MMG-G 400AB	380-480 D/660-690 Y	820-640/470-450	0.88	95.4-96.2	540-830

The following many pages are divided into sections:

pages 38 and 39 A brief explanation of how to read the curve charts, the curve conditions, etc.

Performance curves and technical data:

page 40 2-pole pumps

page 48 4-pole pumps

page 92 6-pole pumps

How to read the curve charts

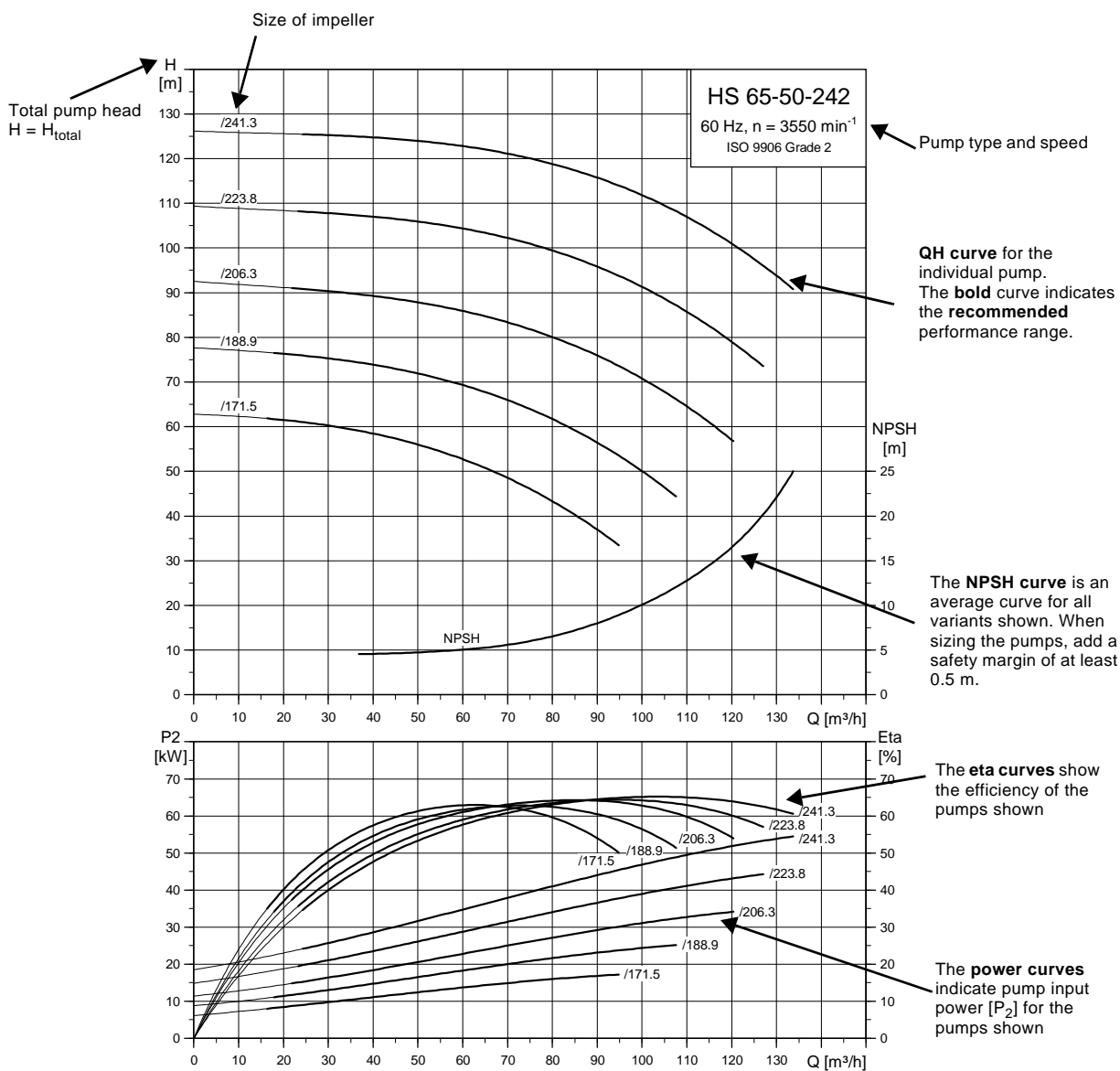

TM03 9844 4507

Curve conditions

The guidelines below apply to the curves shown in the performance charts on page 40 to page 110.

- Tolerances according to: ISO 9906, Grade 2.
- The curves show pump performance with different impeller diameters at the nominal speed.
- The **bold** part of the curves show the **recommended** operating range.
- Do not operate the pump along the thin parts of the curves. If your duty point lies here, you should select a smaller or larger pump type.
- Do not use the pumps at minimum flows below $0.1 \times Q_{\max}$ stated on the pump name plate because of the risk of overheating of the pump.
- The curves apply to the pumping of airless water at a temperature of +20 °C and a kinematic viscosity of $1 \text{ mm}^2/\text{s}$ (1 cSt).
- **ETA:** The lines show values of the hydraulic efficiency of the pump for the different impeller diameters.
- **NPSH:** The curves show average values measured under the same conditions as the performance curves.
When sizing the pump, add a safety margin of at least 0.5 m.
- In case of other densities than 1000 kg/m^3 the discharge pressure is proportional to the density.
- When pumping liquids with a density higher than 1000 kg/m^3 , motors with correspondingly higher outputs must be used.

Calculation of total head

The total pump head consists of the height difference between the measuring points + the differential head + the dynamic head.

$$H_{\text{total}} = H_{\text{geo}} + H_{\text{stat}} + H_{\text{dyn}}$$

H_{geo} :	Height difference between measuring points.
H_{stat} :	Differential head between suction and the discharge side of the pump.
H_{dyn} :	Calculated values based on the velocity of the pumped liquid on the suction and the discharge side of the pump.

Performance tests

The requested duty point for every pump is tested according to ISO 9906, Grade 2, and without certification.

In case of pumps ordered on the basis of impeller diameter only (no requested duty point), the pump will be tested at a duty point which is 2/3 of the maximum flow of the published performance curve which is related to the ordered impeller diameter (according to ISO 9906, Grade 2).

The primary duty point is guaranteed by a certified performance test. Additional point(s), on request, are offered for reference only. Testing certificate has to be ordered separately.

Certificates

Certificates have to be confirmed for every order and are available on request as follows:

- Certificate of compliance with the order (EN 10204-2.1)
- Pump test sheet.

Witness test

When the pumps are being tested or are tested with a certification it is possible for the customer to witness the testing procedure according to ISO 9906.

The witness test is not a certificate and will not result in a written statement from Grundfos. The witness itself is the only guarantee that everything is carried out as prescribed in the testing procedure.

If the customer wants to witness test the pump performance, place this request on the order.

Performance curves Technical data

HS 65-50-242
2-pole

2-pole

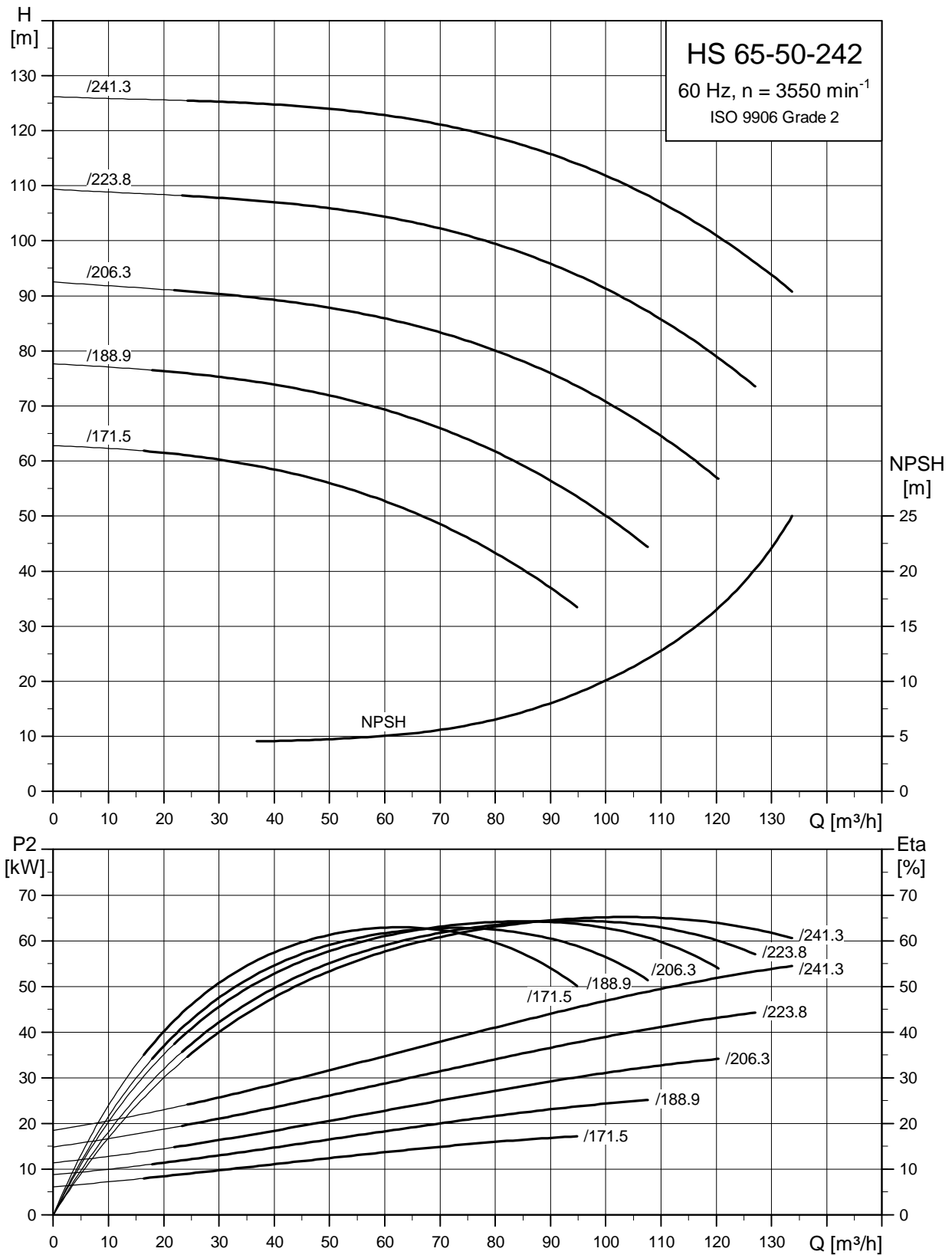

TM03 9844 4507

Dimensional sketches

HS standard, 65-50-242

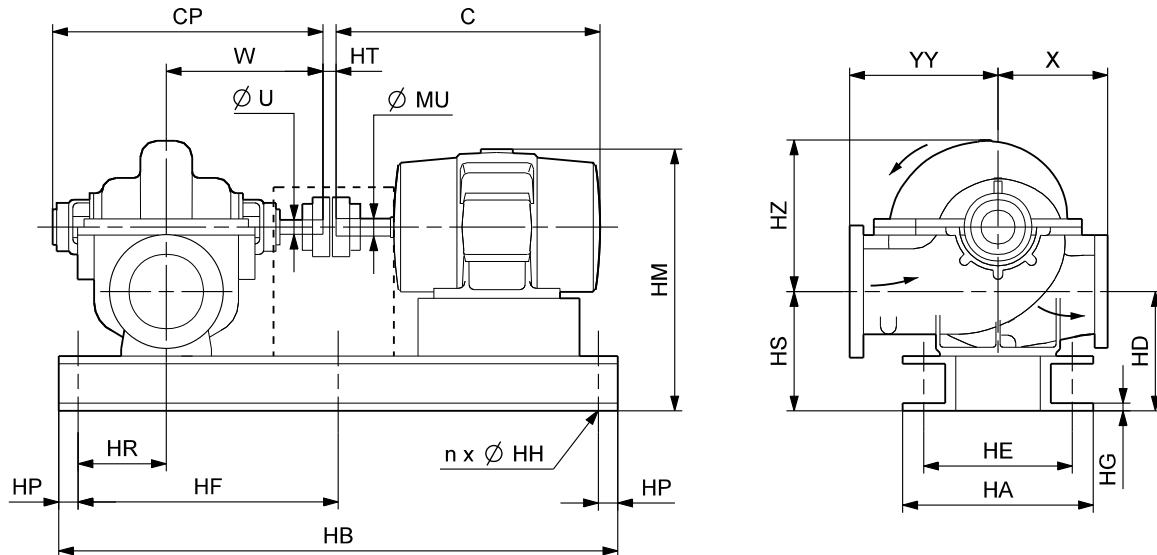

TM04 1828 1108

Dimensions

Motor			Pump dimensions [mm]									Motor dimensions [mm]			Distance between shaft ends [mm]
P ₂ [kW]	Frame size	Number of poles	CP		W	ØU	X	YY	HD	HS	HZ	C	HM	ØMU	HT
			Mechanical seal	Stuffing box											
18.5	160L	2	510	545	305	25.40	216	216	259	259	270	652	565	42	3.2
22	180MA	2	510	545	305	25.40	216	216	264	264	270	672	594	48	7.4
30	200LA	2	510	545	305	25.40	216	216	334	334	270	775	692	55	10.6
37	200LA	2	510	545	305	25.40	216	216	334	334	270	775	692	55	10.6
45	225MA	2	510	545	305	25.40	216	216	359	359	270	811	747	55	10.6
55	250SA	2	510	545	305	25.40	216	216	384	384	270	883	798	60	23.3
75	250MA	2	510	545	305	25.40	216	216	384	384	270	921	798	60	23.3

Motor			Base frame dimensions [mm]								Overhang [mm]			Net weights [kg]			Shipping volume [m ³]	
P ₂ [kW]	Frame size	Number of poles	HB	HP	HR	HF	HA	HE	HG	n	ØHH	Pump end		Motor end	Pump	Motor		Total
												Mechanical seal	Stuffing box					
18.5	160L	2	1130	200	10	-	440	380	10	4	18	-	30	40	73	158	361	0.409
22	180MA	2	1140	200	18	-	485	405	10	4	18	-	22	62	73	180	392	0.498
30	200LA	2	1230	200	20	-	535	460	11	4	23	-	20	80	73	280	524	0.738
37	200LA	2	1230	200	20	-	535	460	11	4	23	-	20	80	73	280	524	0.738
45	225MA	2	1250	200	20	-	600	525	11	4	23	-	20	96	73	355	619	0.927
55	250SA	2	1360	200	20	-	630	560	11	4	23	-	20	71	73	470	757	1.169
75	250MA	2	1360	200	20	-	630	560	11	4	23	-	20	109	73	540	827	1.200

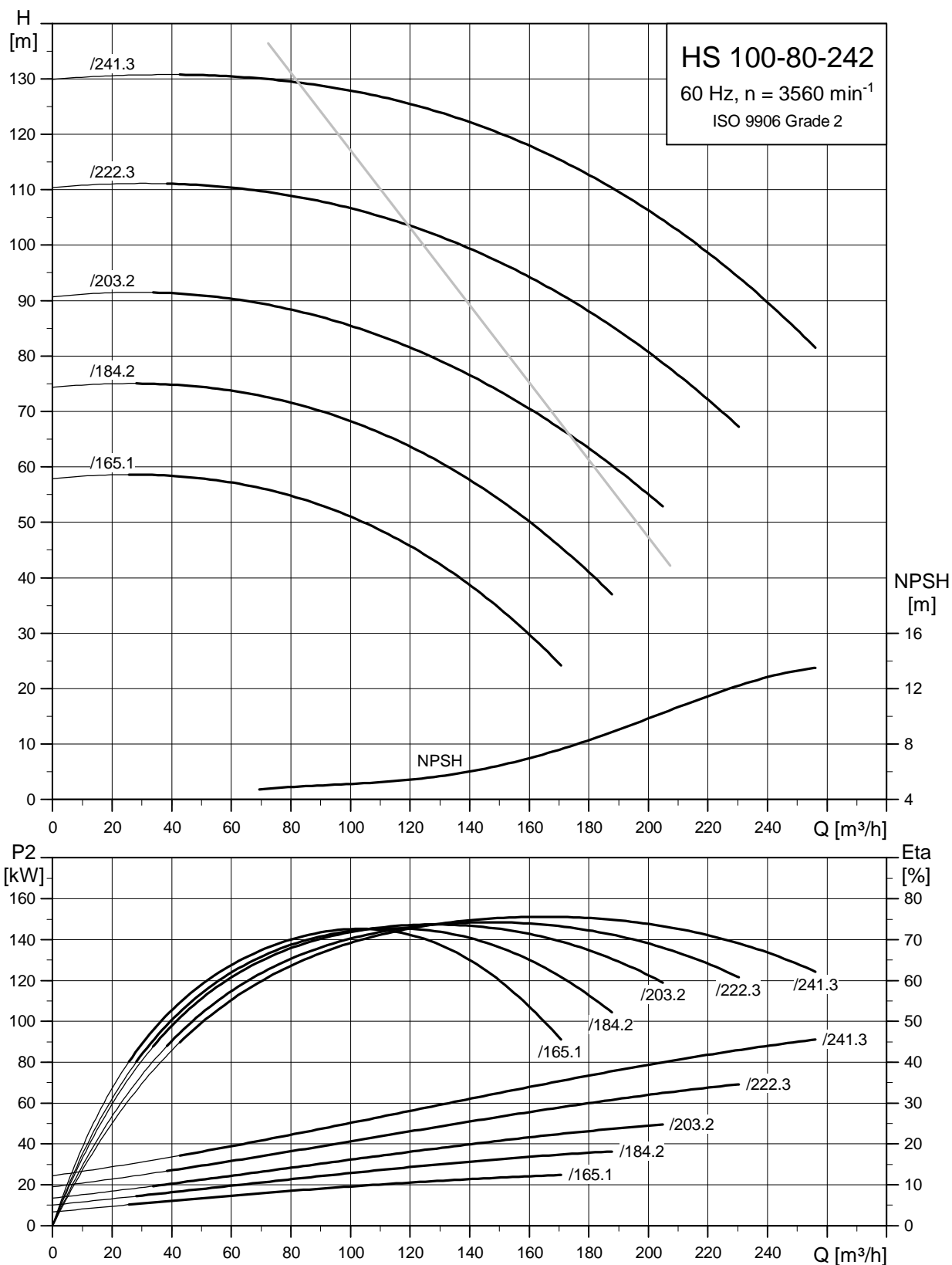

TM03 9847 450

The grey line represents a maximum shaft load of 1.27 kW/100 rpm for a $\text{Ø}25.4$ (1 inch) pump shaft when pumping water at the conditions mentioned on page 39. If the required shaft load exceeds 1.27 kW/100 rpm, use a pump with a $\text{Ø}30.2$ (1.19 inch) pump shaft.

Be aware that the curves will change when pumping liquids with a higher density and/or viscosity than water.

Dimensional sketch

HS standard, 100-80-242

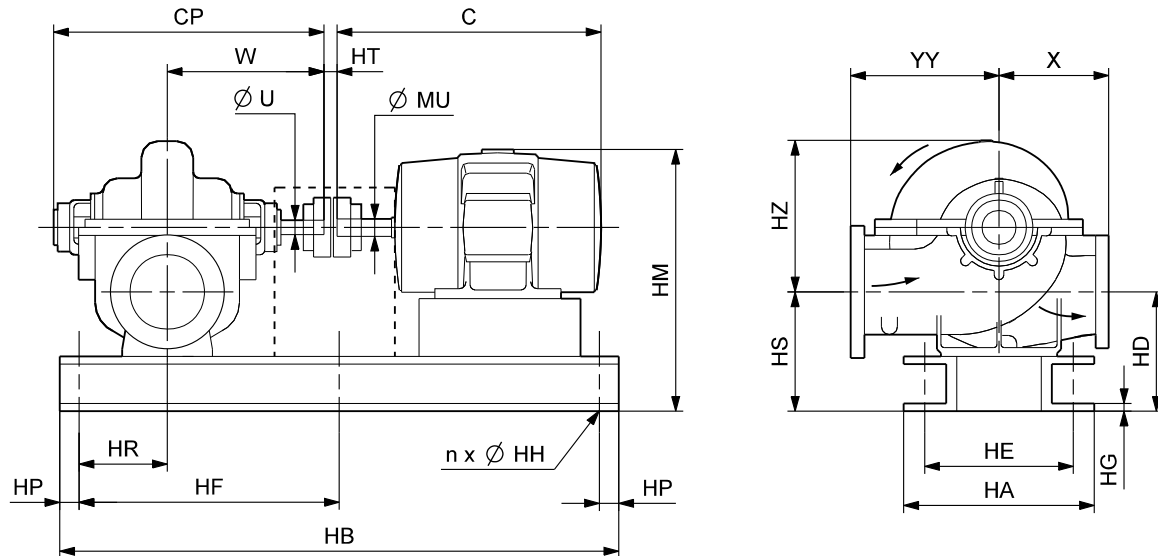

TMD04 1828 1108

Dimensions

Motor			Pump dimensions [mm]									Motor dimensions [mm]			Distance between shaft ends [mm]
P ₂ [kW]	Frame size	Number of poles	CP		W	ØU	X	YY	HD	HS	HZ	C	HM	ØMU	HT
			Mechanical seal	Stuffing box											
30	200LA	2	510	545	305	25.40	279	279	322	322	290	775	692	55	10.6
37	200LA	2	510	545	305	25.40	279	279	322	322	290	775	692	55	10.6
45	225MA	2	510	545	305	25.40	279	279	346	346	290	811	747	55	10.6
55	250SA	2	510	545	305	30.16	279	279	376	376	290	883	803	60	23.3
75	250MA	2	510	545	305	30.16	279	279	376	376	290	921	803	60	23.3
90	280SA	2	510	545	305	30.16	279	279	401	401	290	996	883	65	23.3
110	280MA	2	510	545	305	30.16	279	279	401	401	290	1047	883	65	23.3

Motor			Base frame dimensions [mm]										Overhang [mm]			Net weights [kg]			Shipping volume [m ³]
P ₂ [kW]	Frame size	Number of poles	HB	HP	HR	HF	HA	HE	HG	n	ØHH	Pump end		Motor end	Pump	Motor	Total		
												Mechanical seal	Stuffing box						
30	200LA	2	1230	200	20	-	510	440	11	4	23	-	20	80	80	280	526	0.752	
37	200LA	2	1230	200	20	-	510	440	11	4	23	-	20	80	80	280	526	0.752	
45	225MA	2	1250	200	20	-	545	470	11	4	23	-	20	96	80	355	606	0.901	
55	250SA	2	1360	200	20	-	630	560	11	4	23	-	20	71	80	470	774	1.176	
75	250MA	2	1360	200	20	-	630	560	11	4	23	-	20	109	80	540	844	1.207	
90	280SA	2	1450	200	20	-	680	610	11	4	23	-	20	94	80	630	929	1.490	
110	280MA	2	1450	200	20	-	680	610	11	4	23	-	20	145	80	700	999	1.538	

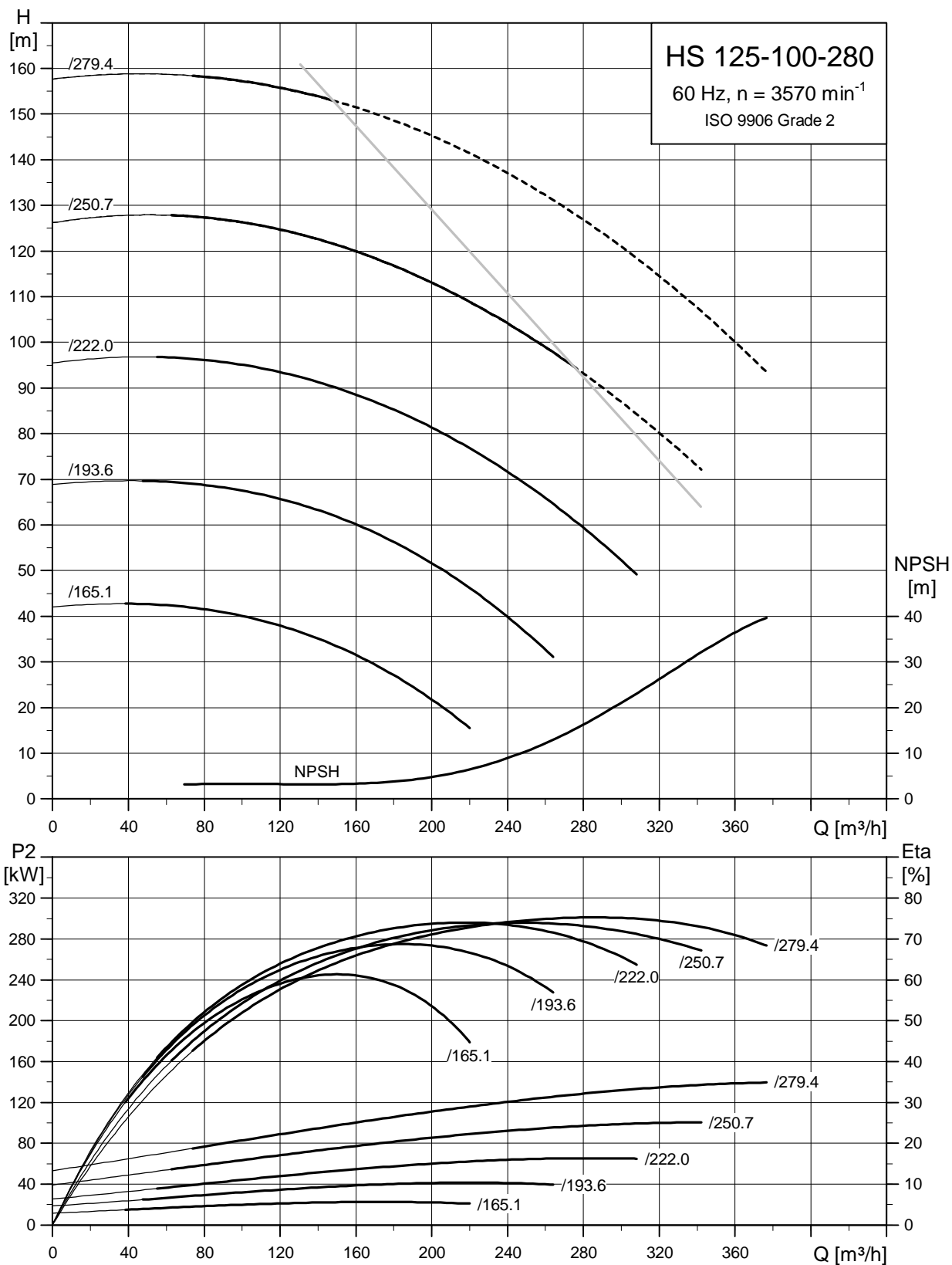

TM03 9850 4507

The grey line represents a maximum shaft load of 2.7 kW/100 rpm when pumping water at the conditions mentioned on page 39. If the required shaft load exceeds 2.7 kW/100 rpm, use a larger pump.
Be aware that the curves will change when pumping liquids with a higher density and/or viscosity than water.

Dimensional sketch

HS standard, 125-100-280

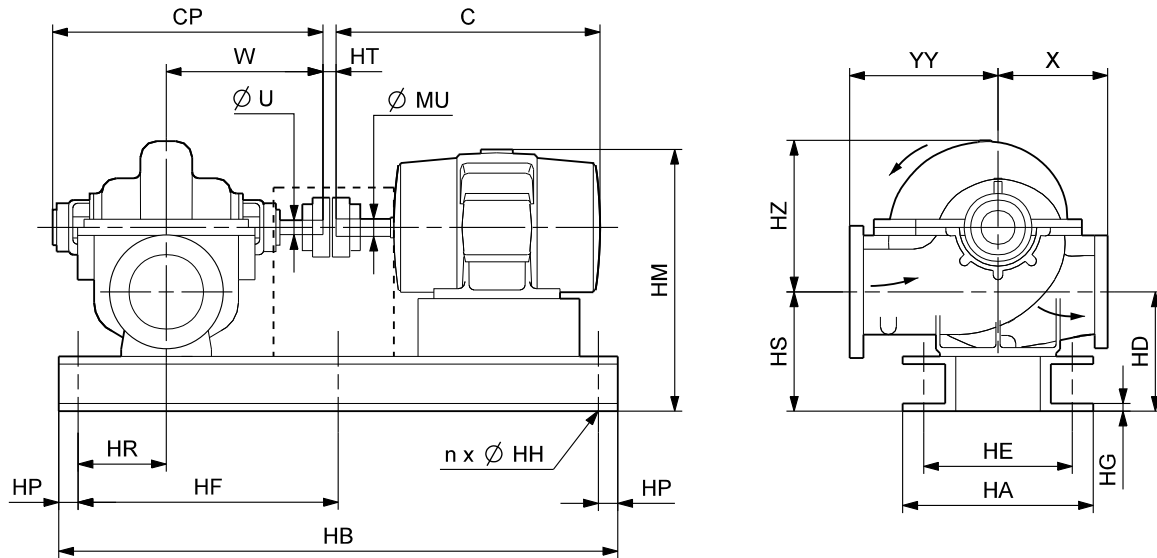

TM04 1828 1108

Dimensions

Motor			Pump dimensions [mm]									Motor dimensions [mm]			Distance between shaft ends [mm]
P ₂ [kW]	Frame size	Number of poles	CP		W	ØU	X	YY	HD	HS	HZ	C	HM	ØMU	HT
			Mechanical seal	Stuffing box											
30	200LA	2	631	674	368	38.10	305	305	344	344	370	775	746	55	13.0
37	200LA	2	631	674	368	38.10	305	305	344	344	370	775	746	55	13.0
45	225MA	2	631	674	368	38.10	305	305	344	344	370	811	776	55	13.0
55	250SA	2	631	674	368	38.10	305	305	344	344	370	883	802	60	25.7
75	250MA	2	631	674	368	38.10	305	305	344	344	370	921	802	60	25.7
90	280SA	2	631	674	368	38.10	305	305	370	370	370	996	883	65	25.7
110	280MA	2	631	674	368	38.10	305	305	370	370	370	1047	883	65	25.7

Motor			Base frame dimensions [mm]										Overhang [mm]			Net weights [kg]			Shipping volume [m ³]
P ₂ [kW]	Frame size	Number of poles	HB	HP	HR	HF	HA	HE	HG	n	ØHH	Pump end		Motor end	Pump	Motor	Total		
												Mechanical seal	Stuffing box						
30	200LA	2	1320	200	50	-	485	415	11	4	23	13	56	86	164	280	625	0.925	
37	200LA	2	1320	200	50	-	485	415	11	4	23	13	56	86	164	280	625	0.925	
45	225MA	2	1350	200	50	-	535	465	11	4	23	13	56	92	164	355	710	1.064	
55	250SA	2	1450	200	50	-	600	530	11	4	23	13	56	76	164	470	838	1.266	
75	250MA	2	1450	200	50	-	600	530	11	4	23	13	56	114	164	540	908	1.296	
90	280SA	2	1550	200	50	575	650	580	11	6	23	13	56	90	164	630	1018	1.587	
110	280MA	2	1550	200	50	575	650	580	11	6	23	13	56	141	164	700	1088	1.635	

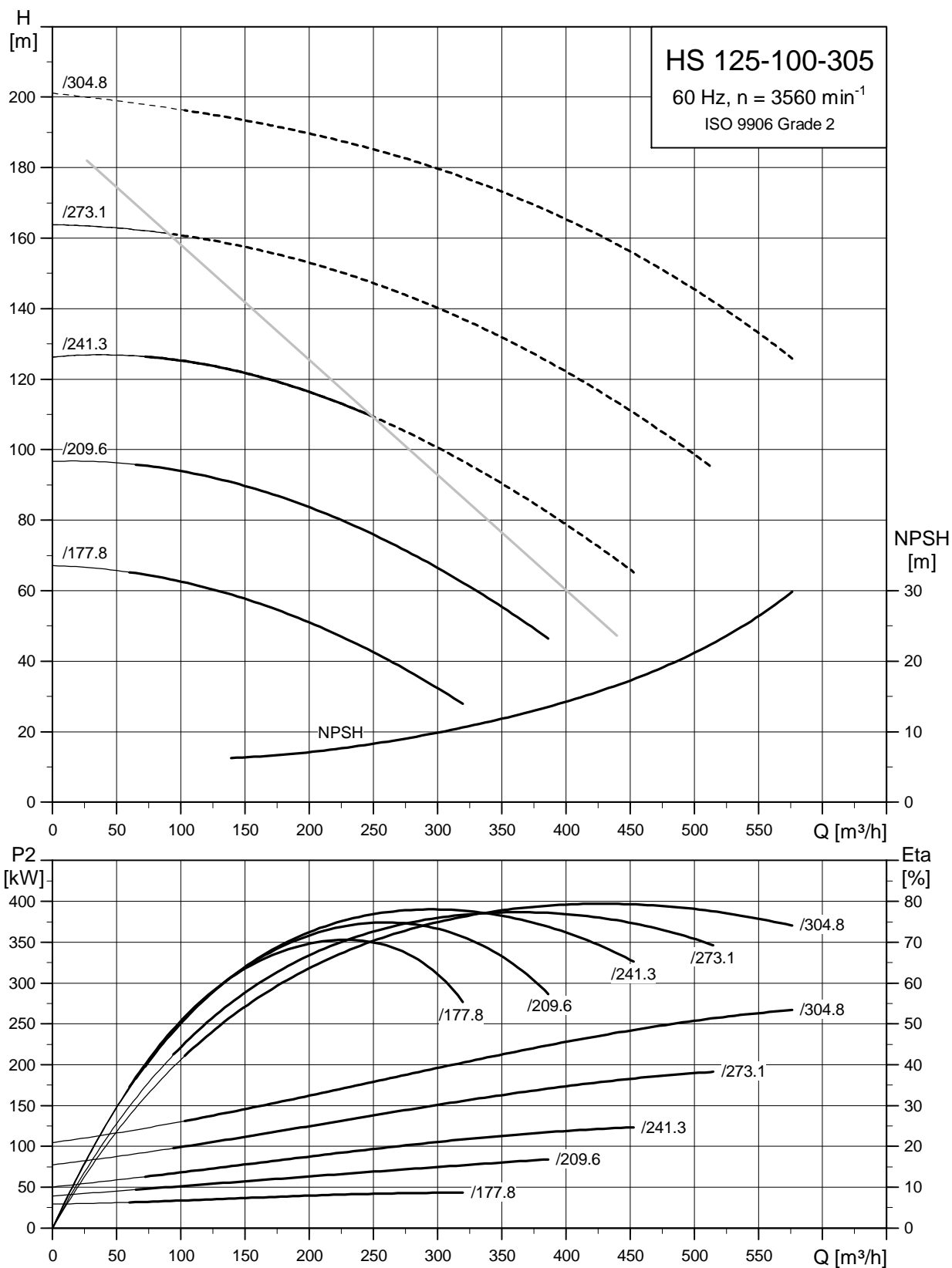

TM03 9852 450

The grey line represents a maximum shaft load of 2.7 kW/100 rpm when pumping water at the conditions mentioned on page 39. If the required shaft load exceeds 2.7 kW/100 rpm, use a larger pump. Be aware that the curves will change when pumping liquids with a higher density and/or viscosity than water.

Dimensional sketch

HS standard, 125-100-305

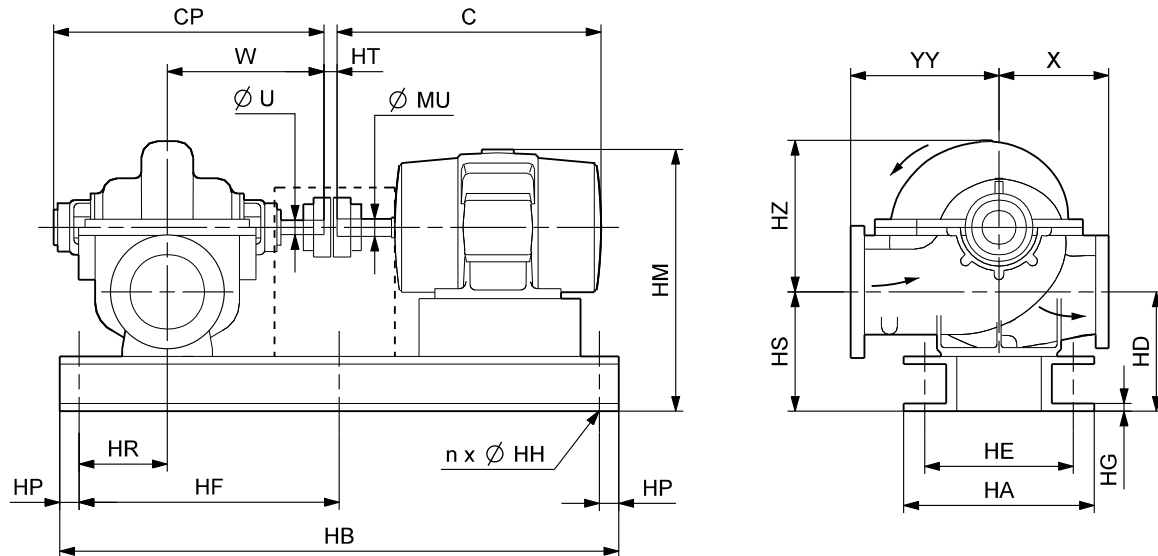

TM04 1828 1108

Dimensions

Motor			Pump dimensions [mm]									Motor dimensions [mm]			Distance between shaft ends [mm]
P ₂ [kW]	Frame size	Number of poles	CP		W	ØU	X	YY	HD	HS	HZ	C	HM	ØMU	HT
			Mechanical seal	Stuffing box											
55	250SA	2	631	674	368	38.10	305	305	344	344	370	883	802	60	25.7
75	250MA	2	631	674	368	38.10	305	305	344	344	370	921	802	60	25.7
90	280SA	2	631	674	368	38.10	305	305	370	370	370	996	883	65	25.7
110	280MA	2	631	674	368	38.10	305	305	370	370	370	1047	883	65	25.7

Motor			Base frame dimensions [mm]									Overhang [mm]			Net weights [kg]			Shipping volume [m ³]
P ₂ [kW]	Frame size	Number of poles	HB	HP	HR	HF	HA	HE	HG	n	ØHH	Pump end		Motor end	Pump	Motor	Total	
												Mechanical seal	Stuffing box					
55	250SA	2	1450	200	50	-	600	530	11	4	23	13	56	76	164	470	838	1.266
75	250MA	2	1450	200	50	-	600	530	11	4	23	13	56	114	164	540	908	1.296
90	280SA	2	1550	200	50	575	650	580	11	6	23	13	56	90	164	630	1018	1.587
110	280MA	2	1550	200	50	575	650	580	11	6	23	13	56	141	164	700	1088	1.635

4-pole

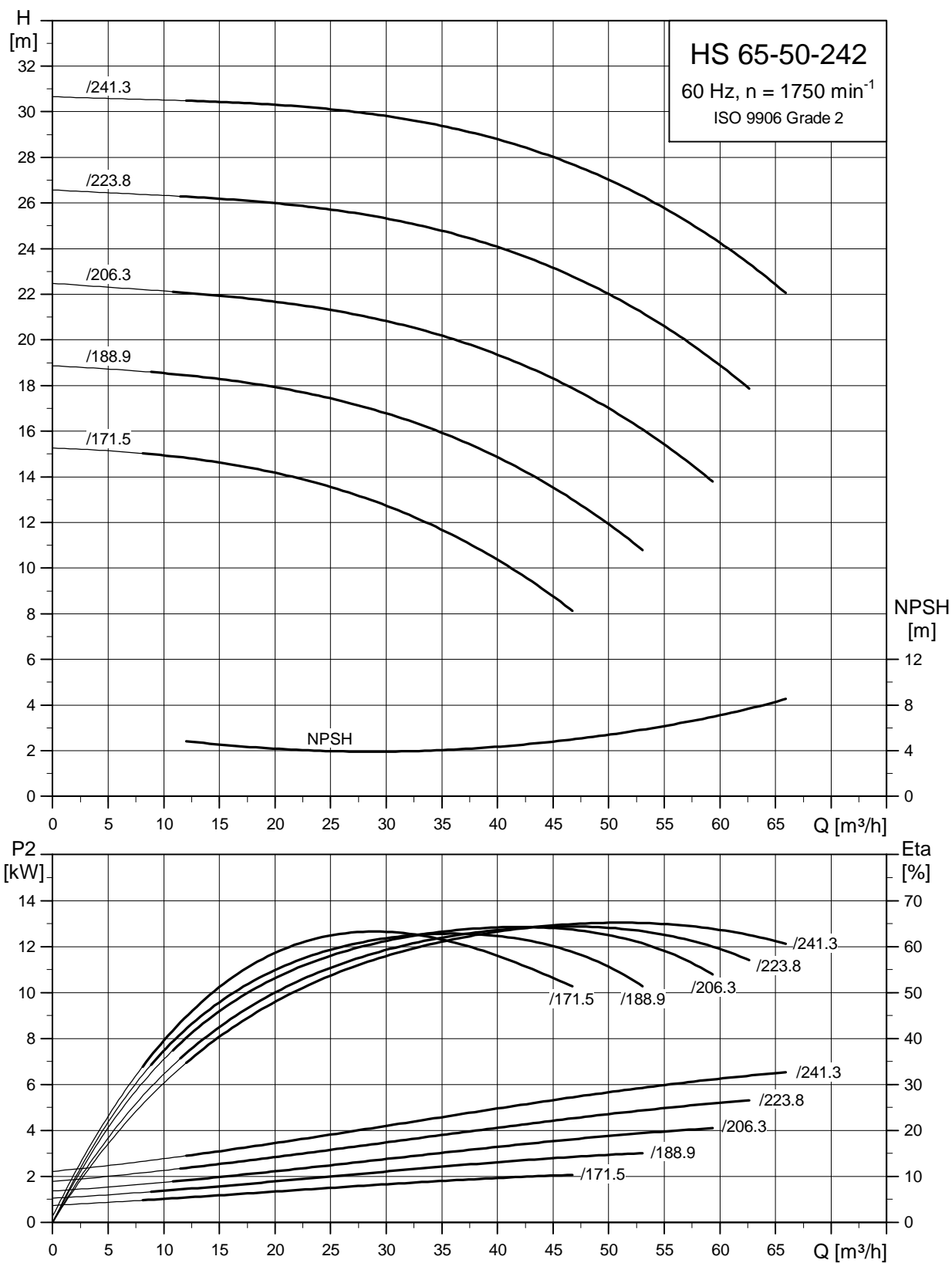

TM03 9843 4507

Dimensional sketch

HS standard, 65-50-242

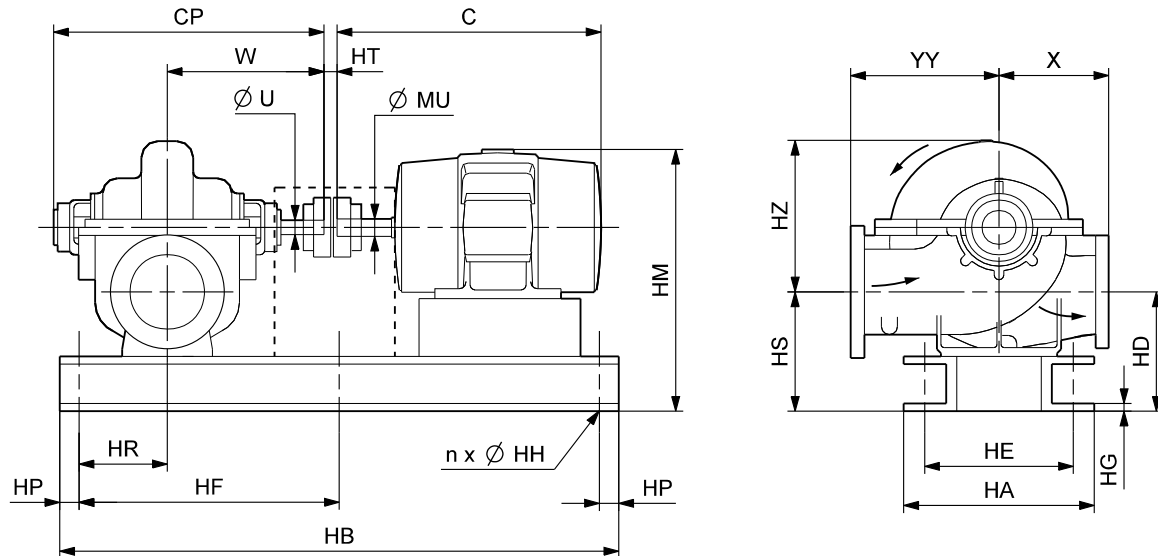

TM04 1828 1108

Dimensions

Motor			Pump dimensions [mm]									Motor dimensions [mm]			Distance between shaft ends [mm]
P ₂ [kW]	Frame size	Number of poles	CP		W	ØU	X	YY	HD	HS	HZ	C	HM	ØMU	HT
			Mechanical seal	Stuffing box											
2.2	100L	4	510	545	305	25.40	216	216	259	259	270	375	491	28	3.2
3	100L	4	510	545	305	25.40	216	216	259	259	270	375	491	28	3.2
3.7	112M	4	510	545	305	25.40	216	216	259	259	270	392	501	28	3.2
4	112M	4	510	545	305	25.40	216	216	259	259	270	392	501	28	3.2
5.5	132S	4	510	545	305	25.40	216	216	259	259	270	454	526	38	3.2
7.5	132M	4	510	545	305	25.40	216	216	259	259	270	492	526	38	3.2
11	160M	4	510	545	305	25.40	216	216	259	259	270	608	565	42	3.2

Motor			Base frame dimensions [mm]										Overhang [mm]			Net weights [kg]			Shipping volume [m ³]
P ₂ [kW]	Frame size	Number of poles	HB	HP	HR	HF	HA	HE	HG	n	ØHH	Pump end		Motor end	Pump	Motor	Total		
												Mechanical seal	Stuffing box						
2.2	100L	4	920	200	20	-	360	300	10	4	18	-	20	-	73	35	202	0.268	
3	100L	4	920	200	20	-	360	300	10	4	18	-	20	-	73	35	202	0.268	
3.7	112M	4	940	200	20	-	360	300	10	4	18	-	20	-	73	46	218	0.274	
4	112M	4	940	200	20	-	360	300	10	4	18	-	20	-	73	46	218	0.274	
5.5	132S	4	1000	200	10	-	360	300	10	4	18	-	30	-	73	75	248	0.300	
7.5	132M	4	1000	200	10	-	360	300	10	4	18	-	30	10	73	82	255	0.303	
11	160M	4	1130	200	10	-	440	380	10	4	18	-	30	-	73	130	333	0.395	

Performance curves

HS 65-50-331
4-pole

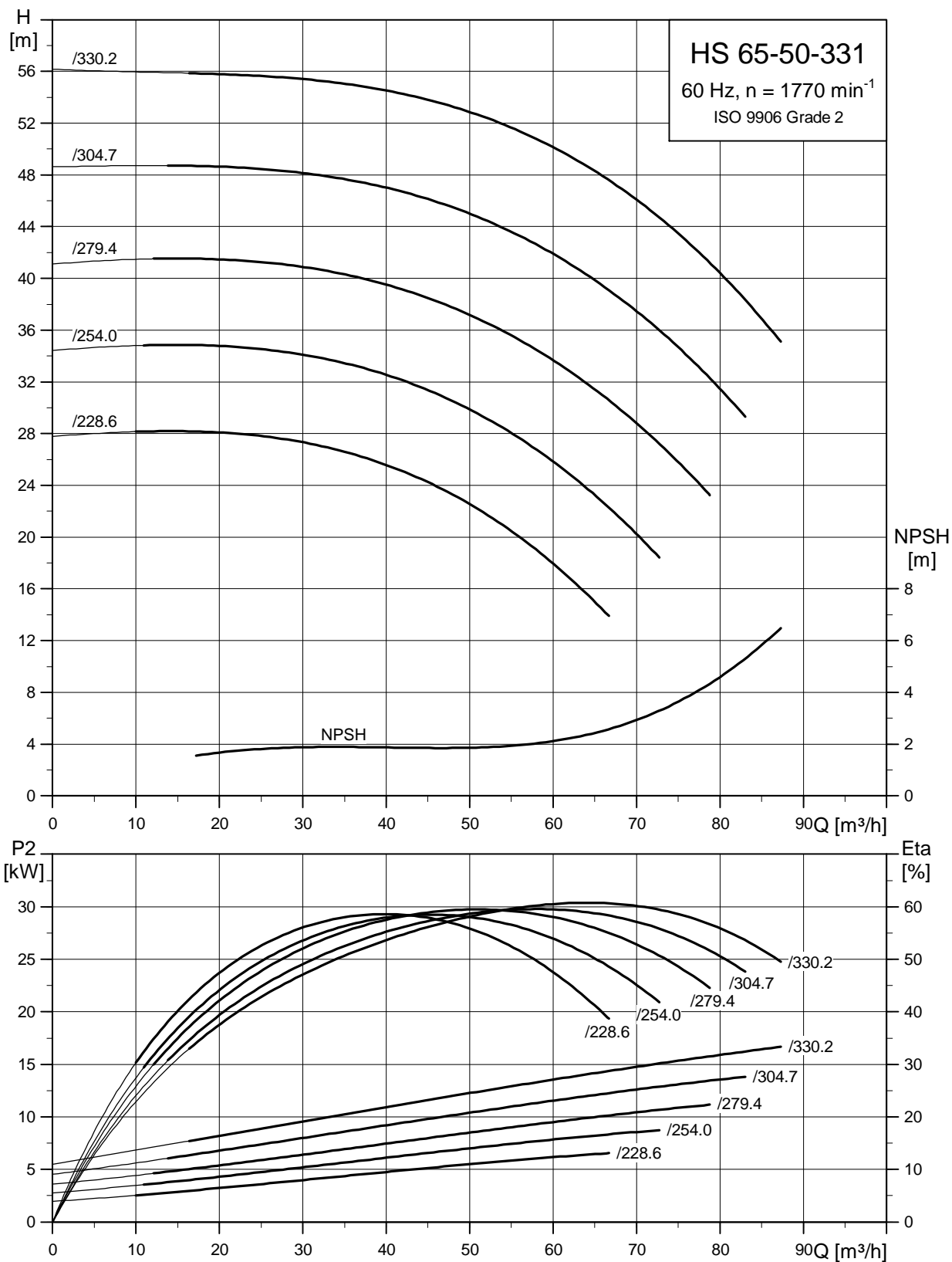

TM03 9845 4507

Dimensional sketch

HS standard, 65-50-331

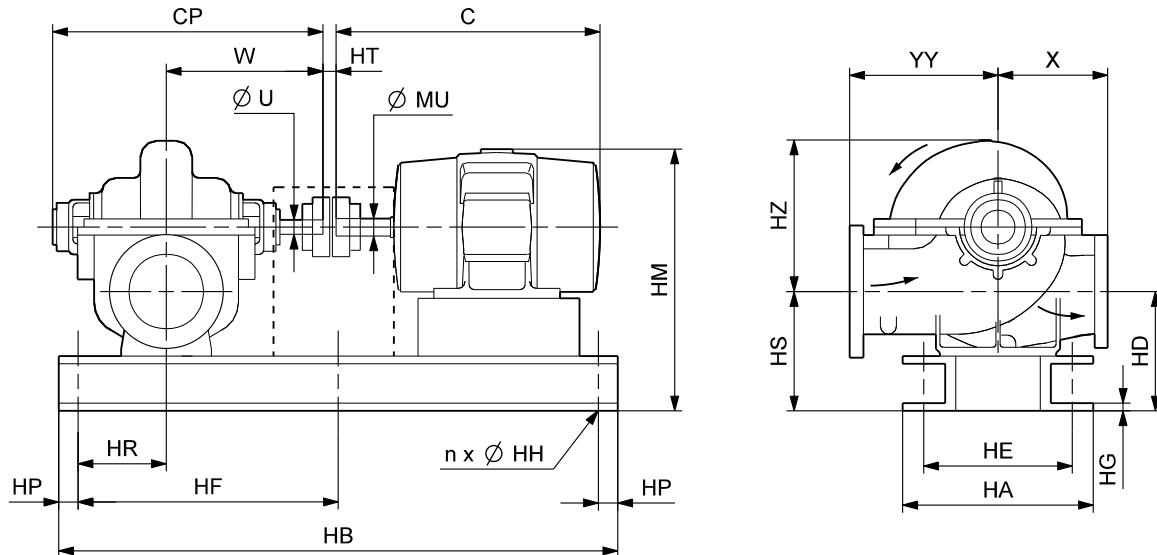

TM04 1828 1108

Dimensions

Motor			Pump dimensions [mm]									Motor dimensions [mm]			Distance between shaft ends [mm]
P ₂ [kW]	Frame size	Number of poles	CP		W	ØU	X	YY	HD	HS	HZ	C	HM	ØMU	HT
			Mechanical seal	Stuffing box											
7.5	132M	4	510	545	305	25.40	254	254	259	259	355	492	564	38	3.2
11	160M	4	510	545	305	25.40	254	254	259	259	355	608	603	42	3.2
15	160L	4	510	545	305	25.40	254	254	259	259	355	652	603	42	3.2
18.5	180MC	4	510	545	305	25.40	254	254	259	259	355	672	627	48	7.5
22	180LC	4	510	545	305	25.40	254	254	259	259	355	710	627	48	7.5

Motor			Base frame dimensions [mm]								Overhang [mm]			Net weights [kg]			Shipping volume [m ³]	
P ₂ [kW]	Frame size	Number of poles	HB	HP	HR	HF	HA	HE	HG	n	ØHH	Pump end		Motor end	Pump	Motor		Total
												Mechanical seal	Stuffing box					
7.5	132M	4	1010	200	20	-	360	300	10	4	18	-	20	10	95	82	283	0.405
11	160M	4	1140	200	20	-	405	345	10	4	18	-	20	-	95	130	351	0.460
15	160L	4	1140	200	20	-	405	345	10	4	18	-	20	40	95	158	379	0.476
18.5	180MC	4	1180	200	18	-	440	380	10	4	18	-	22	22	95	166	406	0.536
22	180LC	4	1180	200	18	-	440	380	10	4	18	-	22	60	95	205	445	0.553

Performance curves

HS 100-80-242
4-pole

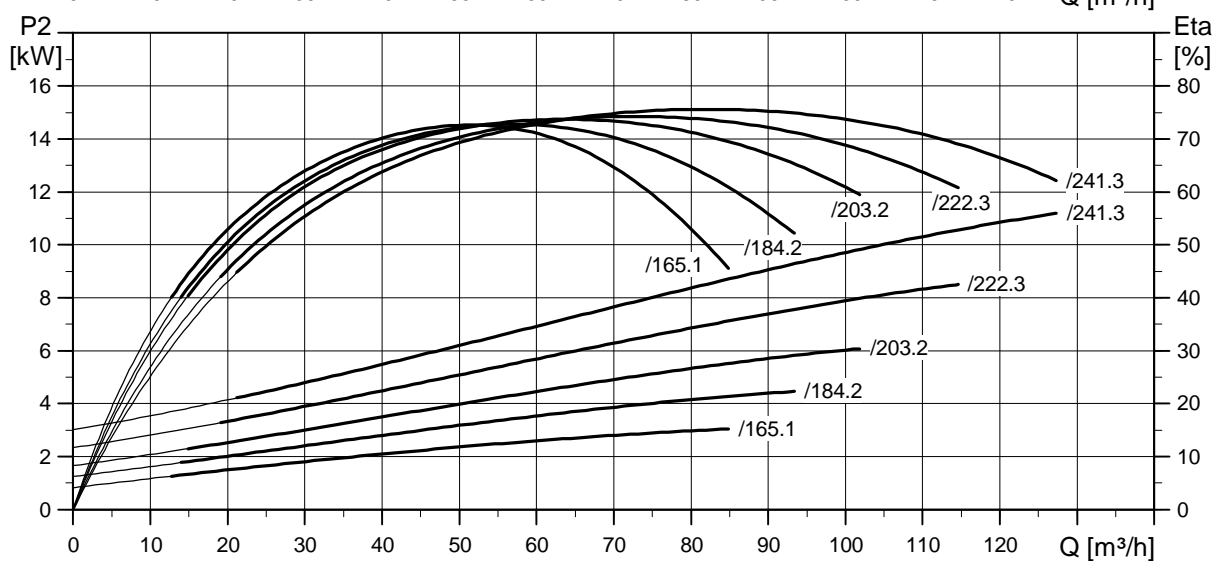
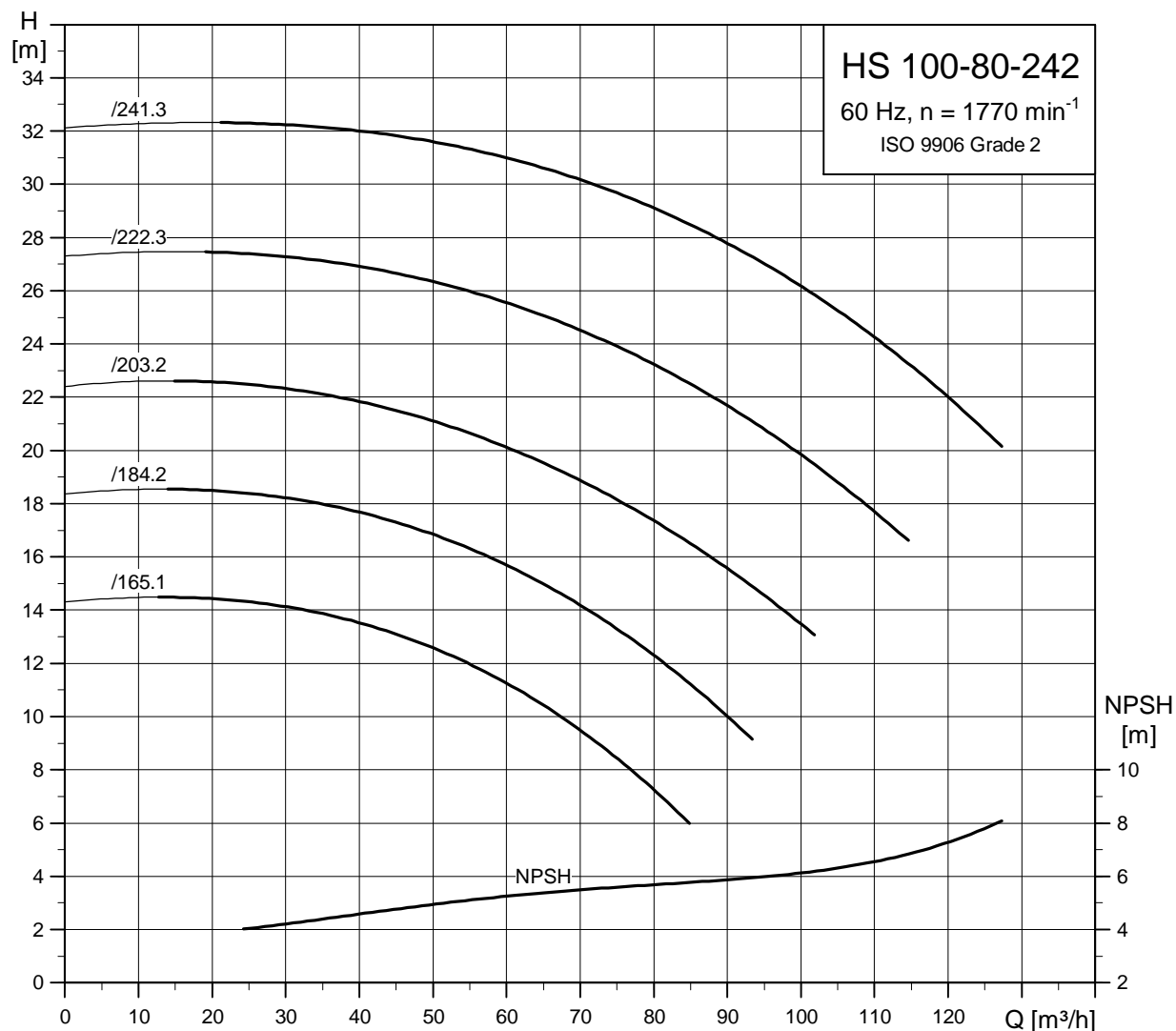

TM03 9846 4507

Dimensional sketch

HS standard, 100-80-242

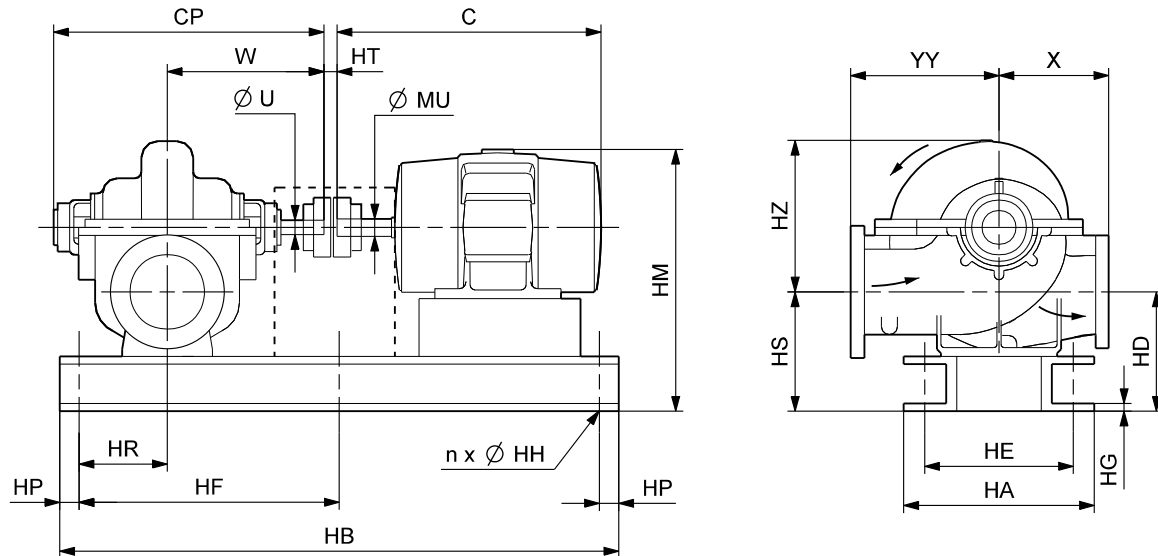

TM04 1828 1108

Dimensions

Motor			Pump dimensions [mm]									Motor dimensions [mm]			Distance between shaft ends [mm]
P ₂ [kW]	Frame size	Number of poles	CP		W	ØU	X	YY	HD	HS	HZ	C	HM	ØMU	HT
			Mechanical seal	Stuffing box											
4	112M	4	510	545	305	25.40	279	279	272	272	290	392	526	28	3.2
5.5	132S	4	510	545	305	25.40	279	279	272	272	290	454	551	38	3.2
7.5	132M	4	510	545	305	25.40	279	279	272	272	290	492	551	38	3.2
11	160M	4	510	545	305	25.40	279	279	272	272	290	608	590	42	3.2
15	160L	4	510	545	305	25.40	279	279	272	272	290	652	590	42	3.2

Motor			Base frame dimensions [mm]										Overhang [mm]			Net weights [kg]			Shipping volume [m ³]
P ₂ [kW]	Frame size	Number of poles	HB	HP	HR	HF	HA	HE	HG	n	ØHH	Pump end		Motor end	Pump	Motor	Total		
												Mechanical seal	Stuffing box						
4	112M	4	930	200	20	-	360	300	10	4	18	-	20	-	80	46	230	0.373	
5.5	132S	4	1010	200	20	-	360	300	10	4	18	-	20	-	80	75	260	0.404	
7.5	132M	4	1010	200	20	-	360	300	10	4	18	-	20	10	80	82	267	0.408	
11	160M	4	1140	200	20	-	445	370	10	4	18	-	20	-	80	130	340	0.478	
15	160L	4	1140	200	20	-	445	370	10	4	18	-	20	40	80	158	368	0.495	

Performance curves

HS 100-80-356
4-pole

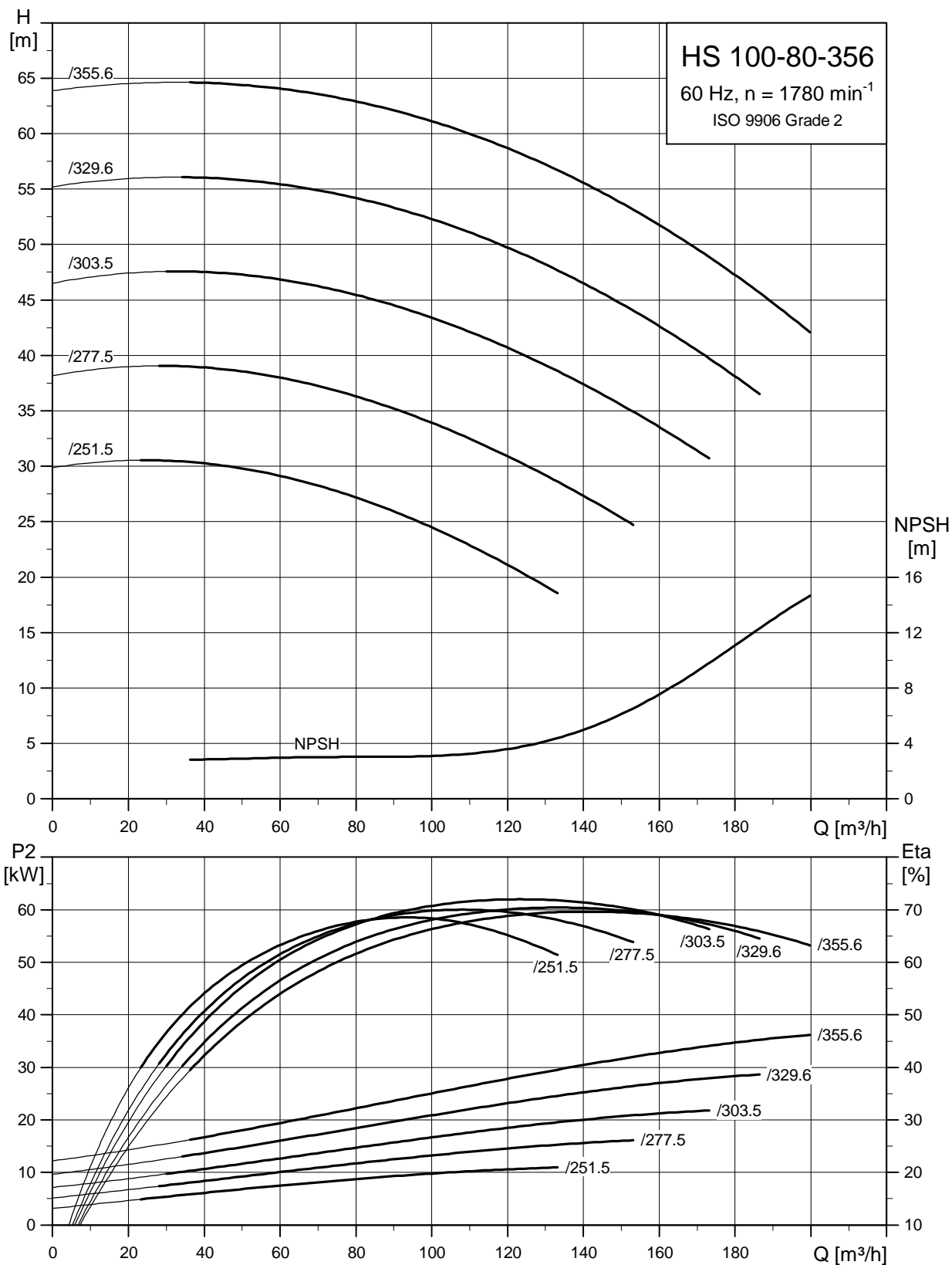

TM03 9848 4507

Dimensional sketch

HS standard, 100-80-356

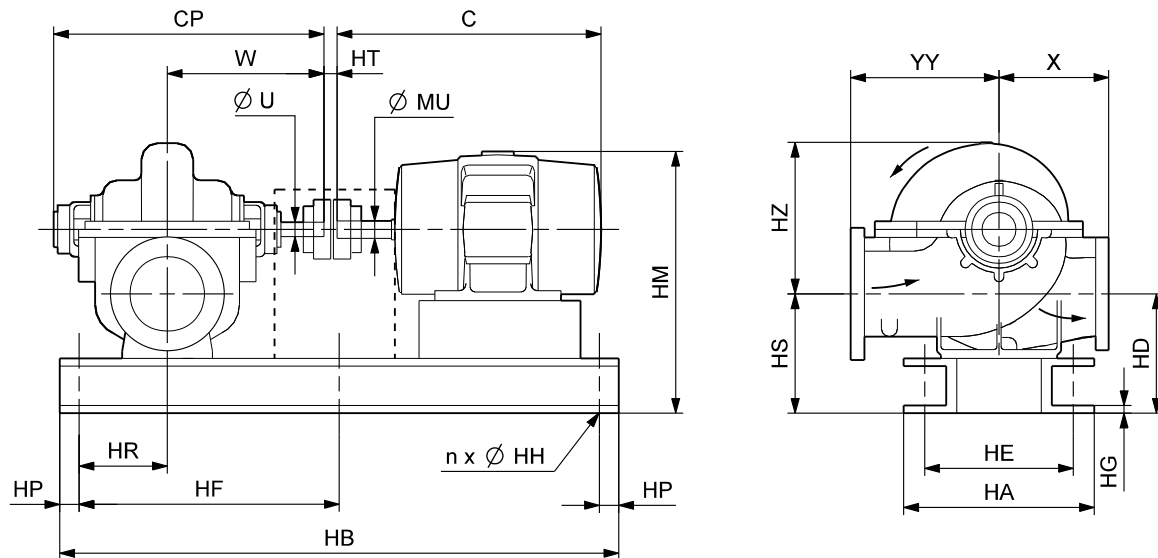

TM04 1828 1108

Dimensions

Motor			Pump dimensions [mm]									Motor dimensions [mm]			Distance between shaft ends [mm]
P ₂ [kW]	Frame size	Number of poles	CP		W	ØU	X	YY	HD	HS	HZ	C	HM	ØMU	HT
			Mechanical seal	Stuffing box											
11	160M	4	644	687	368	38.10	305	305	297	297	380	608	641	42	3.2
15	160L	4	644	687	368	38.10	305	305	297	297	380	652	641	42	3.2
18.5	180MC	4	644	687	368	38.10	305	305	297	297	380	672	665	48	3.2
22	180LC	4	644	687	368	38.10	305	305	297	297	380	710	665	48	3.2
30	200LC	4	644	687	368	38.10	305	305	347	347	380	775	743	55	3.2
37	225SC	4	644	687	368	38.10	305	305	352	352	380	816	778	60	13
45	225MC	4	644	687	368	38.10	305	305	352	352	380	841	778	60	13

Motor			Base frame dimensions [mm]									Overhang [mm]			Net weights [kg]			Shipping volume [m ³]
P ₂ [kW]	Frame size	Number of poles	HB	HP	HR	HF	HA	HE	HG	n	ØHH	Pump end		Motor end	Pump	Motor	Total	
												Mechanical seal	Stuffing box					
11	160M	4	1220	200	40	-	435	345	10	4	18	35	78	-	177	130	447	0.670
15	160L	4	1220	200	40	-	435	345	10	4	18	35	78	44	177	158	475	0.692
18.5	180MC	4	1260	200	40	-	450	380	10	4	23	35	78	24	177	166	502	0.703
22	180LC	4	1260	200	40	-	450	380	10	4	23	35	78	62	177	205	541	0.722
30	200LC	4	1300	200	40	-	495	415	11	4	23	35	78	86	177	280	633	0.923
37	225SC	4	1340	200	40	-	535	465	11	4	23	35	78	97	177	320	685	1.079
45	225MC	4	1370	200	40	-	535	465	11	4	23	35	78	92	177	360	725	1.096

Performance curves

HS 125-100-280
4-pole

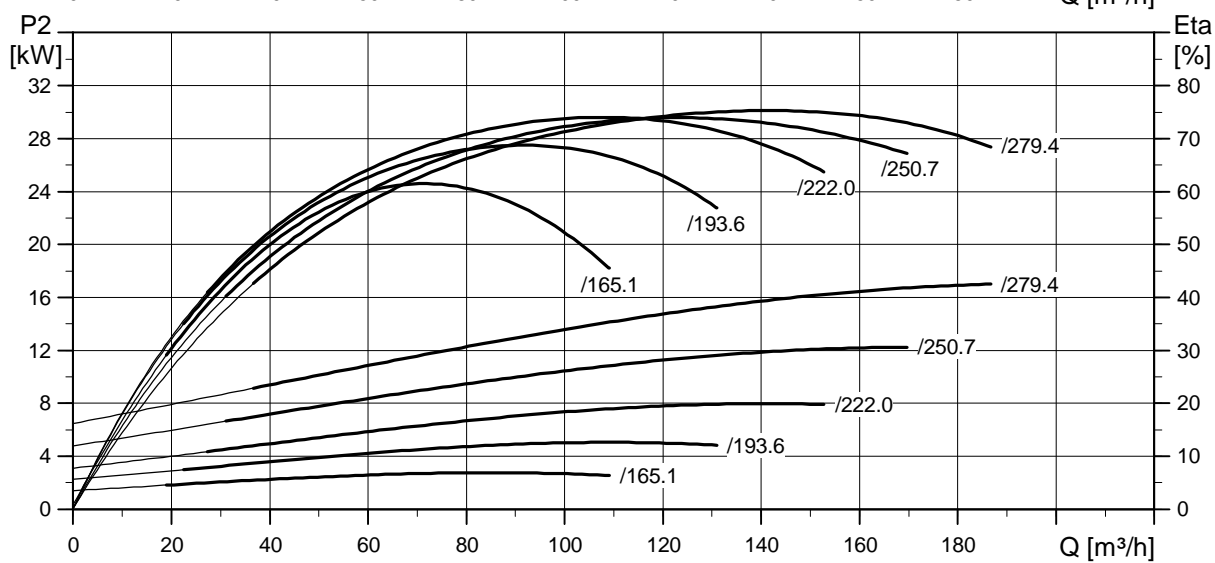
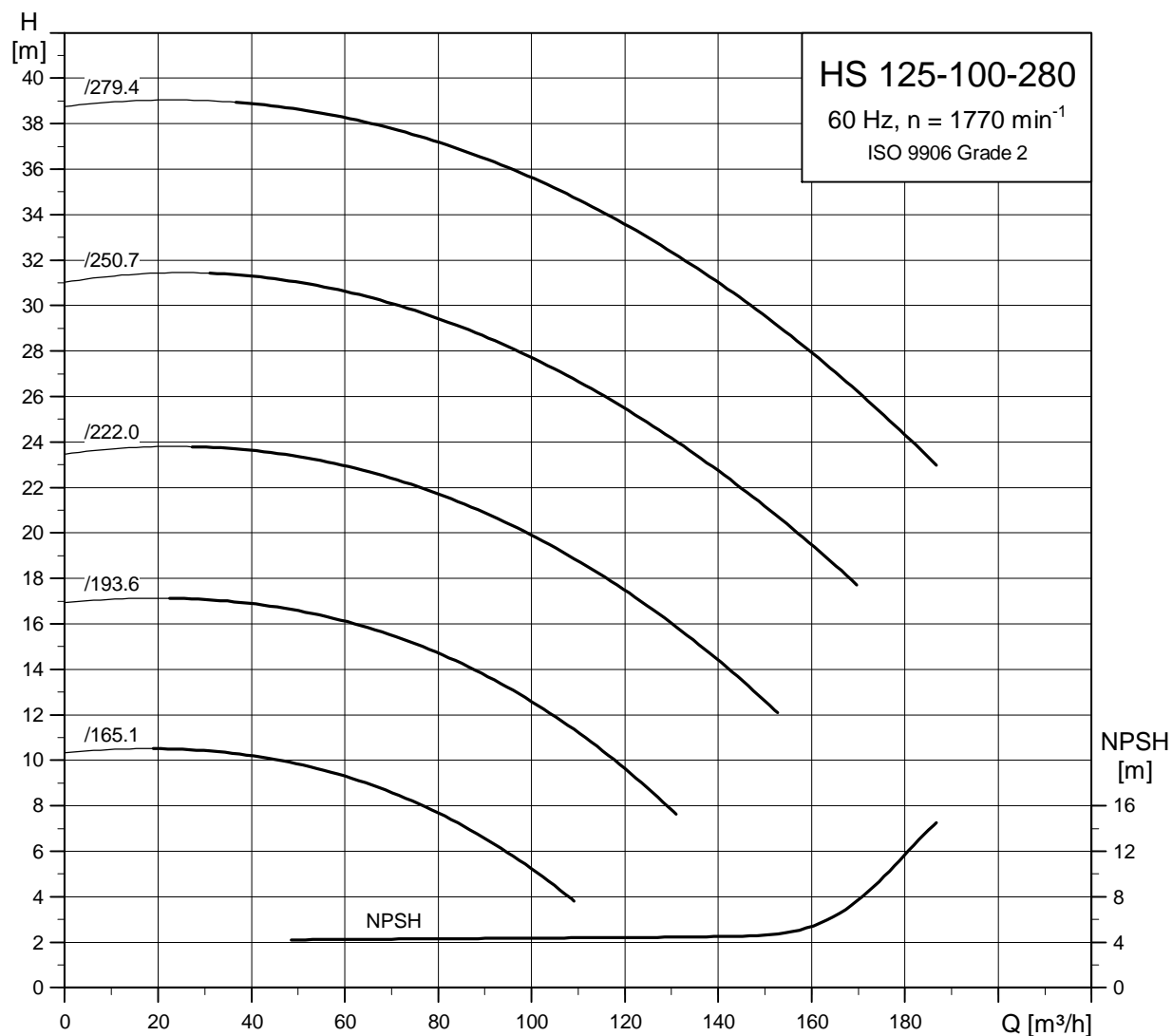

TM03 9849 4507

Dimensional sketch

HS standard, 125-100-280

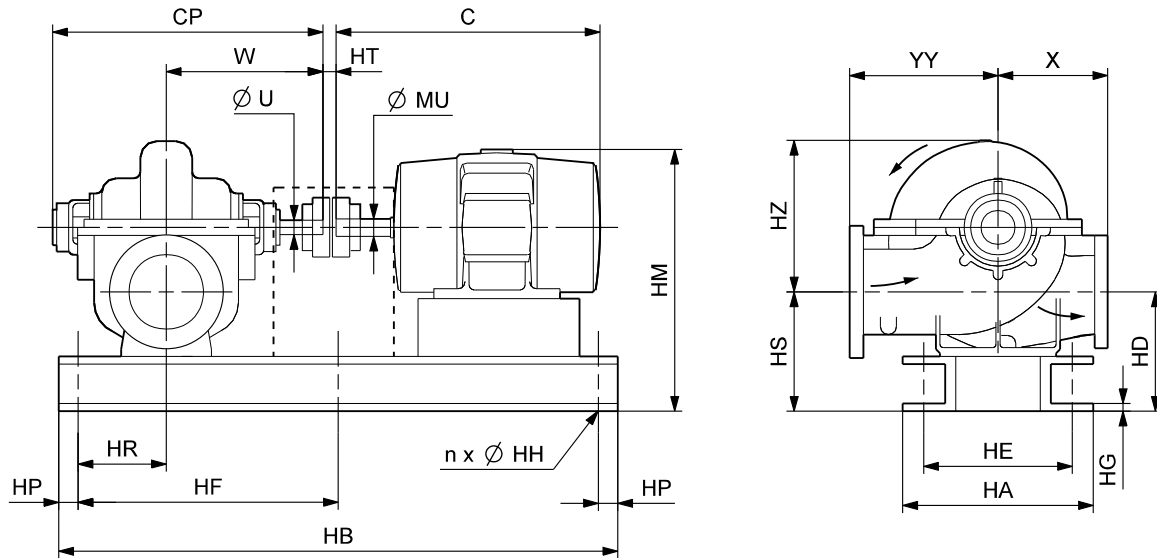

TMD04 1828 1108

Dimensions

Motor			Pump dimensions [mm]									Motor dimensions [mm]			Distance between shaft ends [mm]
P ₂ [kW]	Frame size	Number of poles	CP		W	ØU	X	YY	HD	HS	HZ	C	HM	ØMU	HT
			Mechanical seal	Stuffing box											
3.7	112M	4	631	674	368	38.10	305	305	294	294	370	392	580	28	3.2
4	112M	4	631	674	368	38.10	305	305	294	294	370	392	580	28	3.2
5.5	132S	4	631	674	368	38.10	305	305	294	294	370	454	605	38	3.2
7.5	132M	4	631	674	368	38.10	305	305	294	294	370	492	605	38	3.2
11	160M	4	631	674	368	38.10	305	305	294	294	370	608	644	42	3.2
15	160L	4	631	674	368	38.10	305	305	294	294	370	652	644	42	3.2
18.5	180MC	4	631	674	368	38.10	305	305	294	294	370	672	668	48	9.8
22	180LC	4	631	674	368	38.10	305	305	294	294	370	710	668	48	9.8

Motor			Base frame dimensions [mm]										Overhang [mm]			Net weights [kg]			Shipping volume [m ³]
P ₂ [kW]	Frame size	Number of poles	HB	HP	HR	HF	HA	HE	HG	n	ØHH	Pump end		Motor end	Pump	Motor	Total		
												Mechanical seal	Stuffing box						
												3.7	112M	4	1280	200	50	-	440
4	112M	4	1280	200	50	-	440	370	10	4	23	13	56	-	164	46	365	0.676	
5.5	132S	4	1100	200	50	-	360	300	10	4	18	13	56	-	164	75	364	0.585	
7.5	132M	4	1100	200	50	-	360	300	10	4	18	13	56	14	164	82	371	0.591	
11	160M	4	1280	200	50	-	440	370	10	4	23	13	56	-	164	130	451	0.676	
15	160L	4	1280	200	50	-	440	370	10	4	23	13	56	-	164	158	479	0.676	
18.5	180MC	4	1280	200	50	-	440	370	10	4	23	13	56	20	164	166	489	0.690	
22	180LC	4	1280	200	50	-	440	370	10	4	23	13	56	58	164	205	528	0.710	

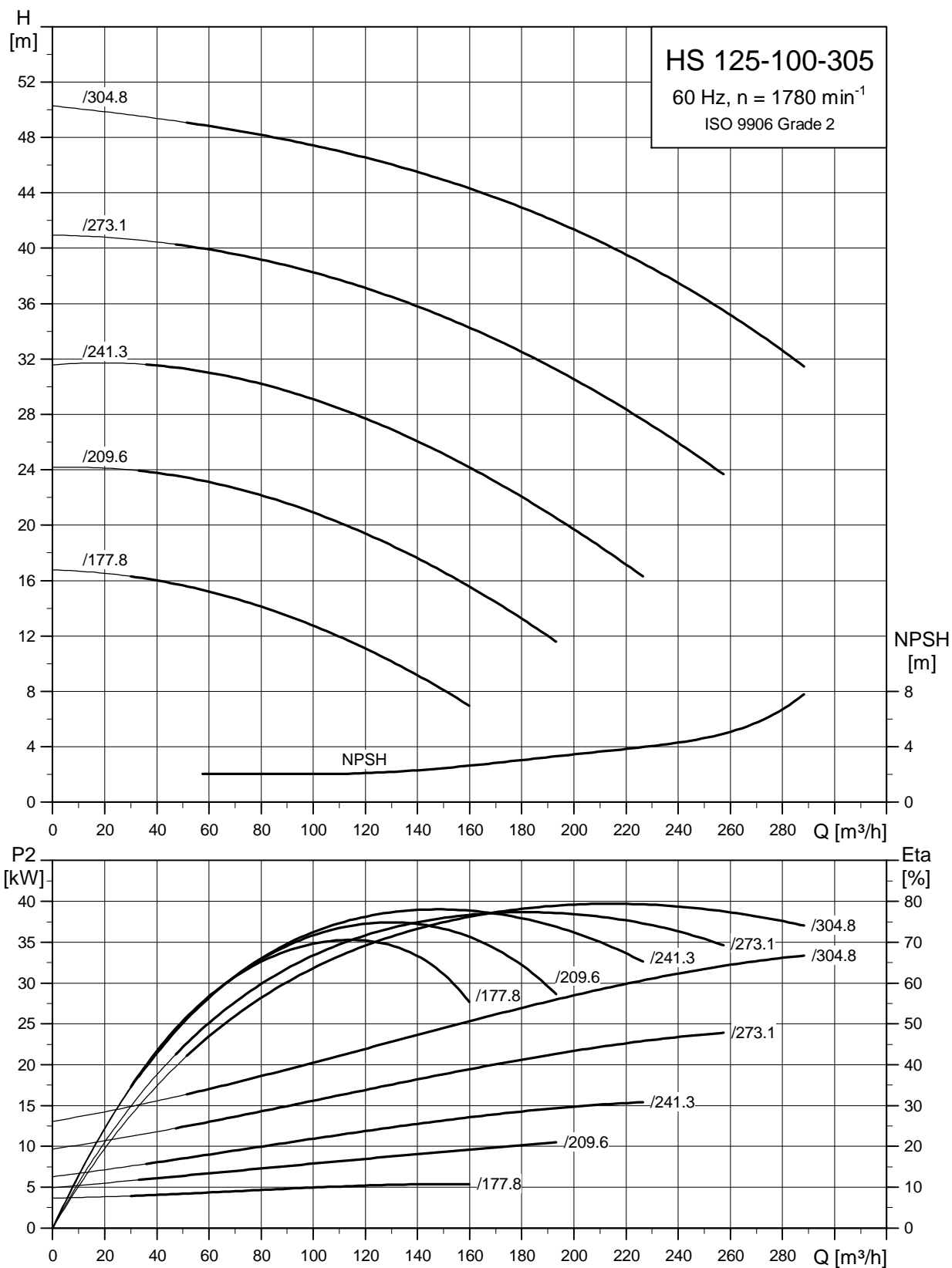

TM03 9851 4507

Dimensional sketch

HS standard, 125-100-305

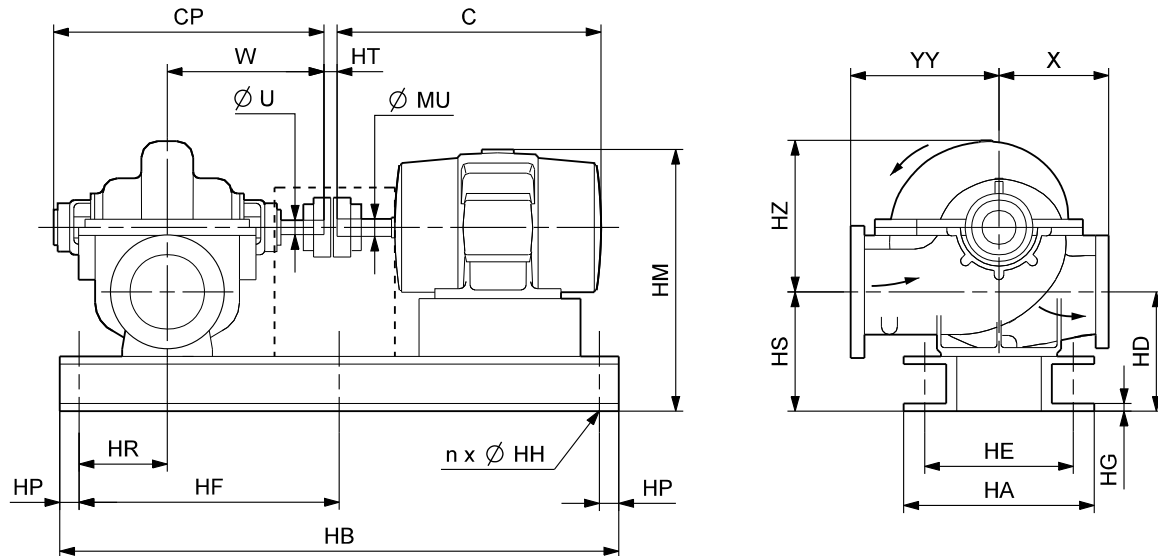

TMD04 1828 1108

Dimensions

Motor			Pump dimensions [mm]									Motor dimensions [mm]			Distance between shaft ends [mm]
P ₂ [kW]	Frame size	Number of poles	CP		W	ØU	X	YY	HD	HS	HZ	C	HM	ØMU	HT
			Mechanical seal	Stuffing box											
7.5	132M	4	631	674	368	38.10	305	305	294	294	370	492	605	38	3.2
11	160M	4	631	674	368	38.10	305	305	294	294	370	608	644	42	3.2
15	160L	4	631	674	368	38.10	305	305	294	294	370	652	644	42	3.2
18.5	180MC	4	631	674	368	38.10	305	305	294	294	370	672	668	48	9.8
22	180LC	4	631	674	368	38.10	305	305	294	294	370	710	668	48	9.8
30	200LC	4	631	674	368	38.10	305	305	344	344	370	775	746	55	13
37	225SC	4	631	674	368	38.10	305	305	344	344	370	816	776	60	25.7
45	225MC	4	631	674	368	38.10	305	305	344	344	370	841	776	60	25.7

Motor			Base frame dimensions [mm]									Overhang [mm]			Net weights [kg]			Shipping volume [m ³]
P ₂ [kW]	Frame size	Number of poles	HB	HP	HR	HF	HA	HE	HG	n	ØHH	Pump end		Motor end	Pump	Motor	Total	
												Mechanical seal	Stuffing box					
												7.5	132M	4	1100	200	50	-
11	160M	4	1280	200	50	-	440	370	10	4	23	13	56	-	164	130	449	0.676
15	160L	4	1280	200	50	-	440	370	10	4	23	13	56	-	164	158	477	0.676
18.5	180MC	4	1280	200	50	-	440	370	10	4	23	13	56	20	164	166	489	0.690
22	180LC	4	1280	200	50	-	440	370	10	4	23	13	56	58	164	205	528	0.710
30	200LC	4	1320	200	50	-	485	415	11	4	23	13	56	86	164	280	625	0.925
37	225SC	4	1370	200	50	-	535	465	11	4	23	13	56	90	164	320	678	1.076
45	225MC	4	1390	200	50	-	535	465	11	4	23	13	56	95	164	360	718	1.094

Performance curves

HS 125-100-381
4-pole

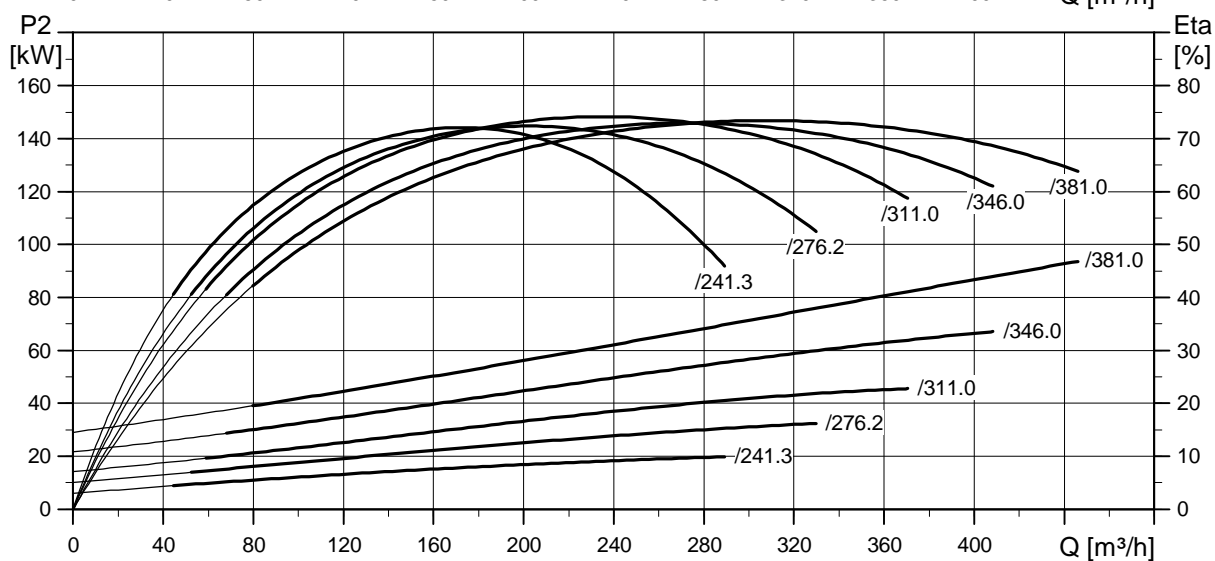
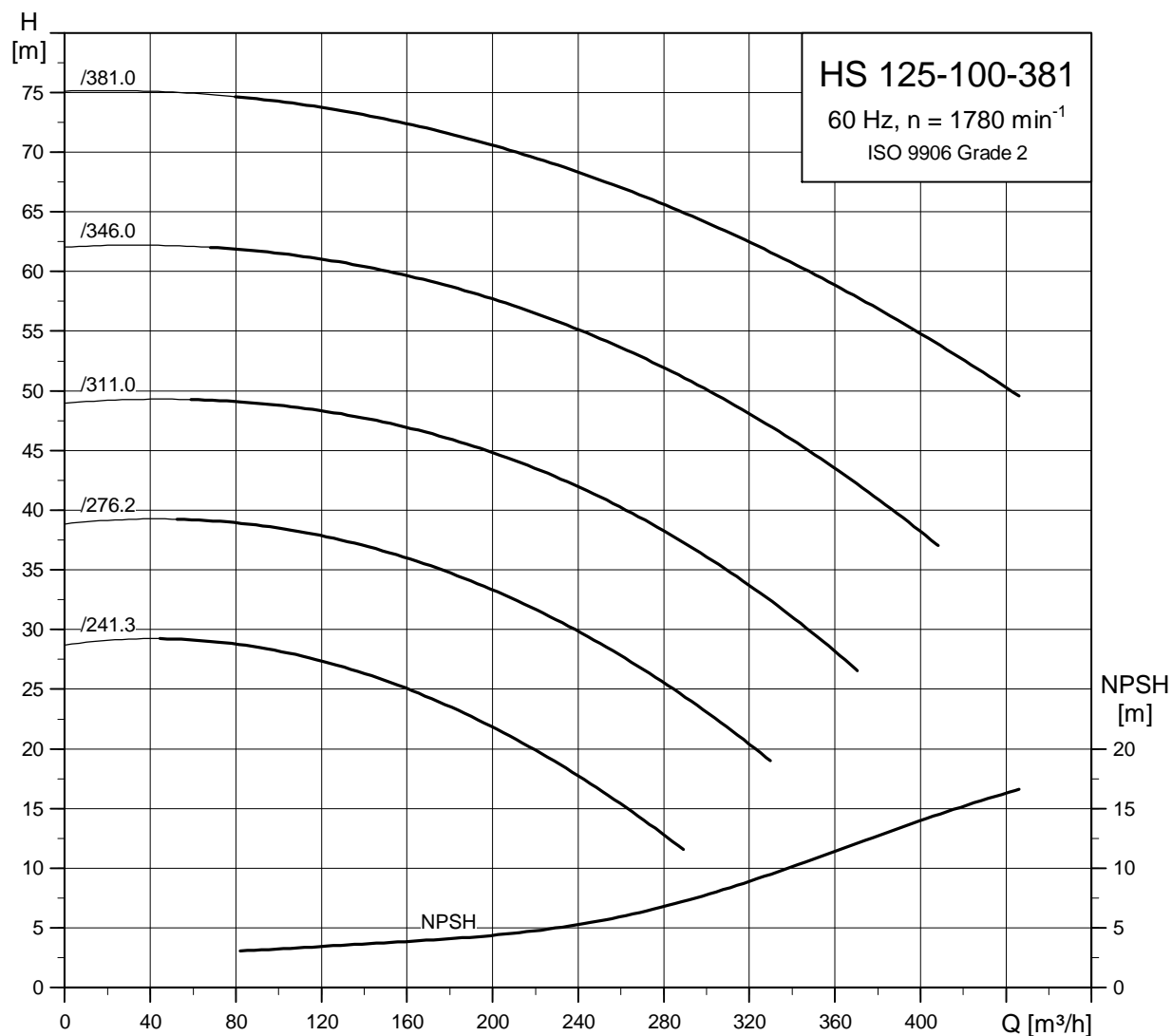

TM03 9853 4507

Dimensional sketch

HS standard, 125-100-381

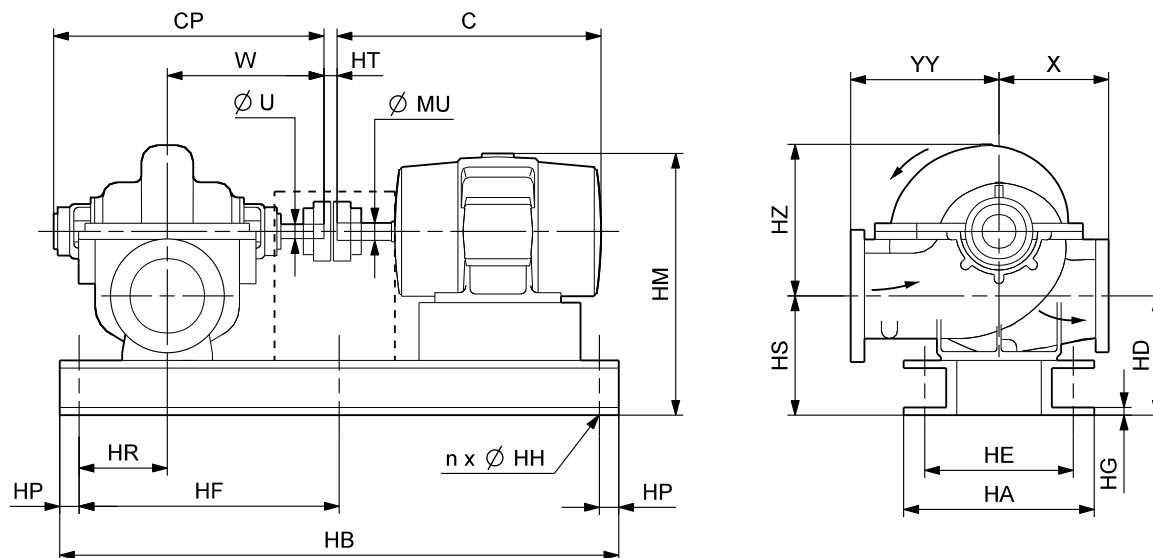

TMD04 1828 1108

Dimensions

Motor			Pump dimensions [mm]									Motor dimensions [mm]			Distance between shaft ends [mm]
P ₂ [kW]	Frame size	Number of poles	CP		W	ØU	X	YY	HD	HS	HZ	C	HM	ØMU	HT
			Mechanical seal	Stuffing box											
18.5	180MC	4	631	674	368	38.10	357	357	329	329	470	672	741	48	9.8
22	180LC	4	631	674	368	38.10	357	357	329	329	470	710	741	48	9.8
30	200LC	4	631	674	368	38.10	357	357	379	379	470	775	819	55	13
37	225SC	4	631	674	368	38.10	357	357	379	379	470	816	849	60	25.7
45	225MC	4	631	674	368	38.10	357	357	379	379	470	841	849	60	25.7
55	250SC	4	631	674	368	38.10	357	357	379	379	470	883	875	70	38.4
75	250MC	4	631	674	368	38.10	357	357	379	379	470	921	875	70	38.4
90	280SB	4	631	674	368	38.10	357	357	379	379	470	1026	930	80	38.4
110	280MB	4	631	674	368	38.10	357	357	379	379	470	1077	930	80	38.4

Motor			Base frame dimensions [mm]									Overhang [mm]			Net weights [kg]			Shipping volume [m ³]
P ₂ [kW]	Frame size	Number of poles	HB	HP	HR	HF	HA	HE	HG	n	ØHH	Pump end		Motor end	Pump	Motor	Total	
												Mechanical seal	Stuffing box					
18.5	180MC	4	1300	200	80	-	440	370	10	4	18	-	26	30	255	166	594	0.967
22	180LC	4	1300	200	80	-	440	370	10	4	18	-	26	68	255	205	633	0.994
30	200LC	4	1350	200	80	-	485	415	11	4	23	-	26	86	255	280	736	1.134
37	225SC	4	1400	200	80	-	535	465	11	4	23	-	26	90	255	320	789	1.262
45	225MC	4	1420	200	80	-	535	465	11	4	23	-	26	95	255	360	829	1.282
55	250SC	4	1500	200	80	550	585	515	11	6	23	-	26	69	255	510	1010	1.483
75	250MC	4	1500	200	80	550	585	515	11	6	23	-	26	107	255	565	1065	1.519
90	280SB	4	1620	200	80	610	645	575	11	6	23	-	26	93	255	680	1190	1.779
110	280MB	4	1620	200	80	610	645	575	11	6	23	-	26	144	255	760	1270	1.831

Performance curves

HS 150-125-305
4-pole

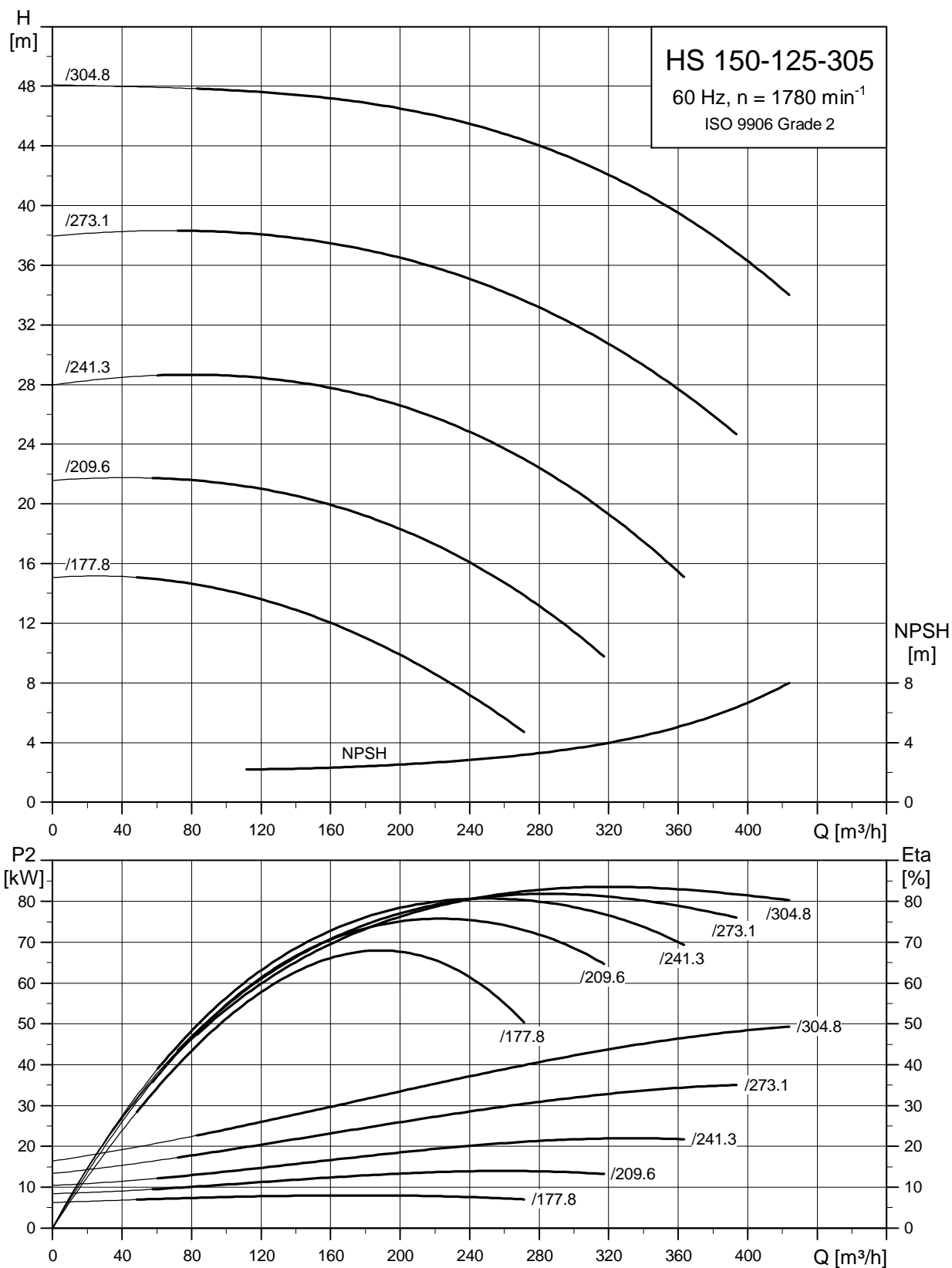

TM03 9854 4507

Dimensional sketch

HS standard, 150-125-305

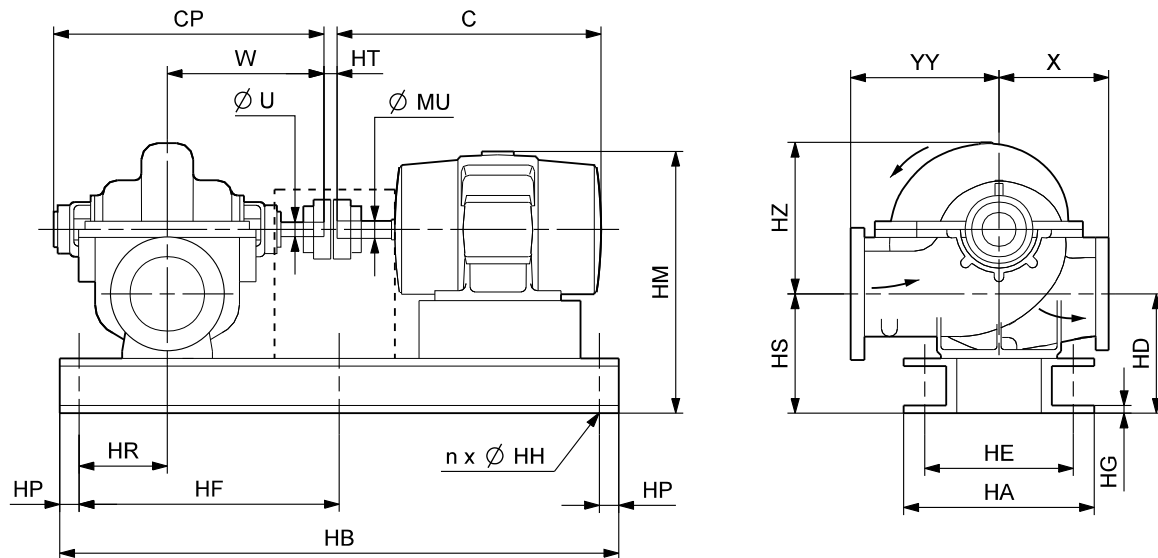

TM04 1828 1108

Dimensions

Motor			Pump dimensions [mm]									Motor dimensions [mm]			Distance between shaft ends [mm]
P ₂ [kW]	Frame size	Number of poles	CP		W	ØU	X	YY	HD	HS	HZ	C	HM	ØMU	HT
			Mechanical seal	Stuffing box											
11	160M	4	775	775	419	38.10	330	330	335	335	475	608	755	42	3.2
15	160L	4	775	775	419	38.10	330	330	335	335	475	652	755	42	3.2
18.5	180MC	4	775	775	419	38.10	330	330	335	335	475	672	779	48	9.7
22	180LC	4	775	775	419	38.10	330	330	335	335	475	710	779	48	9.7
30	200LC	4	775	775	419	38.10	330	330	385	385	475	775	857	55	12.9
37	225SC	4	775	775	419	38.10	330	330	385	385	475	816	887	60	25.6
45	225MC	4	775	775	419	38.10	330	330	385	385	475	841	887	60	25.6
55	250SC	4	775	775	419	38.10	330	330	385	385	475	883	913	70	38.3

Motor			Base frame dimensions [mm]									Overhang [mm]			Net weights [kg]			Shipping volume [m ³]
P ₂ [kW]	Frame size	Number of poles	HB	HP	HR	HF	HA	HE	HG	n	ØHH	Pump end		Motor end	Pump	Motor	Total	
												Mechanical seal	Stuffing box					
												11	160M	4	1290	200	60	-
15	160L	4	1290	200	60	-	435	355	10	4	18	96	96	44	268	158	591	0.957
18.5	180MC	4	1340	200	60	-	450	380	10	4	18	96	96	21	268	166	620	0.974
22	180LC	4	1340	200	60	-	450	380	10	4	18	96	96	59	268	205	659	1.000
30	200LC	4	1380	200	60	-	485	415	11	4	23	96	96	87	268	280	759	1.183
37	225SC	4	1430	200	60	-	535	465	11	4	23	96	96	91	268	320	812	1.358
45	225MC	4	1450	200	60	-	535	465	11	4	23	96	96	96	268	360	857	1.379
55	250SC	4	1490	200	60	-	585	515	11	4	23	96	96	110	268	510	1029	1.594

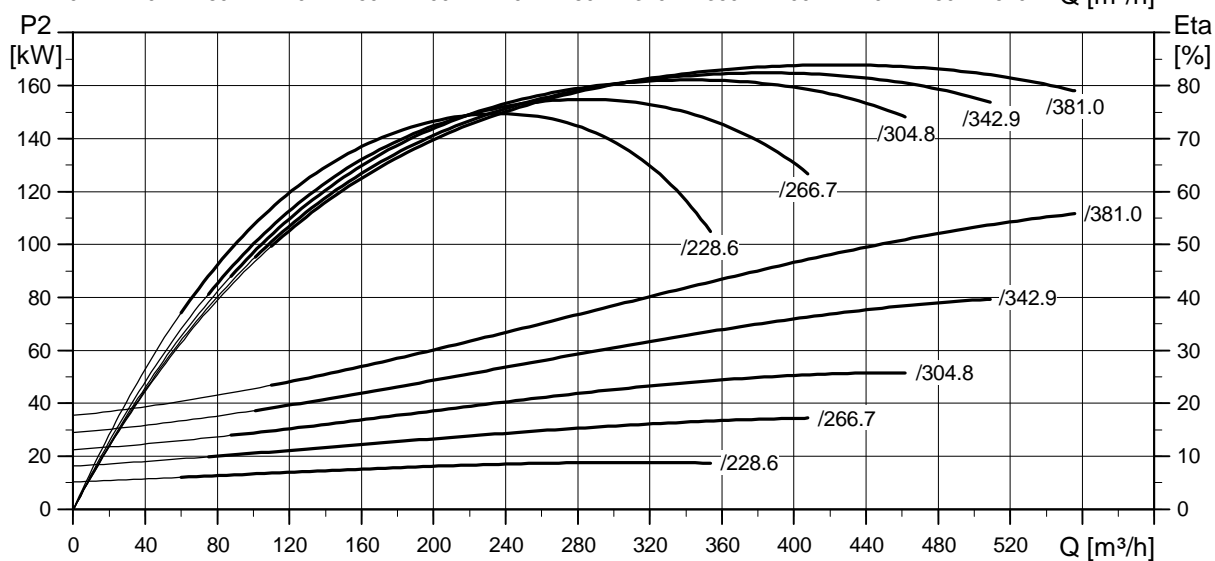
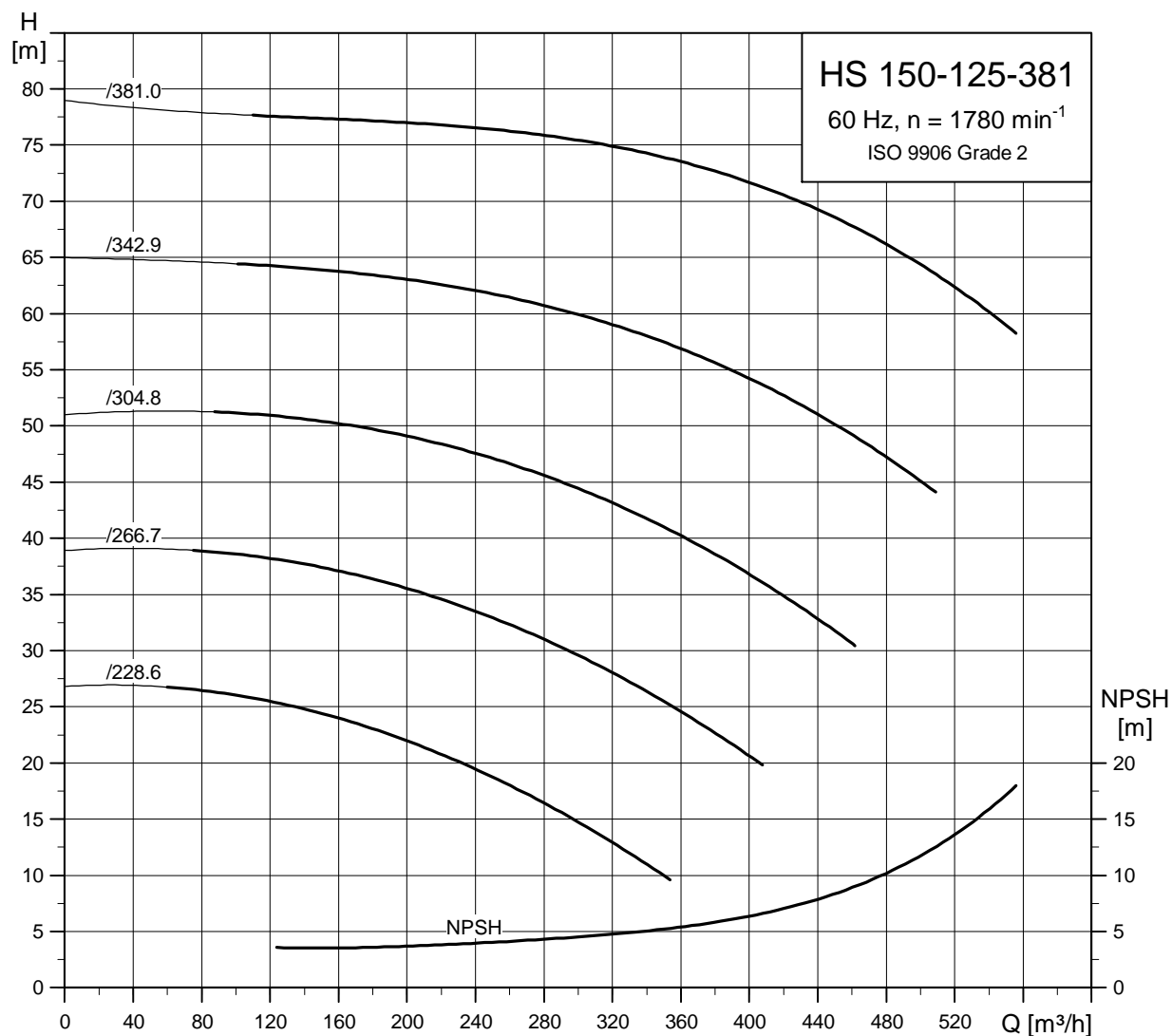

TM03 9855 4507

Dimensional sketch

HS standard, 150-125-381

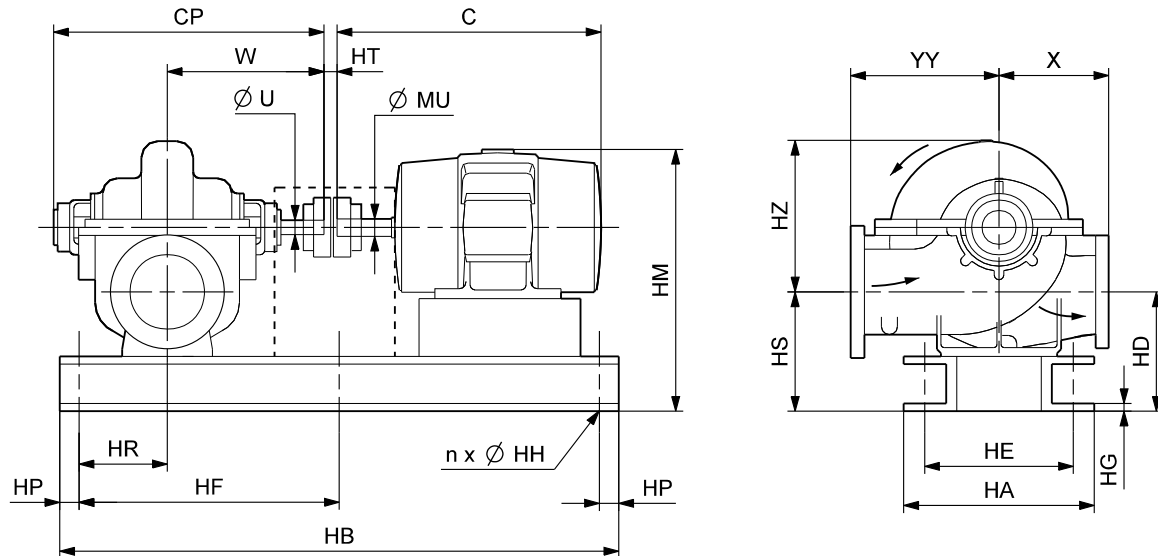

TMD04 1828 1108

Dimensions

Motor			Pump dimensions [mm]									Motor dimensions [mm]			Distance between shaft ends [mm]
P ₂ [kW]	Frame size	Number of poles	CP		W	Ø U	X	YY	HD	HS	HZ	C	HM	Ø MU	HT
			Mechanical seal	Stuffing box											
22	180LC	4	801	801	432	38.10	356	381	335	335	550	710	821	48	9.8
30	200LC	4	801	801	432	38.10	356	381	385	385	550	775	899	55	13
37	225SC	4	801	801	432	38.10	356	381	385	385	550	816	929	60	25.7
45	225MC	4	801	801	432	38.10	356	381	385	385	550	841	929	60	25.7
55	250SC	4	801	801	432	38.10	356	381	385	385	550	883	955	70	38.4
75	250MC	4	801	801	432	38.10	356	381	385	385	550	921	955	70	38.4
90	280SB	4	801	801	432	38.10	356	381	385	385	550	1026	1010	80	38.4
110	280MB	4	801	801	432	38.10	356	381	385	385	550	1077	1010	80	38.4
132	315SB	4	801	801	432	38.10	356	381	385	385	550	1116	1058	85	47.9

Motor			Base frame dimensions [mm]									Overhang [mm]			Net weights [kg]			Shipping volume [m ³]
P ₂ [kW]	Frame size	Number of poles	HB	HP	HR	HF	HA	HE	HG	n	Ø HH	Pump end		Motor end	Pump	Motor	Total	
												Mechanical seal	Stuffing box					
22	180LC	4	1350	200	60	-	440	380	10	4	18	109	109	62	318	205	722	1.282
30	200LC	4	1400	200	60	-	485	415	11	4	23	109	109	79	318	280	819	1.415
37	225SC	4	1440	200	60	-	535	465	11	4	23	109	109	93	318	320	872	1.551
45	225MC	4	1470	200	60	-	535	465	11	4	23	109	109	88	318	360	917	1.575
55	250SC	4	1540	200	60	570	585	515	11	6	23	109	109	73	318	510	1094	1.796
75	250MC	4	1540	200	60	570	585	515	11	6	23	109	109	111	318	565	1149	1.835
90	280SB	4	1670	200	60	635	645	575	11	6	23	109	109	86	318	680	1284	2.128
110	280MB	4	1670	200	60	635	645	575	11	6	23	109	109	137	318	760	1364	2.186
132	315SB	4	1690	200	60	645	720	650	11	6	23	109	109	166	318	930	1566	2.413

Performance curves

HS 200-150-305A
4-pole

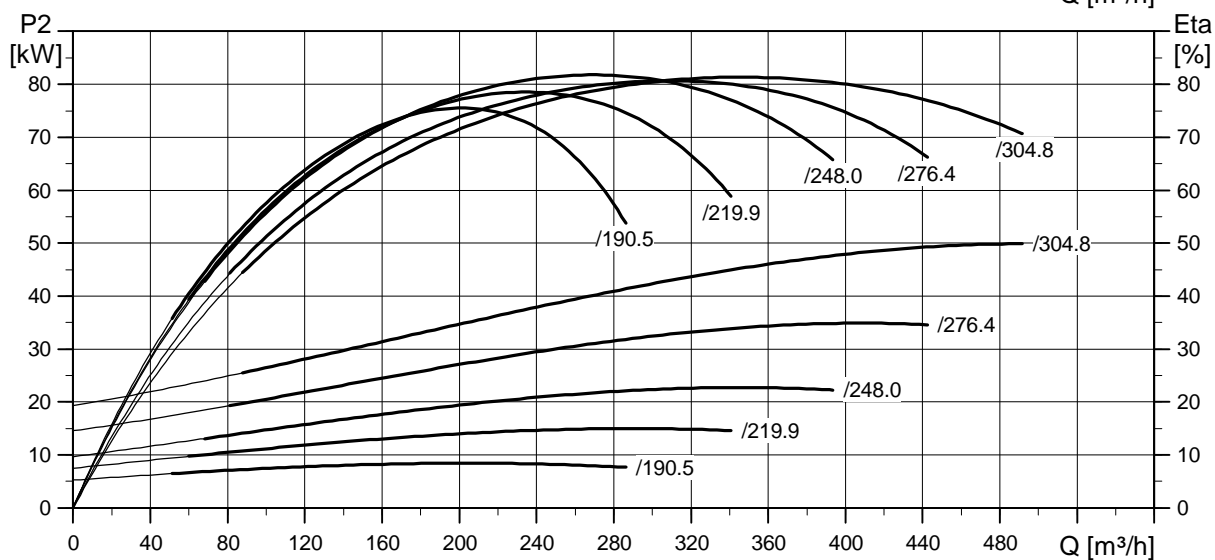
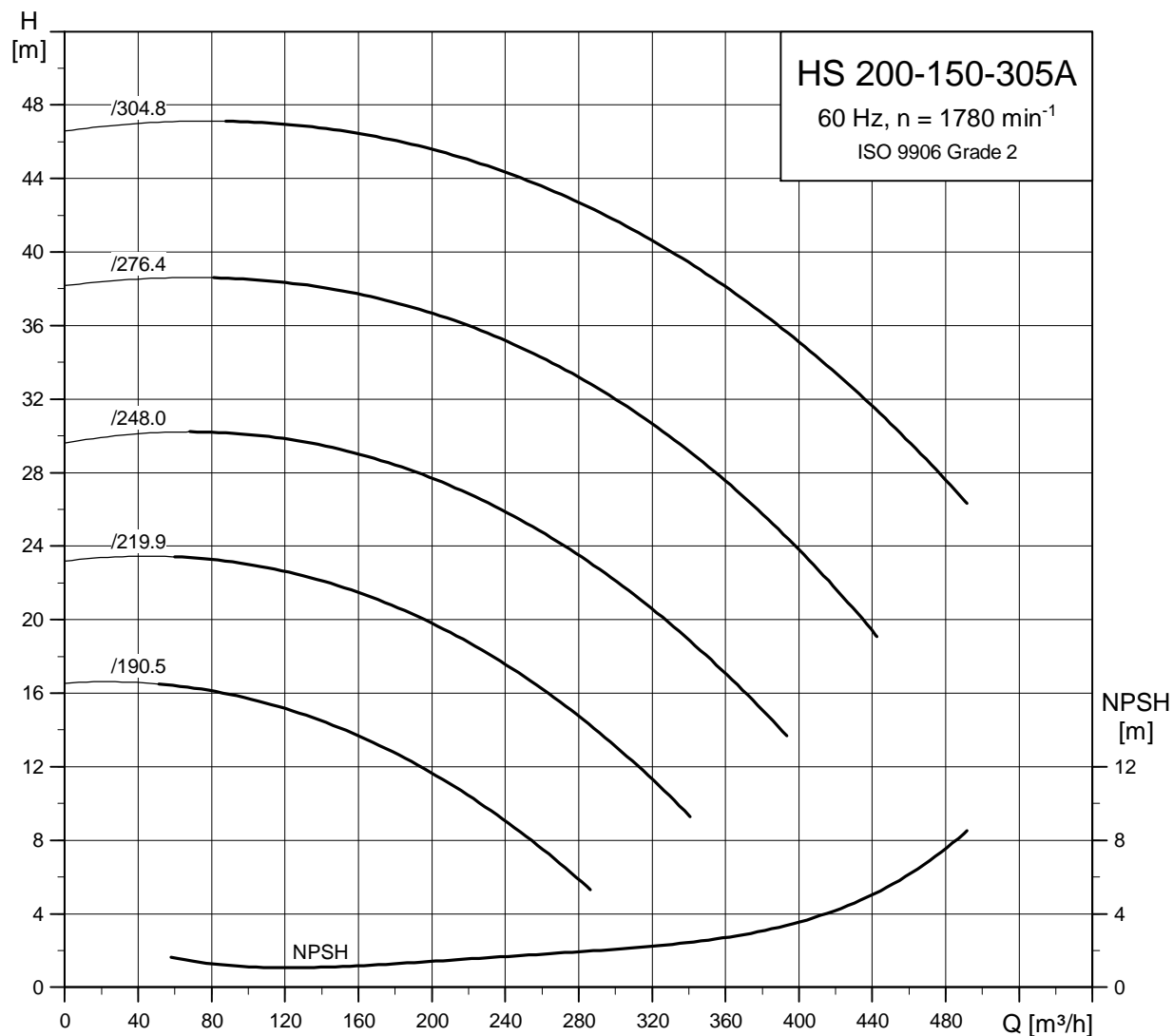

TM03 9856 4507

Dimensional sketch

HS standard, 200-150-305A

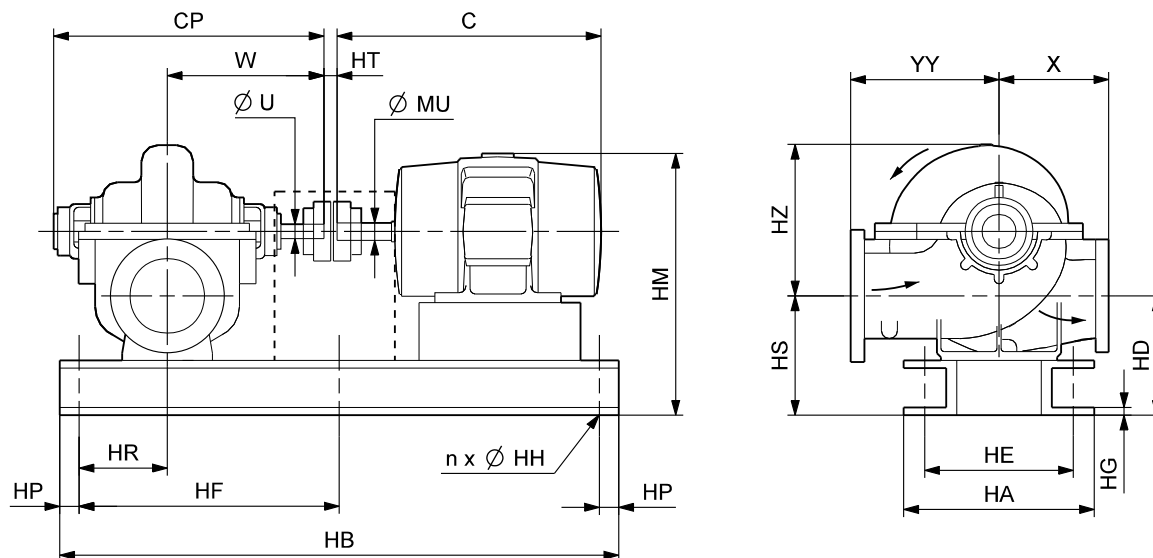

TMD04 1828 1108

Dimensions

Motor			Pump dimensions [mm]									Motor dimensions [mm]			Distance between shaft ends [mm]
P ₂ [kW]	Frame size	Number of poles	CP		W	ØU	X	YY	HD	HS	HZ	C	HM	ØMU	HT
			Mechanical seal	Stuffing box											
11	160M	4	656	699	381	38.10	279	330	361	361	430	608	743	42	3.2
15	160L	4	656	699	381	38.10	279	330	361	361	430	652	743	42	3.2
18.5	180MC	4	656	699	381	38.10	279	330	361	361	430	672	767	48	9.8
22	180LC	4	656	699	381	38.10	279	330	361	361	430	710	767	48	9.8
30	200LC	4	656	699	381	38.10	279	330	411	411	430	775	845	55	13
37	225SC	4	656	699	381	38.10	279	330	411	411	430	816	875	60	25.7
45	225MC	4	656	699	381	38.10	279	330	411	411	430	841	875	60	25.7
55	250SC	4	656	699	381	38.10	279	330	411	411	430	883	901	70	38.4
75	250MC	4	656	699	381	38.10	279	330	411	411	430	921	901	70	38.4

Motor			Base frame dimensions [mm]								Overhang [mm]			Net weights [kg]			Shipping volume [m ³]	
P ₂ [kW]	Frame size	Number of poles	HB	HP	HR	HF	HA	HE	HG	n	ØHH	Pump end		Motor end	Pump	Motor		Total
												Mechanical seal	Stuffing box					
11	160M	4	1250	200	60	-	445	365	10	4	18	15	58	2	255	130	542	0.856
15	160L	4	1250	200	60	-	445	365	10	4	18	15	58	46	255	158	570	0.885
18.5	180MC	4	1300	200	60	-	440	380	10	4	18	15	58	23	255	166	590	0.902
22	180LC	4	1300	200	60	-	440	380	10	4	18	15	58	61	255	205	629	0.927
30	200LC	4	1350	200	60	-	485	415	11	4	23	15	58	78	255	280	736	1.106
37	225SC	4	1390	200	60	-	535	465	11	4	23	15	58	93	255	320	784	1.277
45	225MC	4	1410	200	60	-	535	465	11	4	23	15	58	98	255	360	829	1.298
55	250SC	4	1490	200	60	-	585	515	11	4	23	15	58	72	255	510	1005	1.503
75	250MC	4	1490	200	60	-	585	515	11	4	23	15	58	110	255	565	1060	1.538

Performance curves

HS 200-150-305C
4-pole

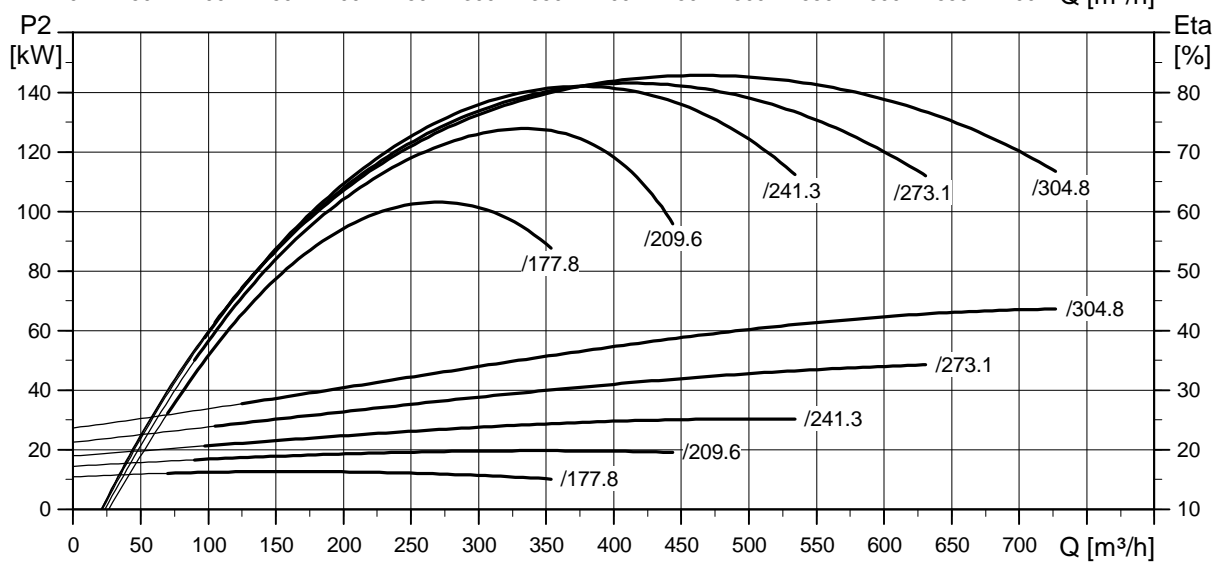
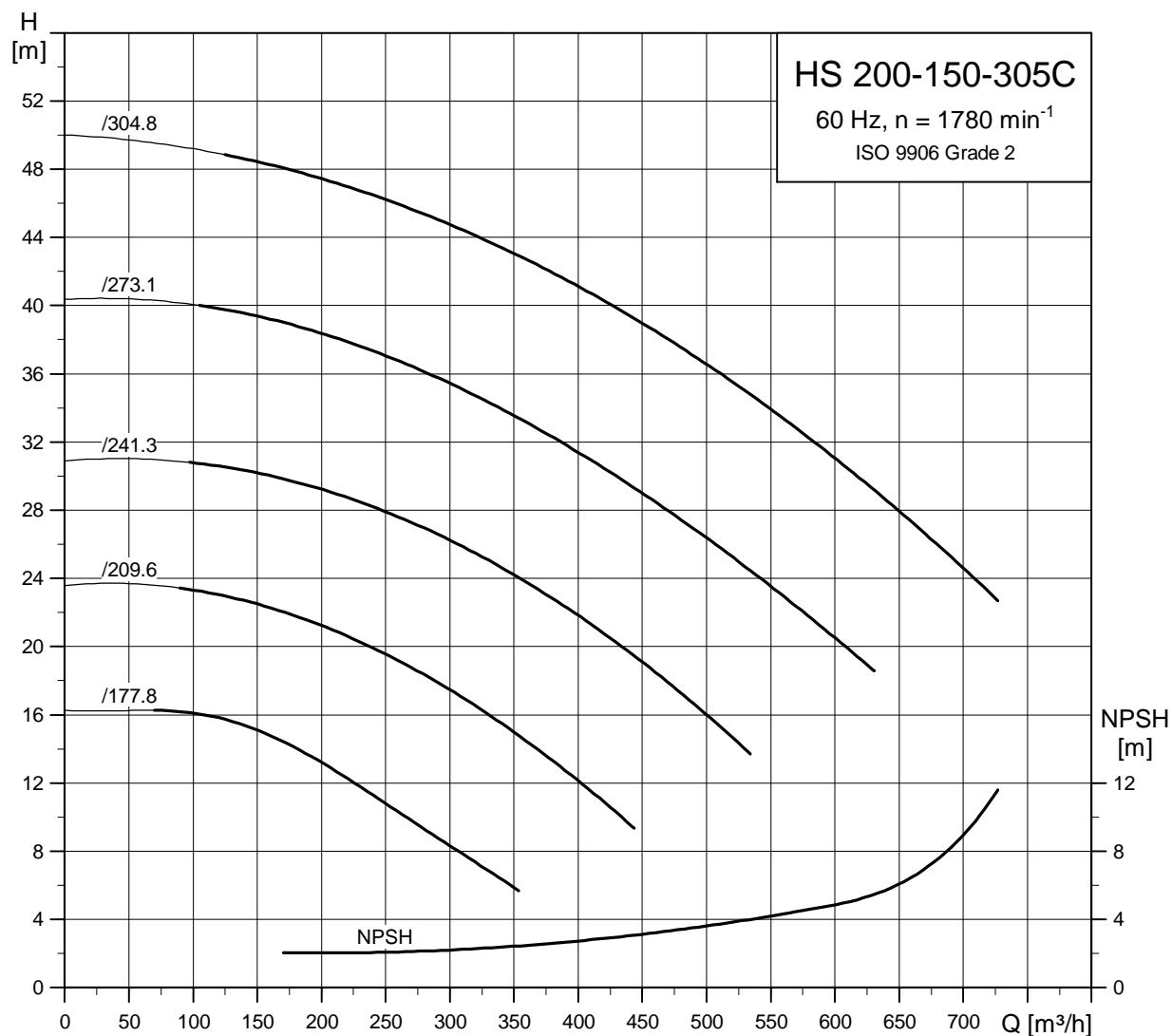

TM03 9857 450

Dimensional sketch

HS standard, 200-150-305C

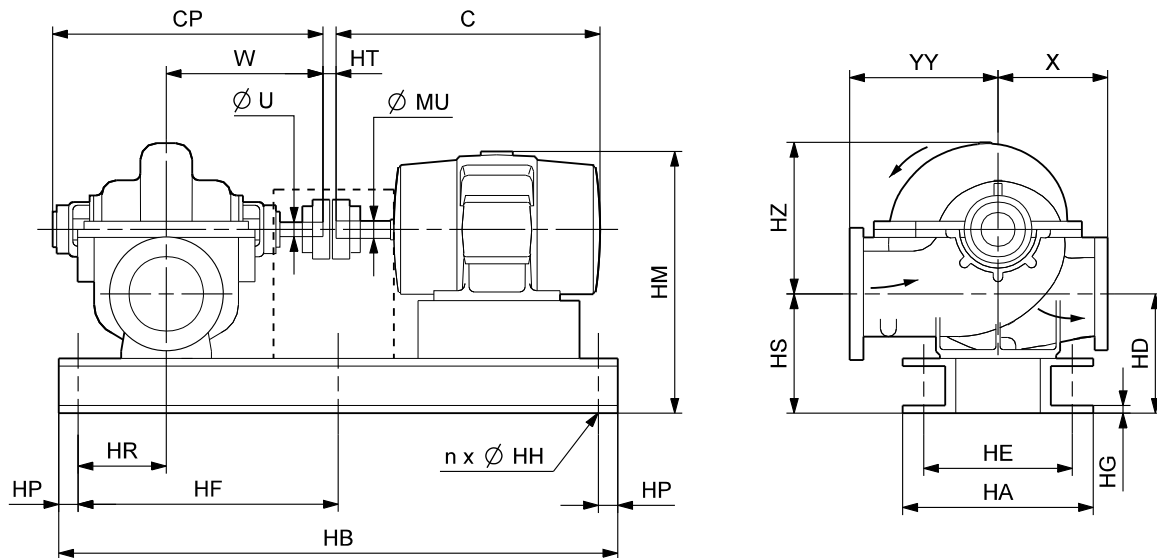

TMD04 1828 1108

Dimensions

Motor			Pump dimensions [mm]									Motor dimensions [mm]			Distance between shaft ends [mm]
P ₂ [kW]	Frame size	Number of poles	CP		W	ØU	X	YY	HD	HS	HZ	C	HM	ØMU	HT
			Mechanical seal	Stuffing box											
15	160L	4	801	801	432	38.10	356	406	335	335	530	652	793	42	3.2
18.5	180MC	4	801	801	432	38.10	356	406	335	335	530	672	817	48	9.7
22	180LC	4	801	801	432	38.10	356	406	335	335	530	710	817	48	9.7
30	200LC	4	801	801	432	38.10	356	406	385	385	530	775	895	55	12.9
37	225SC	4	801	801	432	38.10	356	406	385	385	530	816	925	60	25.6
45	225MC	4	801	801	432	38.10	356	406	385	385	530	841	925	60	25.6
55	250SC	4	801	801	432	38.10	356	406	385	385	530	883	951	70	38.3
75	250MC	4	801	801	432	38.10	356	406	385	385	530	921	951	70	38.3

Motor			Base frame dimensions [mm]									Overhang [mm]			Net weights [kg]			Shipping volume [m ³]
P ₂ [kW]	Frame size	Number of poles	HB	HP	HR	HF	HA	HE	HG	n	ØHH	Pump end		Motor end	Pump	Motor	Total	
												Mechanical seal	Stuffing box					
												15	160L	4	1300	200	60	-
18.5	180MC	4	1350	200	60	-	480	420	10	4	18	109	109	24	411	166	771	1.303
22	180LC	4	1350	200	60	-	480	420	10	4	18	109	109	62	411	205	810	1.336
30	200LC	4	1400	200	60	-	525	450	11	4	23	109	109	79	411	280	922	1.477
37	225SC	4	1440	200	60	-	535	465	11	4	23	109	109	93	411	320	965	1.583
45	225MC	4	1460	200	60	-	535	465	11	4	23	109	109	98	411	360	1010	1.608
55	250SC	4	1540	200	60	570	585	515	11	6	23	109	109	73	411	510	1187	1.842
75	250MC	4	1540	200	60	570	585	515	11	6	23	109	109	111	411	565	1242	1.882

Performance curves

HS 200-150-381
4-pole

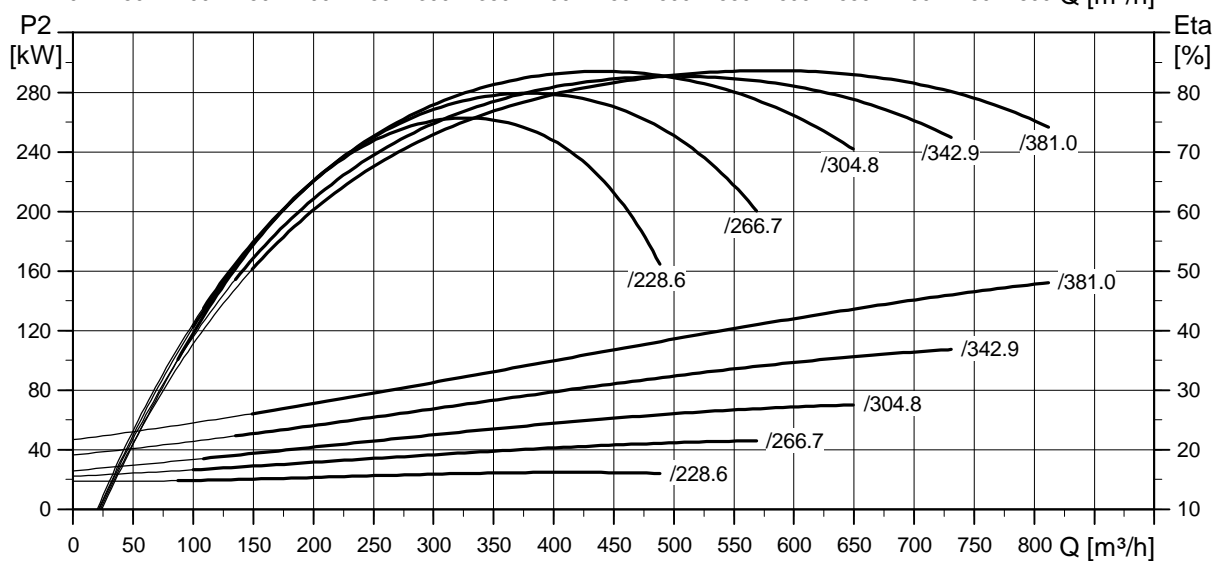
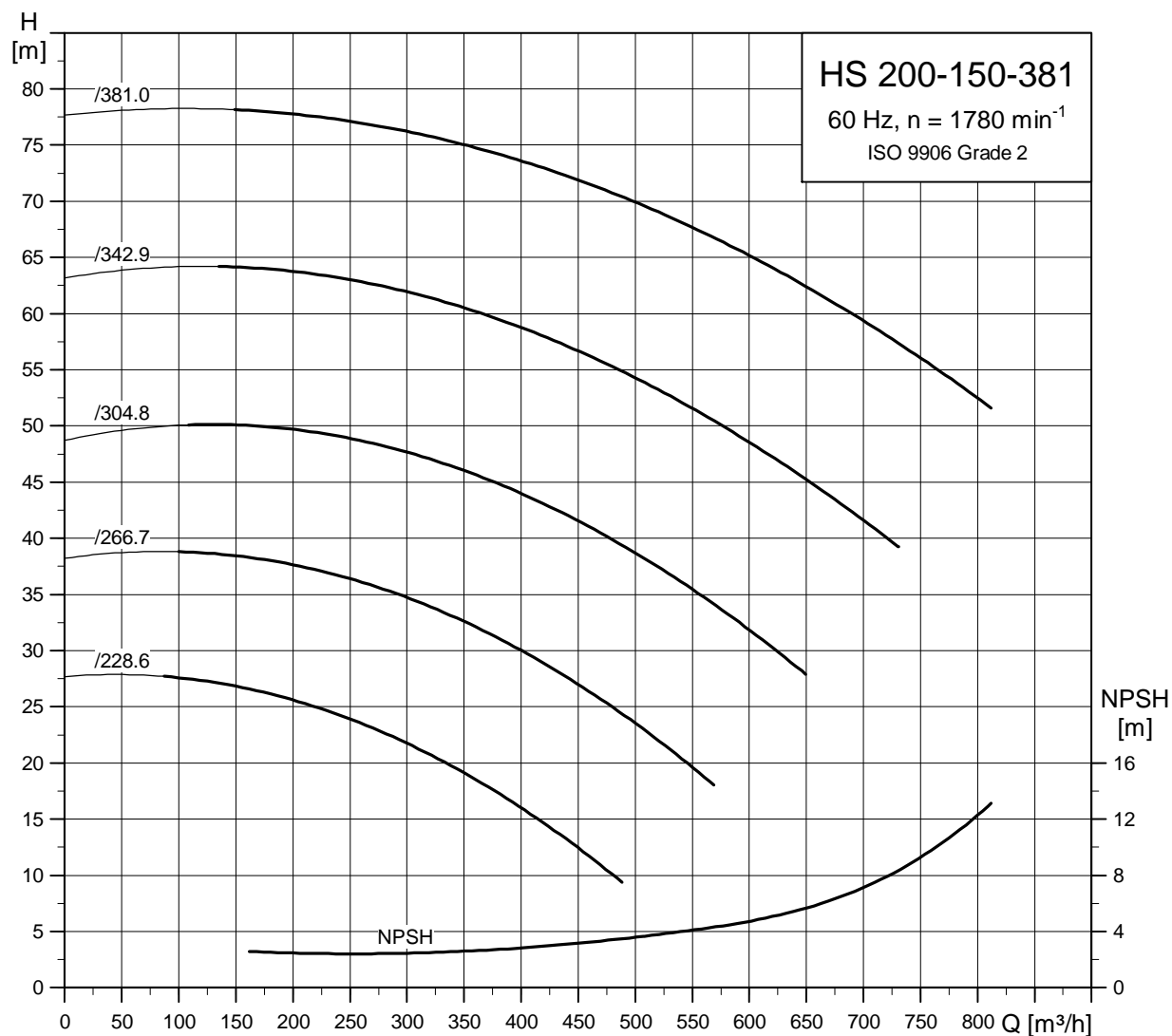

TM03 9858 4507

Dimensional sketch

HS standard, 200-150-381

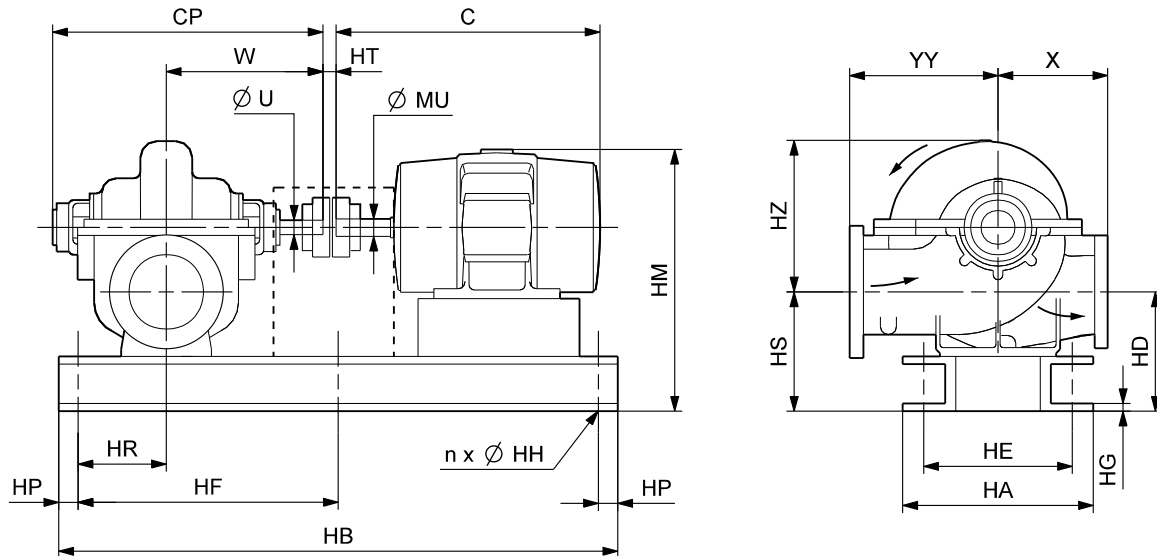

TMD04 1828 1108

Dimensions

Motor			Pump dimensions [mm]									Motor dimensions [mm]			Distance between shaft ends [mm]
P ₂ [kW]	Frame size	Number of poles	CP		W	ØU	X	YY	HD	HS	HZ	C	HM	ØMU	HT
			Mechanical seal	Stuffing box											
30	200LC	4	929	929	508	44.45	381	406	404	404	605	775	953	55	3.2
37	225SC	4	929	929	508	44.45	381	406	404	404	605	816	983	60	3.2
45	225MC	4	929	929	508	44.45	381	406	404	404	605	841	983	60	3.2
55	250SC	4	929	929	508	44.45	381	406	404	404	605	883	1009	70	14.6
75	250MC	4	929	929	508	44.45	381	406	404	404	605	921	1009	70	14.6
90	280SB	4	929	929	508	44.45	381	406	404	404	605	1026	1064	80	14.6
110	280MB	4	929	929	508	44.45	381	406	404	404	605	1077	1064	80	14.6
132	315SB	4	929	929	508	44.45	381	406	404	404	605	1116	1112	85	24.1
160	315MB	4	929	929	508	44.45	381	406	404	404	605	1167	1112	85	24.1
200	315MB	4	929	929	508	44.45	381	406	404	404	605	1167	1112	85	24.1

Motor			Base frame dimensions [mm]									Overhang [mm]			Net weights [kg]			Shipping volume [m ³]
P ₂ [kW]	Frame size	Number of poles	HB	HP	HR	HF	HA	HE	HG	n	ØHH	Pump end		Motor end	Pump	Motor	Total	
												Mechanical seal	Stuffing box					
												30	200LC	4	1530	200	130	565
37	225SC	4	1560	200	130	580	535	465	11	6	23	91	91	97	455	320	1029	1.838
45	225MC	4	1590	200	130	595	535	460	11	6	23	91	91	92	455	360	1079	1.865
55	250SC	4	1660	200	130	630	585	515	11	6	23	91	91	75	455	510	1260	2.072
75	250MC	4	1660	200	130	630	585	515	11	6	23	91	91	113	455	565	1315	2.115
90	280SB	4	1790	200	130	695	645	575	11	6	23	91	91	89	455	680	1450	2.434
110	280MB	4	1790	200	130	695	645	575	11	6	23	91	91	140	455	760	1530	2.497
132	315SB	4	1870	200	130	735	720	650	11	6	23	91	91	108	455	930	1727	2.744
160	315MB	4	1870	200	130	735	720	650	11	6	23	91	91	159	455	1020	1817	2.812
200	315MB	4	1870	200	130	735	720	650	11	6	23	91	91	159	455	1270	2067	2.812

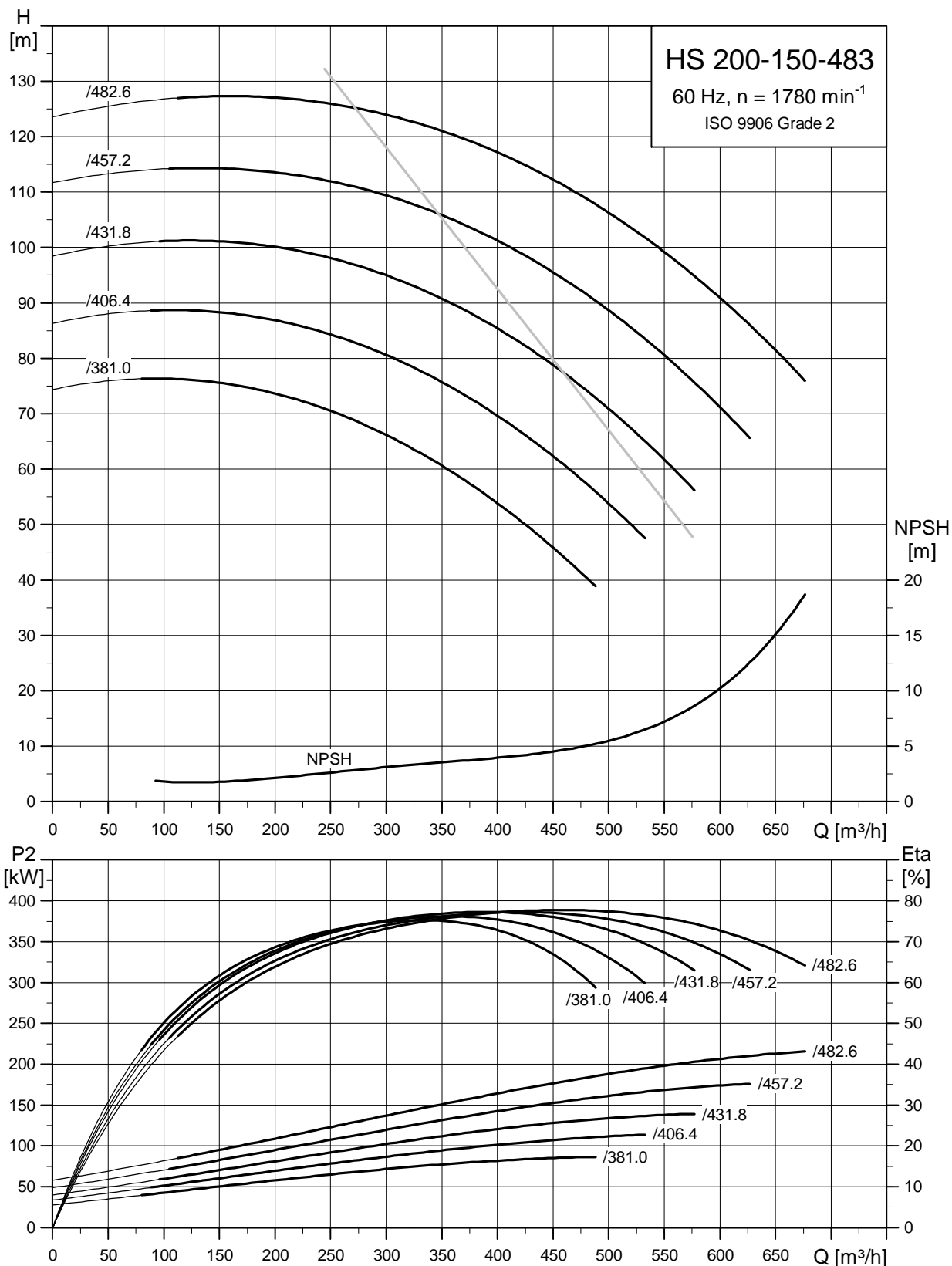

TM03 9859 4507

The grey line represents a maximum shaft load of 7.25 kW/100 rpm for a $\varnothing 44.5$ (1.75 inch) pump shaft when pumping water at the conditions mentioned on page 39. If the required shaft load exceeds 7.25 kW/100 rpm, use a pump with a $\varnothing 50.8$ (2 inch) pump shaft.

Be aware that the curves will change when pumping liquids with a higher density and/or viscosity than water.

Dimensional sketch

HS standard, 200-150-483

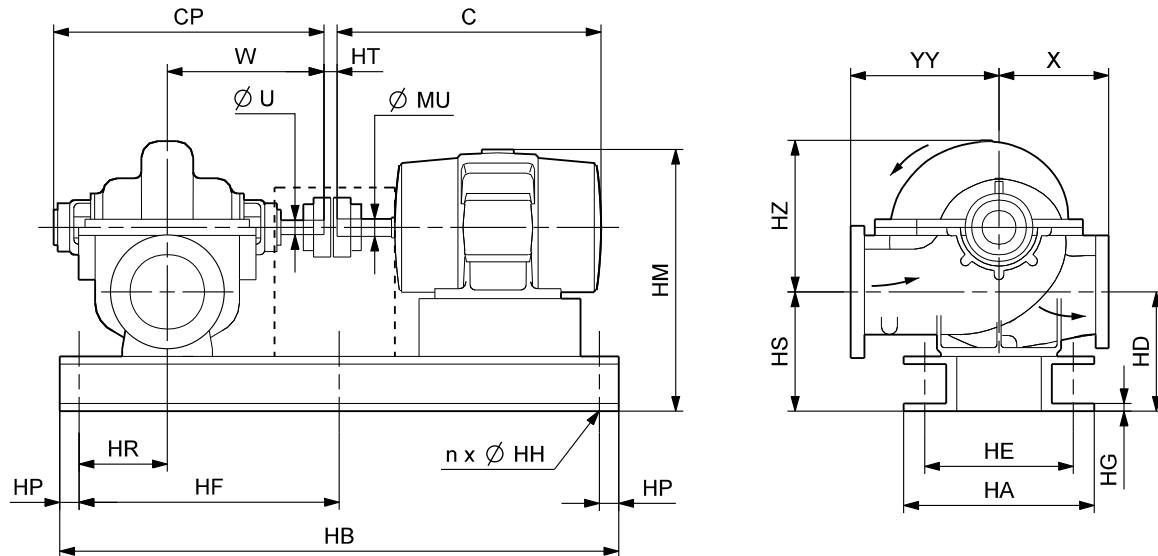

TM04 1828 1108

Dimensions

Motor			Pump dimensions [mm]									Motor dimensions [mm]			Distance between shaft ends [mm]
P ₂ [kW]	Frame size	Number of poles	CP		W	ØU	X	YY	HD	HS	HZ	C	HM	ØMU	HT
			Mechanical seal	Stuffing box											
90	280SB	4	888	888	489	44.45	432	432	391	391	615	1026	1032	80	11.5
110	280MB	4	888	888	489	44.45	432	432	391	391	615	1077	1032	80	11.5
132	315SB	4	899	899	489	50.80	432	432	391	391	615	1116	1080	85	25.7
160	315MB	4	899	899	489	50.80	432	432	391	391	615	1167	1080	85	25.7
200	315MB	4	899	899	489	50.80	432	432	391	391	615	1167	1080	85	25.7
250	315CB	4	899	899	489	50.80	432	432	391	391	615	1646	1211	95	25.7

Motor			Base frame dimensions [mm]										Overhang [mm]			Net weights [kg]			Shipping volume [m ³]
P ₂ [kW]	Frame size	Number of poles	HB	HP	HR	HF	HA	HE	HG	n	ØHH	Pump end		Motor end	Pump	Motor	Total		
												Mechanical seal	Stuffing box						
												90	280SB	4	1720	200	80	660	645
110	280MB	4	1720	200	80	660	645	575	11	6	23	119	119	137	534	760	1595	2.434	
132	315SB	4	1800	200	80	700	720	650	11	6	23	130	130	111	534	930	1792	2.699	
160	315MB	4	1800	200	80	700	720	650	11	6	23	130	130	162	534	1020	1882	2.767	
200	315MB	4	1800	200	80	700	720	650	11	6	23	130	130	162	534	1270	2132	2.767	
250	315CB	4	2100	200	80	850	735	665	11	6	23	130	130	341	534	1600	2522	4.272	

Performance curves

HS 200-150-508
4-pole

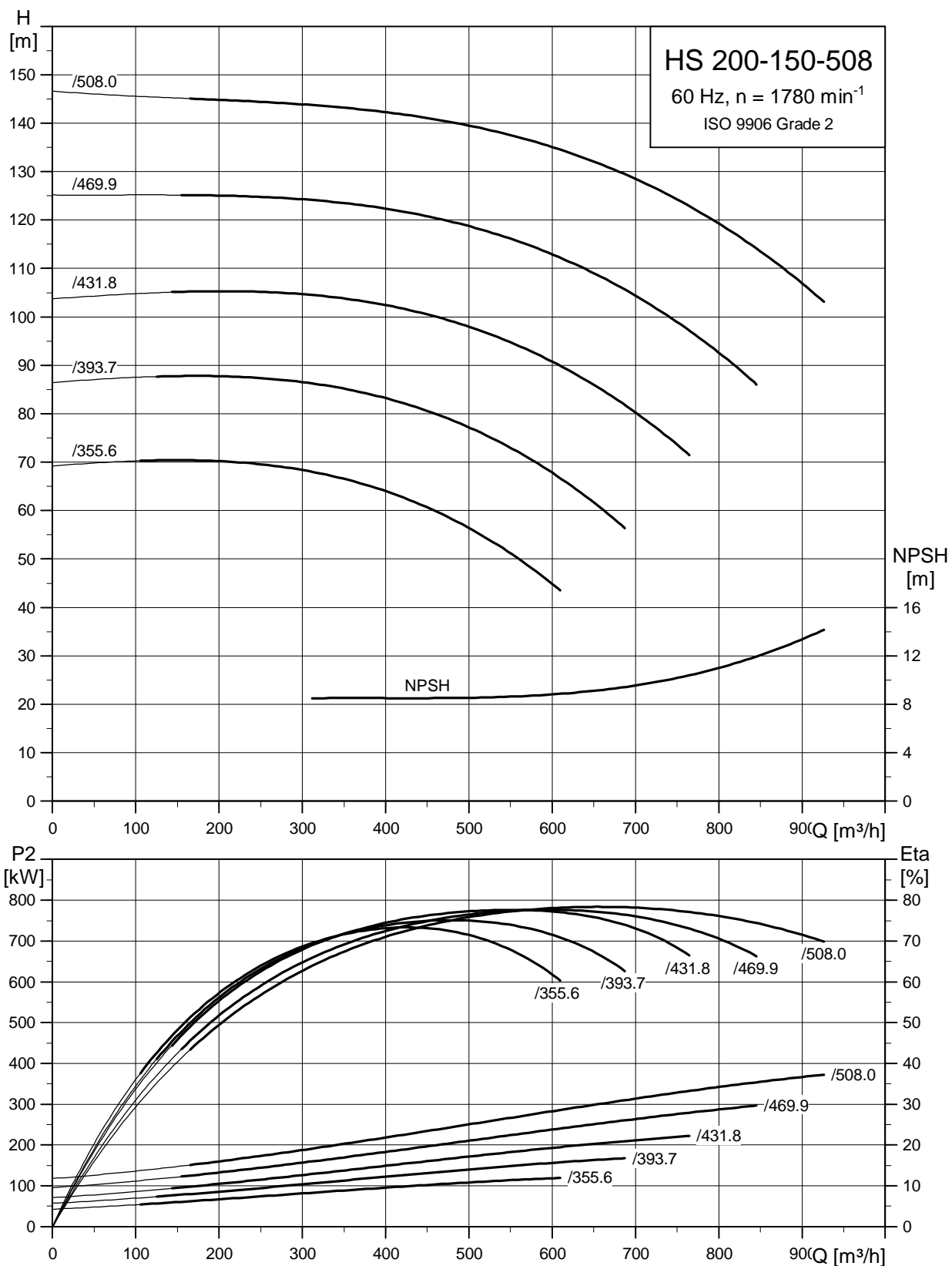

TM03 9861 450

Dimensional sketch

HS standard, 200-150-508

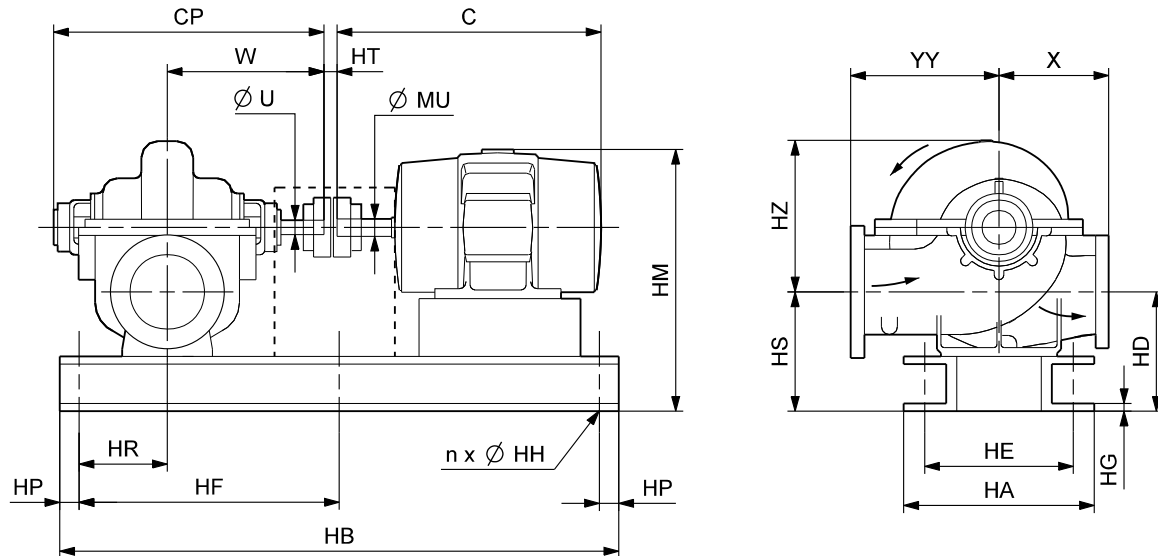

TMD04 1828 1108

Dimensions

Motor			Pump dimensions [mm]									Motor dimensions [mm]			Distance between shaft ends [mm]
P ₂ [kW]	Frame size	Number of poles	CP		W	Ø U	X	YY	HD	HS	HZ	C	HM	Ø MU	HT
			Mechanical seal	Stuffing box											
110	280MB	4	995	995	546	53.98	432	483	391	391	660	1077	1051	80	3.5
132	315SB	4	995	995	546	53.98	432	483	391	391	660	1116	1099	85	13
160	315MB	4	995	995	546	53.98	432	483	391	391	660	1167	1099	85	13
200	315MB	4	995	995	546	53.98	432	483	391	391	660	1167	1099	85	13
250	315CB	4	995	995	546	53.98	432	483	391	391	660	1646	1230	95	13
315	315DB	4	995	995	546	53.98	432	483	391	391	660	1848	1230	95	13
335	315DB	4	995	995	546	53.98	432	483	391	391	660	1848	1230	95	13
355	355AB	4	995	995	546	53.98	432	483	391	391	660	1749	1313	95	13
375	355AB	4	995	995	546	53.98	432	483	391	391	660	1749	1313	95	13
400	355CB	4	995	995	546	53.98	432	483	391	391	660	1939	1313	95	13
450	355CB	4	995	995	546	53.98	432	483	391	391	660	1939	1313	95	13

Motor			Base frame dimensions [mm]										Overhang [mm]			Net weights [kg]			Shipping volume [m ³]
P ₂ [kW]	Frame size	Number of poles	HB	HP	HR	HF	HA	HE	HG	n	Ø HH	Pump end		Motor end	Pump	Motor	Total		
												Mechanical seal	Stuffing box						
110	280MB	4	1770	200	80	685	645	575	11	6	23	168	168	137	545	760	1616	2.743	
132	315SB	4	1840	200	80	720	720	650	11	6	23	168	168	115	545	930	1818	3.006	
160	315MB	4	1840	200	80	720	720	650	11	6	23	168	168	166	545	1020	1908	3.078	
200	315MB	4	1840	200	80	720	720	650	11	6	23	168	168	166	545	1270	2158	3.078	
250	315CB	4	2340	200	80	970	735	665	11	6	23	168	168	145	545	1600	2583	4.685	
315	315DB	4	2340	200	80	970	735	665	11	6	23	168	168	347	545	1760	2743	5.042	
335	315DB	4	2340	200	80	970	735	665	11	6	23	168	168	347	545	1950	2933	5.042	
355	355AB	4	2390	200	80	995	835	765	11	6	23	168	168	198	545	2000	3013	5.630	
375	355AB	4	2390	200	80	995	835	765	11	6	23	168	168	198	545	1950	2963	5.630	
400	355CB	4	2390	200	80	995	835	765	11	6	23	168	168	388	545	2500	3513	6.018	
450	355CB	4	2390	200	80	995	835	765	11	6	23	168	168	388	545	2500	3513	6.018	

Performance curves

HS 250-200-305
4-pole

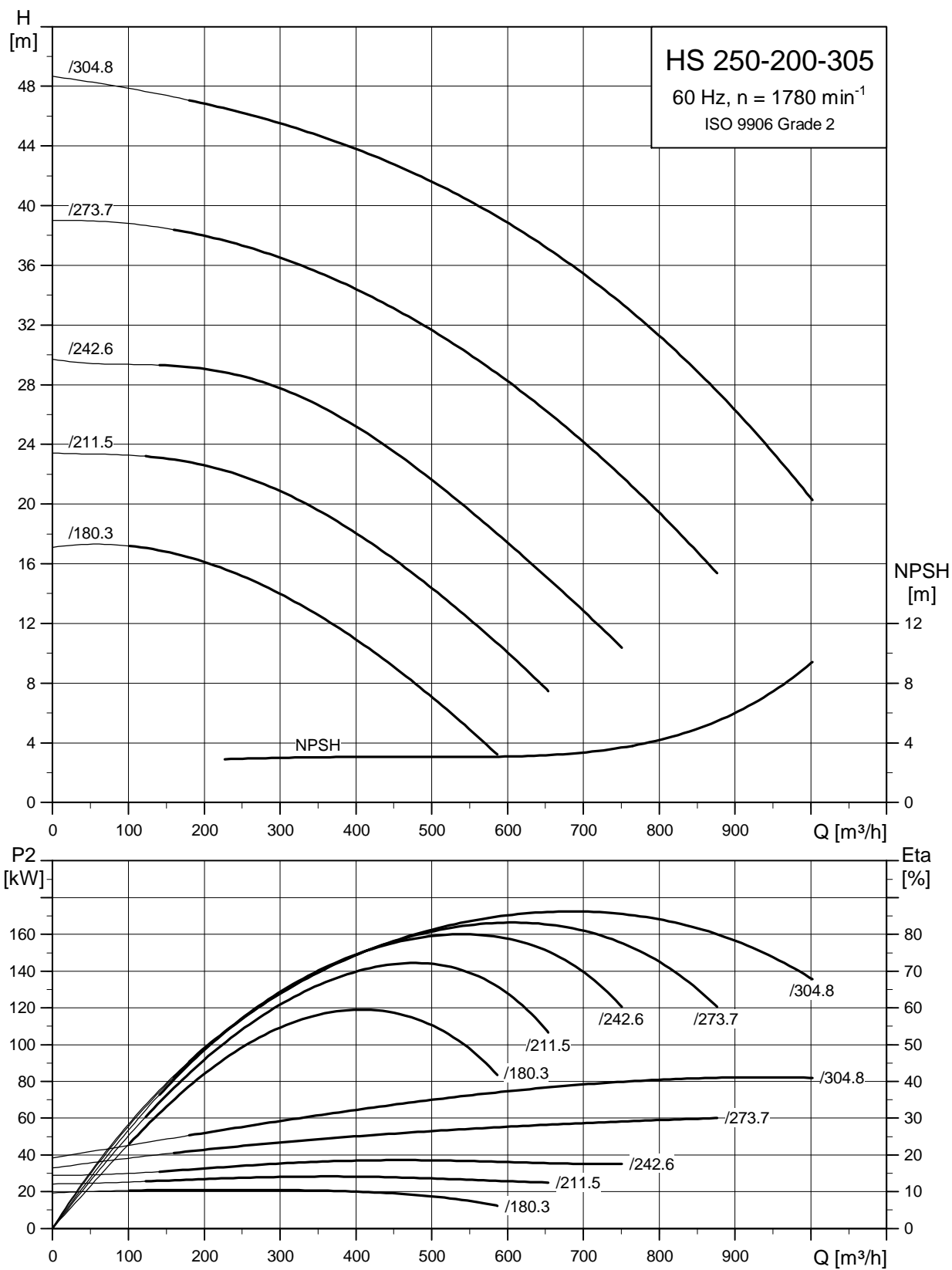

TM03 9863 4507

Dimensional sketch

HS standard, 250-200-305

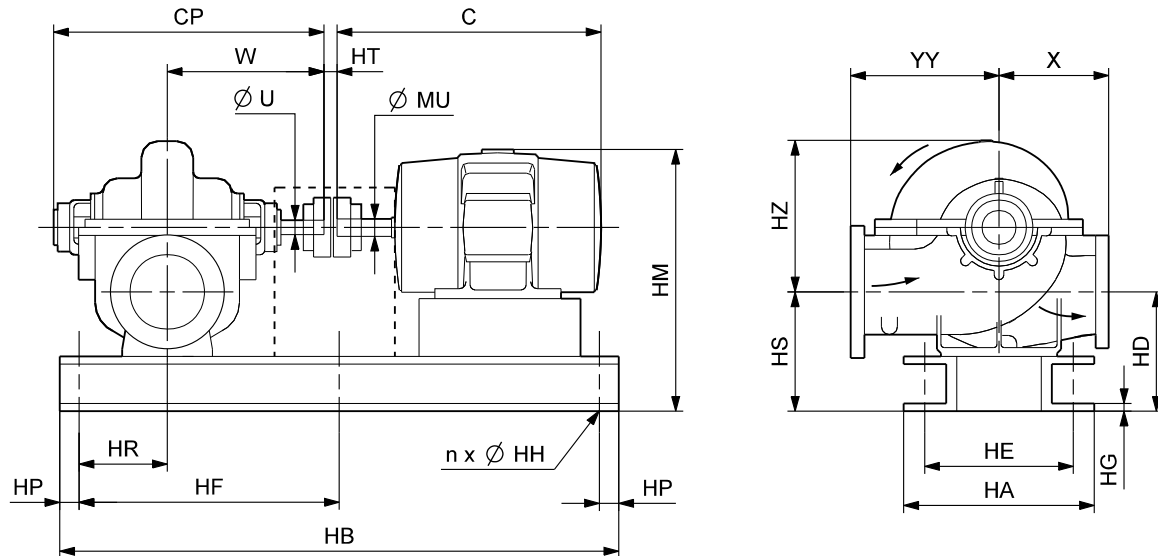

TMD4 1828 1108

Dimensions

Motor			Pump dimensions [mm]									Motor dimensions [mm]			Distance between shaft ends [mm]
P ₂ [kW]	Frame size	Number of poles	CP		W	ØU	X	YY	HD	HS	HZ	C	HM	ØMU	HT
			Mechanical seal	Stuffing box											
22	180LC	4	929	929	508	44.45	406	432	341	341	580	710	849	48	3.2
30	200LC	4	929	929	508	44.45	406	432	391	391	580	775	927	55	3.2
37	225SC	4	929	929	508	44.45	406	432	391	391	580	816	957	60	3.2
45	225MC	4	929	929	508	44.45	406	432	391	391	580	841	957	60	3.2
55	250SC	4	929	929	508	44.45	406	432	391	391	580	883	983	70	14.6
75	250MC	4	929	929	508	44.45	406	432	391	391	580	921	983	70	14.6
90	280SB	4	929	929	508	44.45	406	432	391	391	580	1026	1038	80	14.6
110	280MB	4	929	929	508	44.45	406	432	391	391	580	1077	1038	80	14.6

Motor			Base frame dimensions [mm]									Overhang [mm]			Net weights [kg]			Shipping volume [m ³]
P ₂ [kW]	Frame size	Number of poles	HB	HP	HR	HF	HA	HE	HG	n	ØHH	Pump end		Motor end	Pump	Motor	Total	
												Mechanical seal	Stuffing box					
												22	180LC	4	1460	200	100	530
30	200LC	4	1500	200	100	550	485	415	11	6	23	121	121	86	511	280	1032	1.790
37	225SC	4	1530	200	100	565	535	465	11	6	23	121	121	97	511	320	1080	1.834
45	225MC	4	1560	200	100	580	535	465	11	6	23	121	121	92	511	360	1125	1.860
55	250SC	4	1630	200	100	615	585	515	11	6	23	121	121	75	511	510	1303	2.076
75	250MC	4	1630	200	100	615	585	515	11	6	23	121	121	113	511	565	1358	2.119
90	280SB	4	1760	200	100	680	645	575	11	6	23	121	121	89	511	680	1497	2.441
110	280MB	4	1760	200	100	680	645	575	11	6	23	121	121	140	511	760	1577	2.504

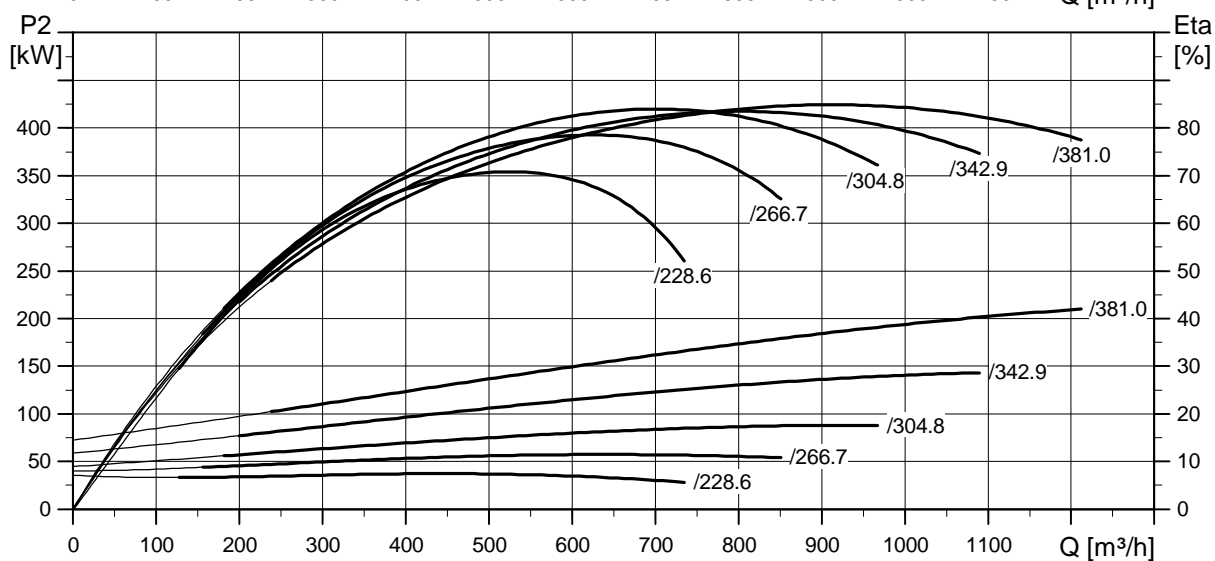
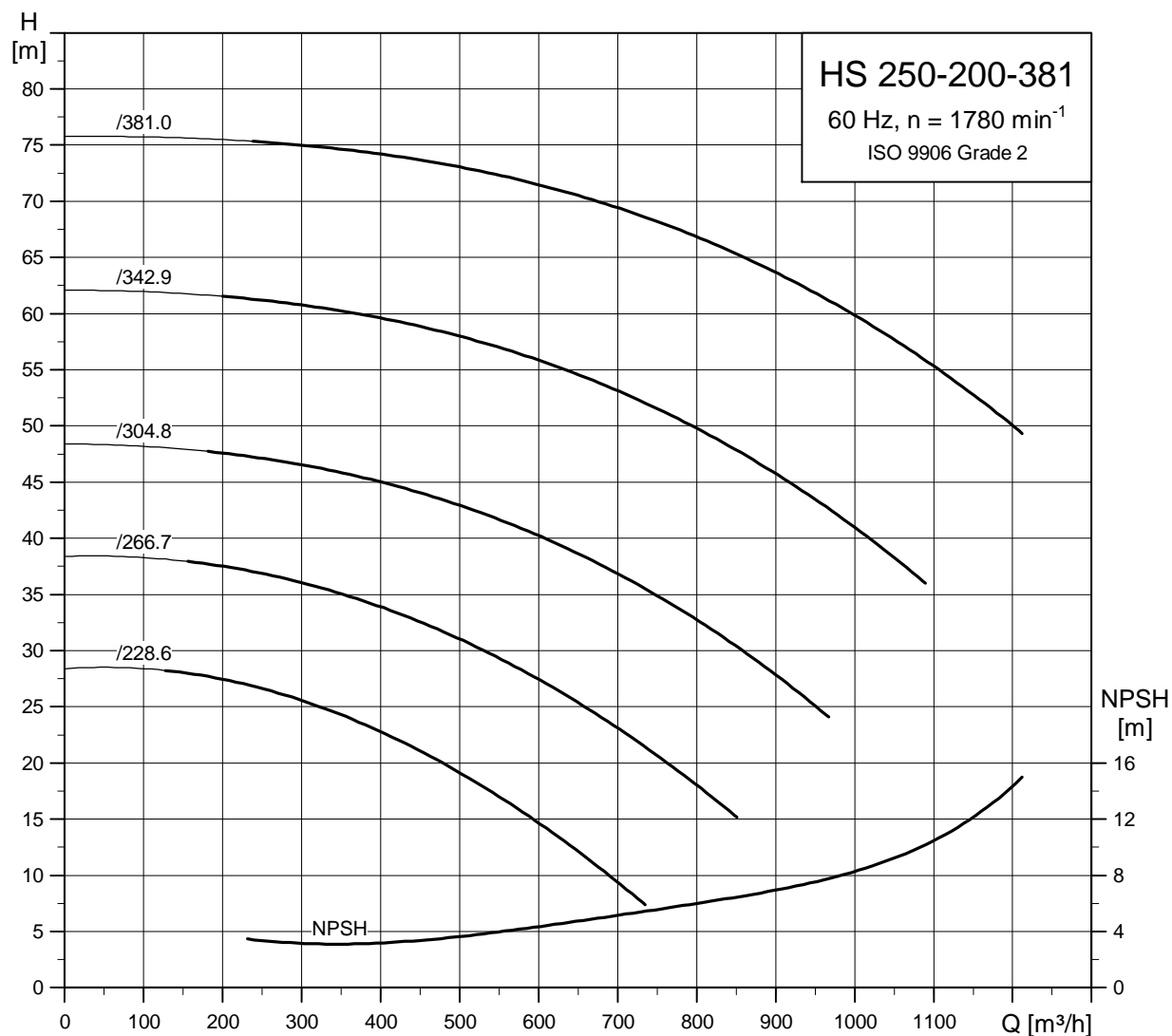

TM03 9864 4507

Dimensional sketch

HS standard, 250-200-381

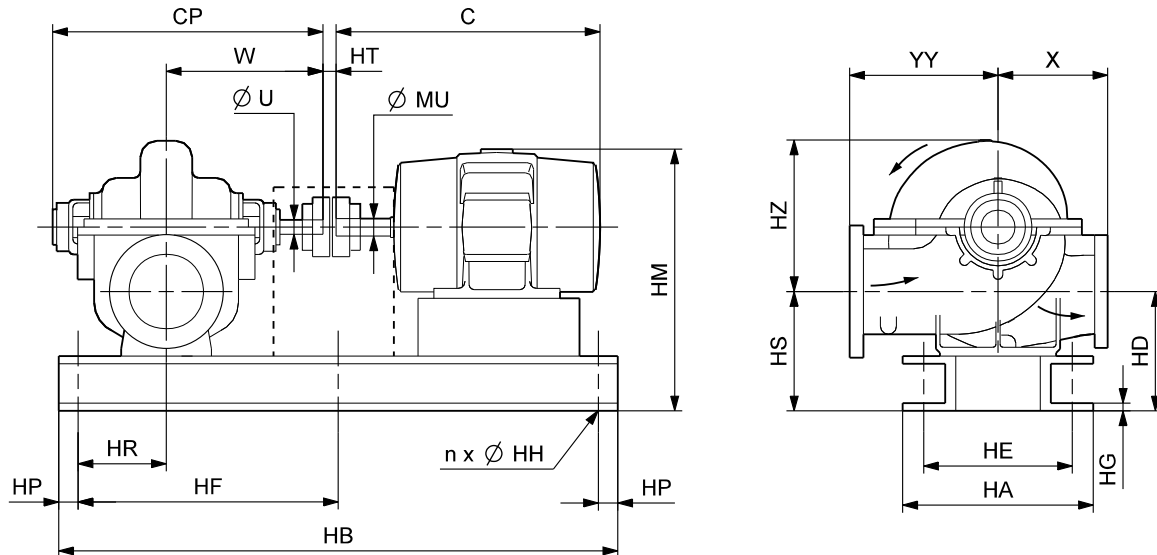

TM04 1828 1108

Dimensions

Motor			Pump dimensions [mm]									Motor dimensions [mm]			Distance between shaft ends [mm]
P ₂ [kW]	Frame size	Number of poles	CP		W	Ø U	X	YY	HD	HS	HZ	C	HM	Ø MU	HT
			Mechanical seal	Stuffing box											
45	225MC	4	949	949	518	44.45	483	483	458	458	655	841	1062	60	3.2
55	250SC	4	949	949	518	44.45	483	483	458	458	655	883	1088	70	14.5
75	250MC	4	949	949	518	44.45	483	483	458	458	655	921	1088	70	14.5
90	280SB	4	949	949	518	44.45	483	483	458	458	655	1026	1143	80	14.5
110	280MB	4	949	949	518	44.45	483	483	458	458	655	1077	1143	80	14.5
132	315SB	4	949	949	518	44.45	483	483	458	458	655	1116	1191	85	24
160	315MB	4	949	949	518	44.45	483	483	458	458	655	1167	1191	85	24
200	315MB	4	949	949	518	44.45	483	483	458	458	655	1167	1191	85	24
250	315CB	4	949	949	518	44.45	483	483	458	458	655	1646	1322	95	24

Motor			Base frame dimensions [mm]										Overhang [mm]			Net weights [kg]			Shipping volume [m ³]
P ₂ [kW]	Frame size	Number of poles	HB	HP	HR	HF	HA	HE	HG	n	Ø HH	Pump end		Motor end	Pump	Motor	Total		
												Mechanical seal	Stuffing box						
45	225MC	4	1620	200	150	610	565	465	13	6	23	81	81	92	568	360	1302	2.407	
55	250SC	4	1690	200	150	645	615	515	13	6	23	81	81	74	568	510	1484	2.505	
75	250MC	4	1690	200	150	645	615	515	13	6	23	81	81	112	568	565	1539	2.556	
90	280SB	4	1820	200	150	710	675	575	13	6	23	81	81	88	568	680	1694	2.857	
110	280MB	4	1820	200	150	710	675	575	13	6	23	81	81	139	568	760	1774	2.930	
132	315SB	4	1900	200	150	750	750	650	13	6	23	81	81	107	568	930	1981	3.204	
160	315MB	4	1900	200	150	750	750	650	13	6	23	81	81	158	568	1020	2071	3.282	
200	315MB	4	1900	200	150	750	750	650	13	6	23	81	81	158	568	1270	2321	3.282	
250	315CB	4	2190	200	150	895	765	665	13	6	23	81	81	347	568	1600	2731	4.969	

Performance curves

HS 300-200-489
4-pole

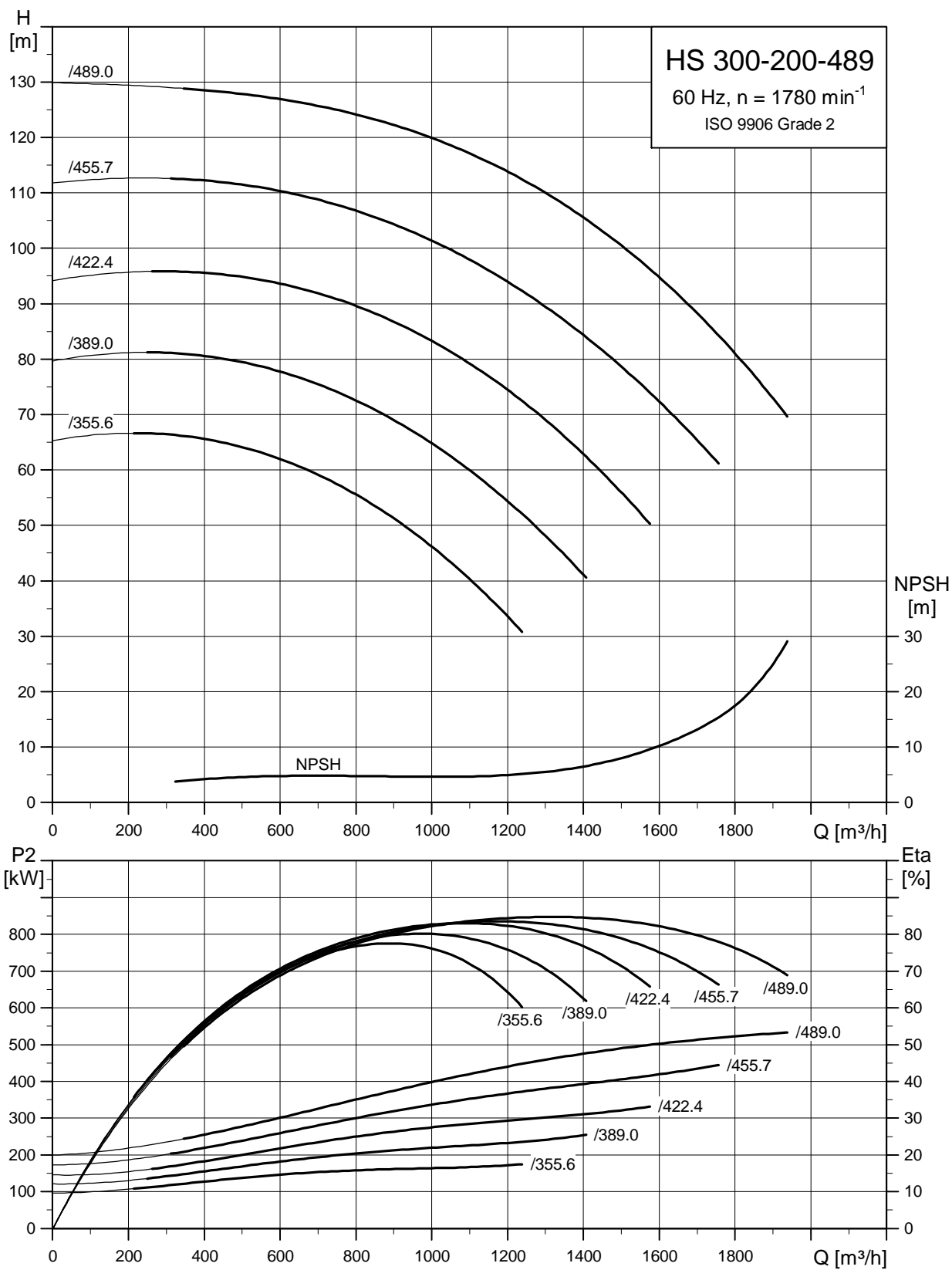

TM03 9866 4507

HS standard pump with motor

HS standard, 300-200-489

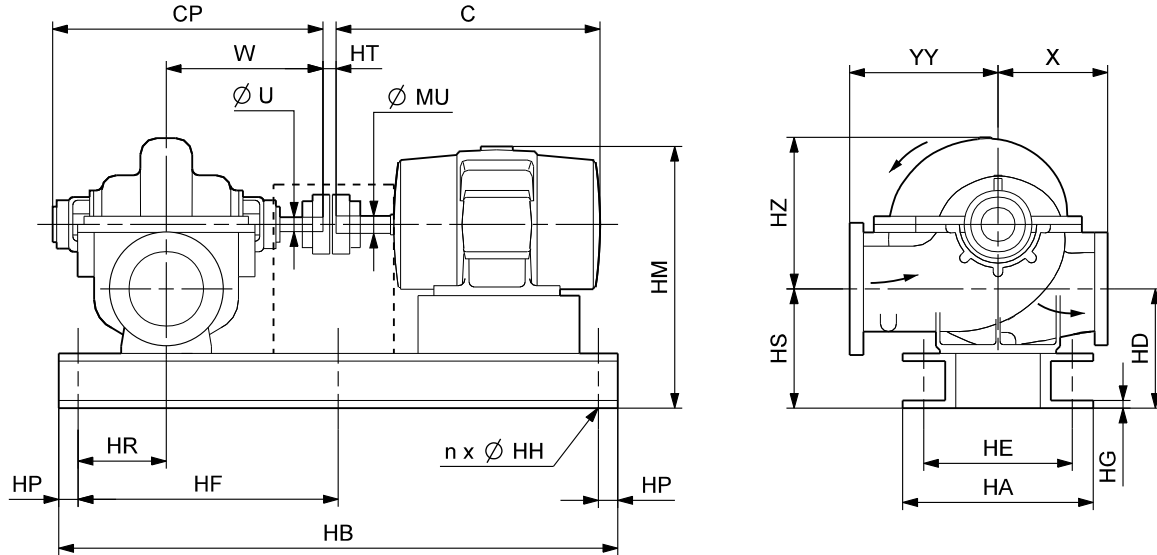

TM04 1828 1108

Dimensions

Motor			Pump dimensions [mm]									Motor dimensions [mm]			Distance between shaft ends [mm]
P ₂ [kW]	Frame size	Number of poles	CP		W	ØU	X	YY	HD	HS	HZ	C	HM	ØMU	HT
			Mechanical seal	Stuffing box											
200	315MB	4	1306	1306	723	63.50	414	559	478	478	745	1167	1237	85	3.2
250	315CB	4	1306	1306	723	63.50	414	559	478	478	745	1646	1368	95	3.2
315	315DB	4	1306	1306	723	63.50	414	559	478	478	745	1848	1368	95	3.2
335	315DB	4	1306	1306	723	63.50	414	559	478	478	745	1848	1368	95	3.2
355	355AB	4	1306	1306	723	63.50	414	559	478	478	745	1749	1451	95	3.2
375	355AB	4	1306	1306	723	63.50	414	559	478	478	745	1749	1451	95	3.2
400	355CB	4	1306	1306	723	63.50	414	559	478	478	745	1939	1451	95	3.2
450	355CB	4	1306	1306	723	63.50	414	559	478	478	745	1939	1451	95	3.2
500	400AB	4	1306	1306	723	63.50	414	559	478	478	745	1925	1471	110	4.8
525	400AB	4	1306	1306	723	63.50	414	559	478	478	745	1925	1471	110	4.8
560	400CB	4	1306	1306	723	63.50	414	559	478	478	745	2125	1471	110	4.8
600	400CB	4	1306	1306	723	63.50	414	559	478	478	745	2125	1471	110	4.8

Motor			Base frame dimensions [mm]									Overhang [mm]			Net weights [kg]			Shipping volume [m ³]
P ₂ [kW]	Frame size	Number of poles	HB	HP	HR	HF	HA	HE	HG	n	ØHH	Pump end		Motor end	Pump	Motor	Total	
												Mechanical seal	Stuffing box					
200	315MB	4	2080	200	150	840	720	650	13	6	23	233	233	163	727	1270	2539	4.278
250	315CB	4	2580	200	150	1090	735	665	13	6	23	233	233	142	727	1600	3014	6.188
315	315DB	4	2580	200	150	1090	735	665	13	6	23	233	233	344	727	1760	3174	6.611
335	315DB	4	2580	200	150	1090	735	665	13	6	23	233	233	344	727	1950	3364	6.611
355	355AB	4	2630	200	150	1115	835	765	13	6	23	233	233	195	727	2000	3489	7.325
375	355AB	4	2630	200	150	1115	835	765	13	6	23	233	233	195	727	1950	3439	7.325
400	355CB	4	2630	200	150	1115	835	765	13	6	23	233	233	385	727	2500	3989	7.780
450	355CB	4	2630	200	150	1115	835	765	13	6	23	233	233	385	727	2500	3989	7.780
500	400AB	4	2820	200	150	1210	895	825	13	6	23	233	233	183	727	3000	4543	7.929
525	400AB	4	2820	200	150	1210	895	825	13	6	23	233	233	183	727	3000	4543	7.929
560	400CB	4	2820	200	150	1210	895	825	13	6	23	233	233	383	727	3400	4943	8.419
600	400CB	4	2820	200	150	1210	895	825	13	6	23	233	233	383	727	3400	4943	8.419

Performance curves

HS 300-250-305
4-pole

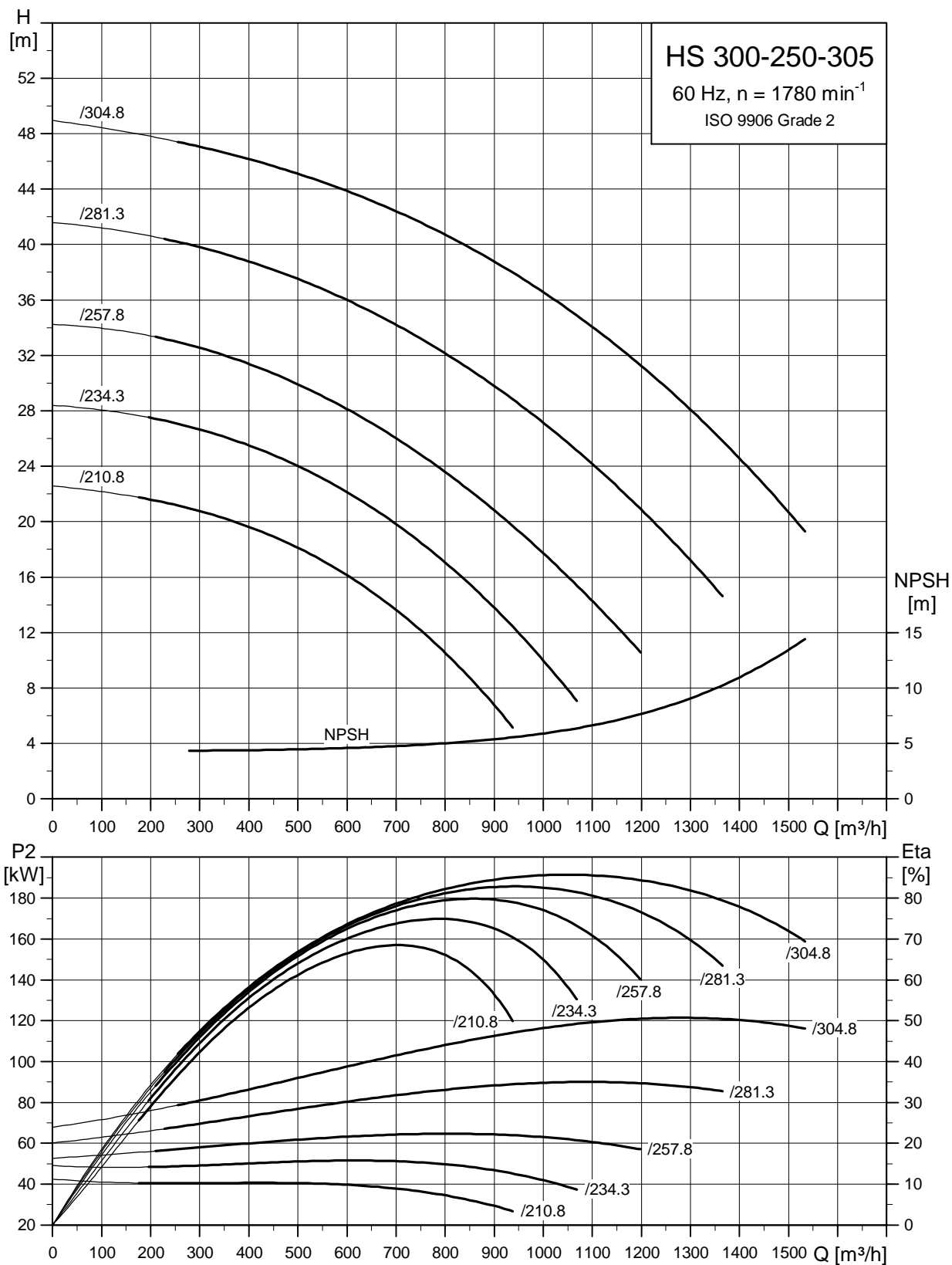

TM03 9868 4507

Dimensional sketch

HS standard, 300-250-305

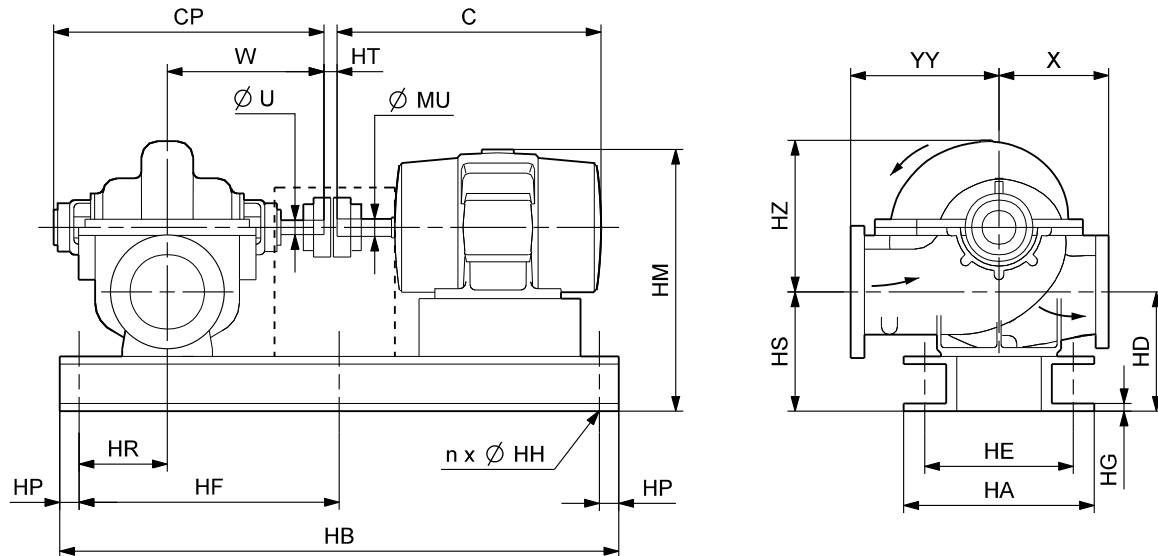

TMD04 1828 1108

Dimensions

Motor			Pump dimensions [mm]									Motor dimensions [mm]			Distance between shaft ends [mm]
P ₂ [kW]	Frame size	Number of poles	CP		W	ØU	X	YY	HD	HS	HZ	C	HM	ØMU	HT
			Mechanical seal	Stuffing box											
45	225MC	4	974	974	530	44.45	495	495	483	483	645	841	1082	60	3.2
55	250SC	4	974	974	530	44.45	495	495	483	483	645	883	1108	70	14.5
75	250MC	4	974	974	530	44.45	495	495	483	483	645	921	1108	70	14.5
90	280SB	4	974	974	530	44.45	495	495	483	483	645	1026	1163	80	14.5
110	280MB	4	974	974	530	44.45	495	495	483	483	645	1077	1163	80	14.5
132	315SB	4	974	974	530	44.45	495	495	483	483	645	1116	1211	85	24
160	315MB	4	974	974	530	44.45	495	495	483	483	645	1167	1211	85	24

Motor			Base frame dimensions [mm]									Overhang [mm]			Net weights [kg]			Shipping volume [m ³]
P ₂ [kW]	Frame size	Number of poles	HB	HP	HR	HF	HA	HE	HG	n	ØHH	Pump end		Motor end	Pump	Motor	Total	
												Mechanical seal	Stuffing box					
45	225MC	4	1630	200	150	615	535	460	13	6	23	94	94	94	636	360	1370	2.540
55	250SC	4	1700	200	150	650	585	505	13	6	23	94	94	77	636	510	1562	2.614
75	250MC	4	1700	200	150	650	585	505	13	6	23	94	94	115	636	565	1617	2.667
90	280SB	4	1830	200	150	715	645	575	13	6	23	94	94	91	636	680	1767	2.983
110	280MB	4	1830	200	150	715	645	575	13	6	23	94	94	142	636	760	1847	3.058
132	315SB	4	1910	200	150	755	720	640	13	6	23	94	94	110	636	930	2054	3.339
160	315MB	4	1910	200	150	755	720	640	13	6	23	94	94	161	636	1020	2144	3.420

Performance curves

HS 300-250-381
4-pole

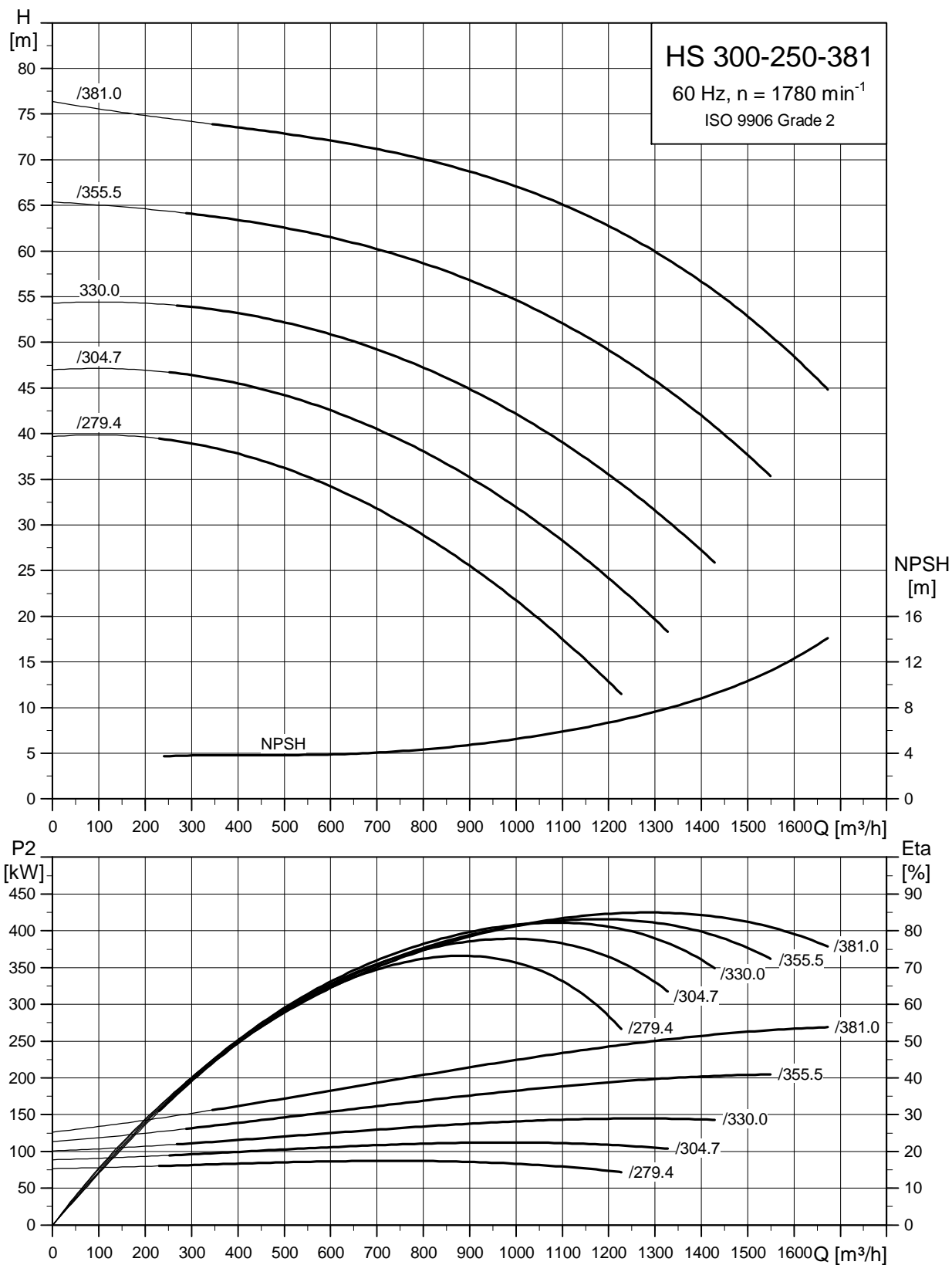

TM03 9870 4507

Dimensional sketch

HS standard, 300-250-381

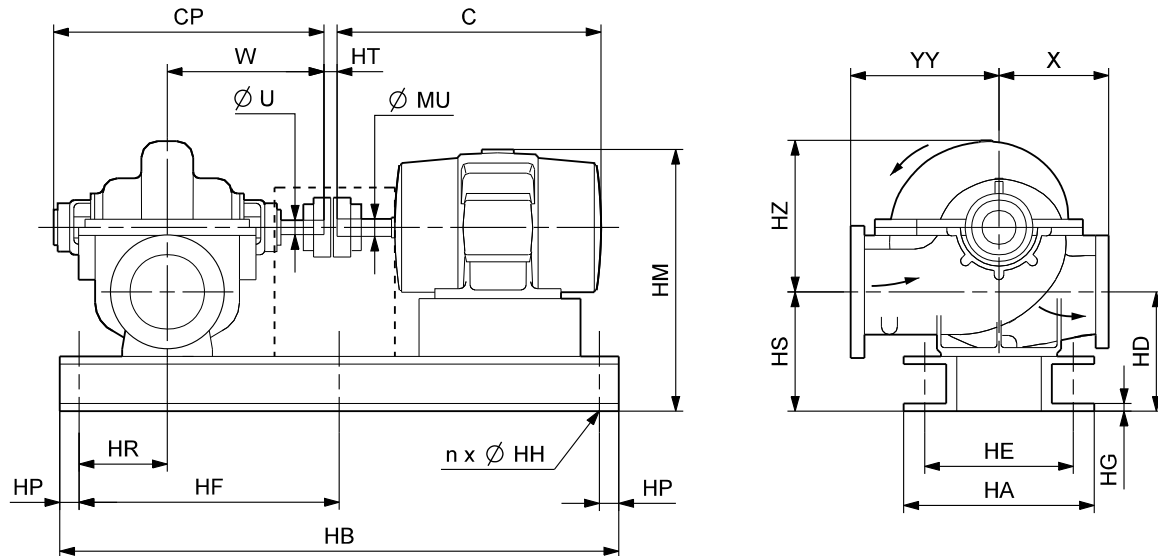

TMD04 1828 1108

Dimensions

Motor			Pump dimensions [mm]									Motor dimensions [mm]			Distance between shaft ends [mm]
P ₂ [kW]	Frame size	Number of poles	CP		W	ØU	X	YY	HD	HS	HZ	C	HM	ØMU	HT
			Mechanical seal	Stuffing box											
110	280MB	4	1051	1051	600	57.15	432	584	534	534	630	1077	1168	80	3.2
132	315SB	4	1051	1051	600	57.15	432	584	534	534	630	1116	1216	85	3.2
160	315MB	4	1051	1051	600	57.15	432	584	534	534	630	1167	1216	85	3.2
200	315MB	4	1051	1051	600	57.15	432	584	534	534	630	1167	1216	85	3.2
250	315CB	4	1051	1051	600	57.15	432	584	534	534	630	1646	1347	95	3.2
315	315DB	4	1051	1051	600	57.15	432	584	534	534	630	1848	1347	95	3.2

Motor			Base frame dimensions [mm]										Overhang [mm]			Net weights [kg]			Shipping volume [m ³]
P ₂ [kW]	Frame size	Number of poles	HB	HP	HR	HF	HA	HE	HG	n	ØHH	Pump end		Motor end	Pump	Motor	Total		
												Mechanical seal	Stuffing box						
												110	280MB	4	1820	200	80	710	645
132	315SB	4	1890	200	80	745	720	640	13	6	23	171	171	109	991	930	2408	3.854	
160	315MB	4	1890	200	80	745	720	640	13	6	23	171	171	160	991	1020	2498	3.945	
200	315MB	4	1890	200	80	745	720	640	13	6	23	171	171	160	991	1270	2748	3.945	
250	315CB	4	2380	200	80	990	735	640	13	6	23	171	171	149	991	1600	3213	5.684	
315	315DB	4	2380	200	80	990	735	640	13	6	23	171	171	351	991	1760	3373	6.109	

Performance curves

HS 350-250-498
4-pole

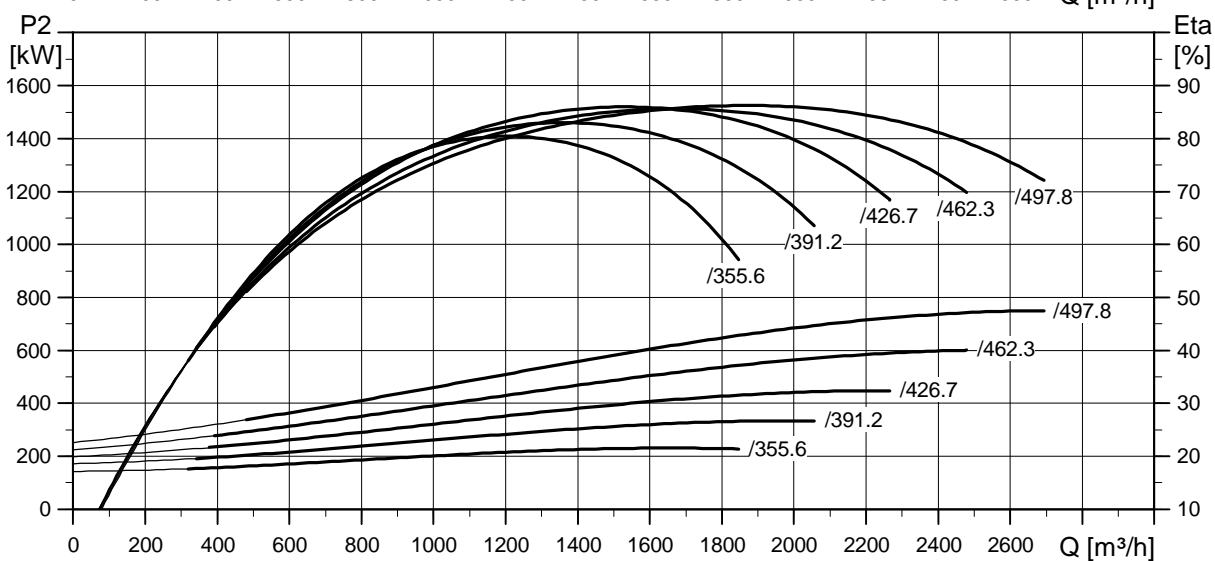
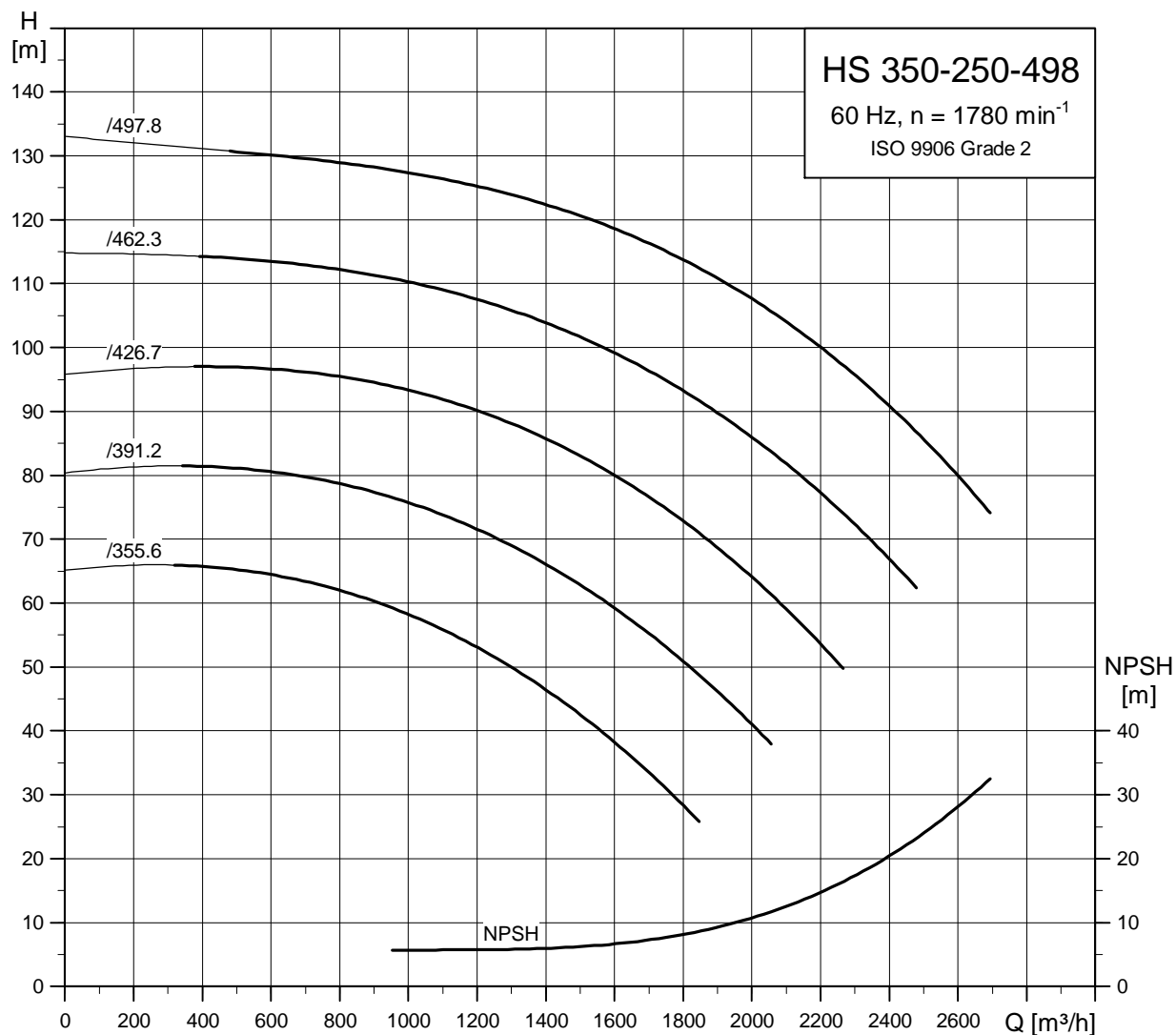

TM03 9872 4507

Dimensional sketch

HS extended, 350-250-498

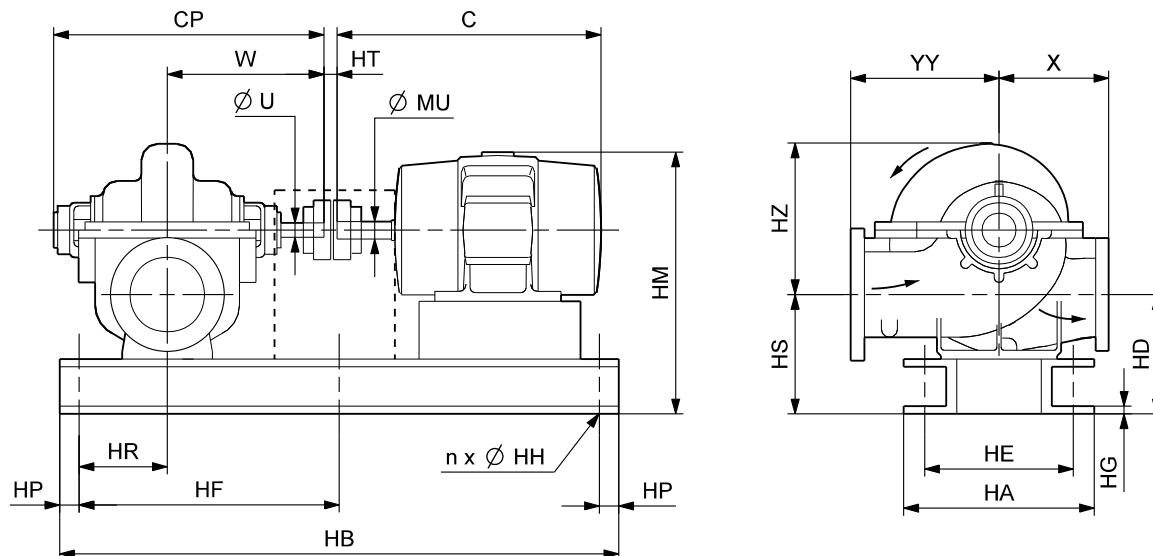

TM04 1828 1108

Dimensions

Motor			Pump dimensions [mm]							Motor dimensions [mm]			Distance between shaft ends [mm]		
P ₂ [kW]	Frame size	Number of poles	CP		W	Ø U	X	YY	HD	HS	HZ	C	HM	Ø MU	HT
			Mechanical seal	Stuffing box											
250	315CB	4	1403	1403	797	79.38	508	660	526	526	785	1646	1425	95	3.2
315	315DB	4	1403	1403	797	79.38	508	660	526	526	785	1848	1425	95	3.2
335	315DB	4	1403	1403	797	79.38	508	660	526	526	785	1848	1425	95	3.2
355	355AB	4	1403	1403	797	79.38	508	660	526	526	785	1749	1508	95	3.2
375	355AB	4	1403	1403	797	79.38	508	660	526	526	785	1749	1508	95	3.2
400	355CB	4	1403	1403	797	79.38	508	660	526	526	785	1939	1508	95	3.2
450	355CB	4	1403	1403	797	79.38	508	660	526	526	785	1939	1508	95	3.2
500	400AB	4	1403	1403	797	79.38	508	660	526	526	785	1925	1528	110	4.8
525	400AB	4	1403	1403	797	79.38	508	660	526	526	785	1925	1528	110	4.8
560	400CB	4	1403	1403	797	79.38	508	660	526	526	785	2125	1528	110	4.8
600	400CB	4	1403	1403	797	79.38	508	660	526	526	785	2125	1528	110	4.8

Motor			Base frame dimensions [mm]								Overhang [mm]			Net weights [kg]			Shipping volume [m ³]	
P ₂ [kW]	Frame size	Number of poles	HB	HP	HR	HF	HA	HE	HG	n	Ø HH	Pump end		Motor end	Pump	Motor		Total
												Mechanical seal	Stuffing box					
250	315CB	4	2650	200	150	1125	735	655	13	6	23	256	256	146	1436	1600	3768	7.210
315	315DB	4	2650	200	150	1125	735	655	13	6	23	256	256	348	1436	1760	3928	7.687
335	315DB	4	2650	200	150	1125	735	655	13	6	23	256	256	348	1436	1950	4118	7.687
355	355AB	4	2700	200	150	1150	855	765	13	6	23	256	256	199	1436	2000	4238	8.459
375	355AB	4	2700	200	150	1150	855	765	13	6	23	256	256	199	1436	1950	4188	8.459
400	355CB	4	2700	200	150	1150	855	765	13	6	23	256	256	389	1436	2500	4738	8.968
450	355CB	4	2700	200	150	1150	855	765	13	6	23	256	256	389	1436	2500	4738	8.968
500	400AB	4	2890	200	150	1245	895	815	13	6	23	256	256	187	1436	3000	5312	9.130
525	400AB	4	2890	200	150	1245	895	815	13	6	23	256	256	187	1436	3000	5312	9.130
560	400CB	4	2890	200	150	1245	895	815	13	6	23	256	256	387	1436	3400	5712	9.678
600	400CB	4	2890	200	150	1245	895	815	13	6	23	256	256	387	1436	3400	5712	9.678

Performance curves

HS 350-250-630
4-pole

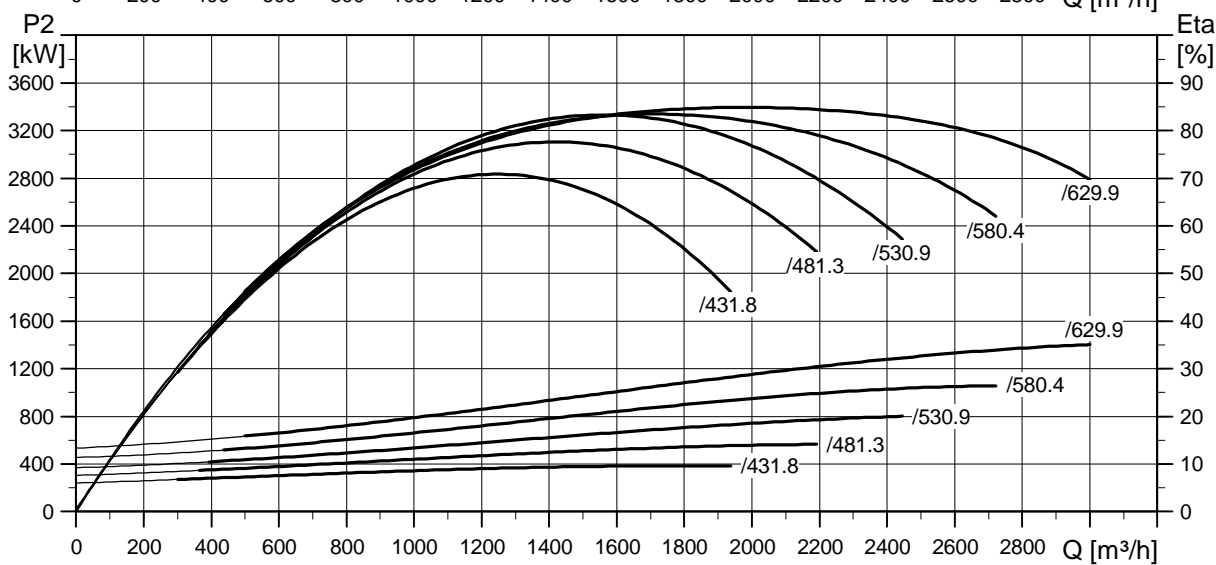
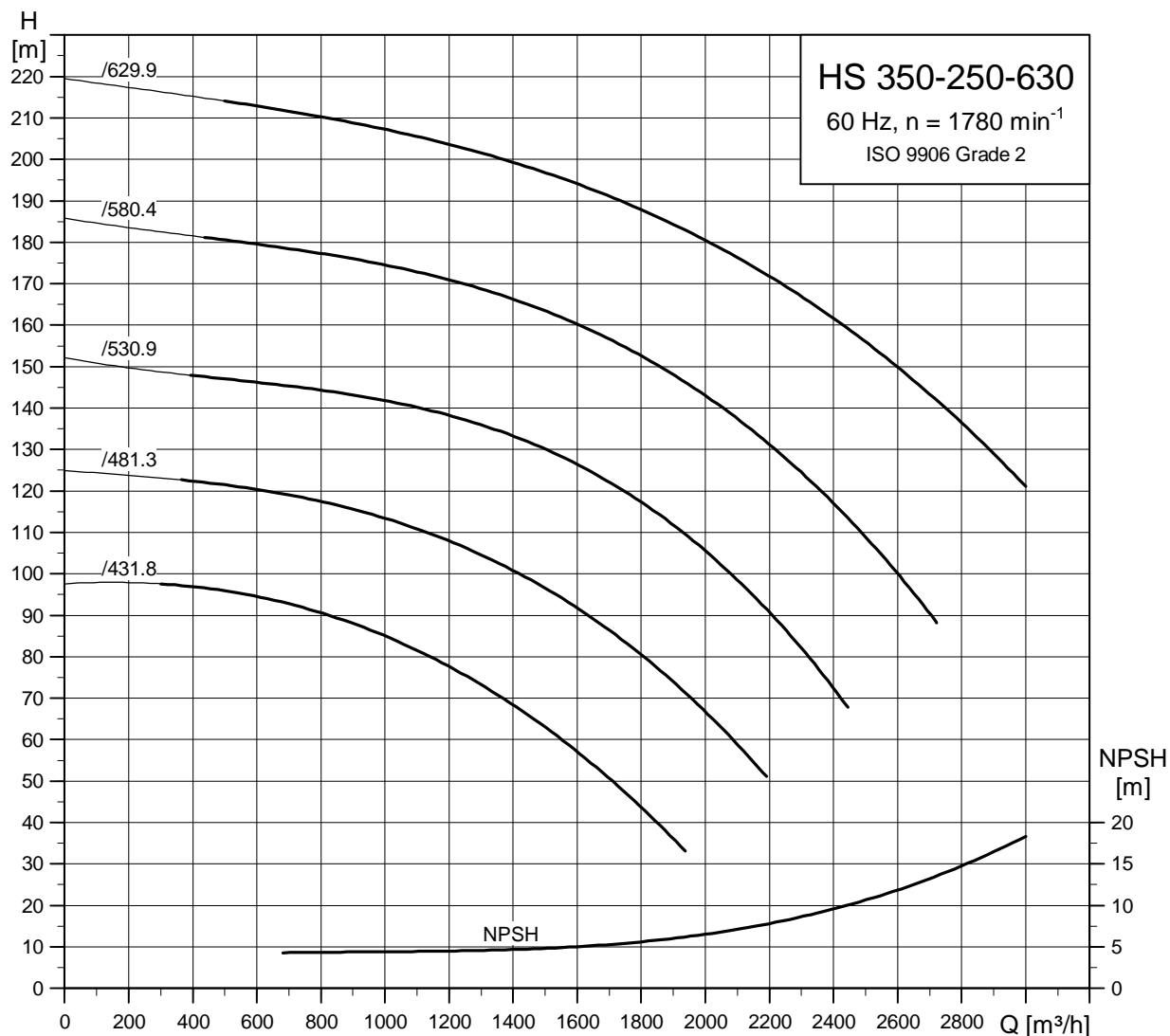

TM03 9874 4507

Dimensional sketch

HS extended, 350-250-630

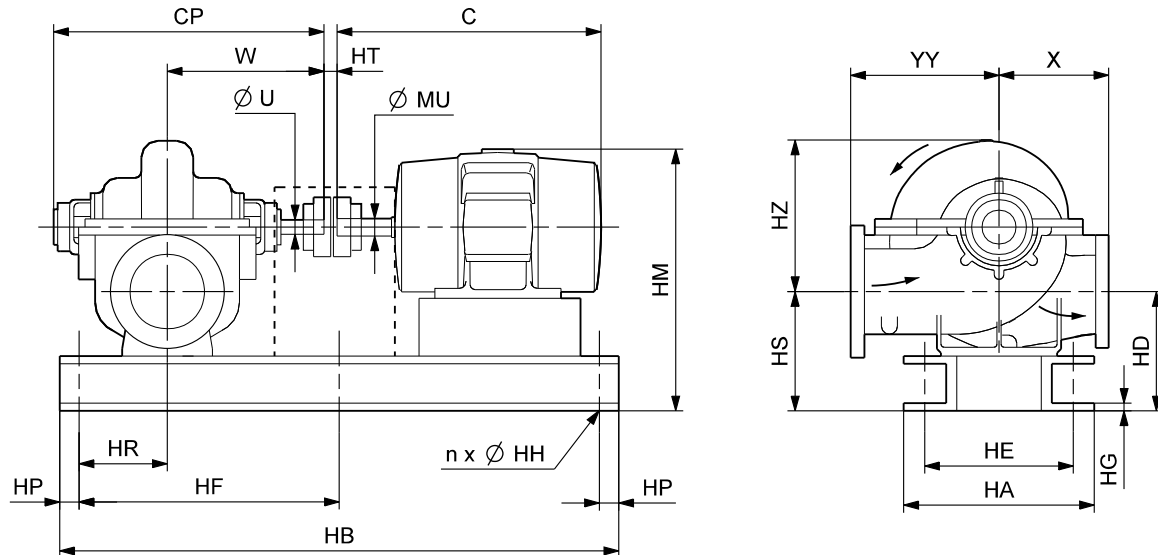

TM04 1828 1108

Dimensions

Motor			Pump dimensions [mm]							Motor dimensions [mm]			Distance between shaft ends [mm]		
P ₂ [kW]	Frame size	Number of poles	CP		W	ØU	X	YY	HD	HS	HZ	C	HM	ØMU	HT
			Mechanical seal	Stuffing box											
450	355CB	4	1377	1377	799	79.38	610	711	585	585	820	1939	1557	95	3.2
500	400AB	4	1377	1377	799	79.38	610	711	585	585	820	1925	1577	110	4.8
525	400AB	4	1377	1377	799	79.38	610	711	585	585	820	1925	1577	110	4.8
560	400CB	4	1377	1377	799	79.38	610	711	585	585	820	2125	1577	110	4.8
600	400CB	4	1377	1377	799	79.38	610	711	585	585	820	2125	1577	110	4.8

Motor			Base frame dimensions [mm]									Overhang [mm]			Net weights [kg]			Shipping volume [m ³]
P ₂ [kW]	Frame size	Number of poles	HB	HP	HR	HF	HA	HE	HG	n	ØHH	Pump end		Motor end	Pump	Motor	Total	
												Mechanical seal	Stuffing box					
450	355CB	4	2710	200	150	1155	835	745	13	6	23	228	228	381	1905	2500	5261	9.516
500	400AB	4	2890	200	150	1245	895	810	13	6	23	228	228	188	1905	3000	5810	9.680
525	400AB	4	2890	200	150	1245	895	810	13	6	23	228	228	188	1905	3000	5810	9.680
560	400CB	4	2890	200	150	1245	895	810	13	6	23	228	228	388	1905	3400	6210	10.266
600	400CB	4	2890	200	150	1245	895	810	13	6	23	228	228	388	1905	3400	6210	10.266

Performance curves

HS 400-350-397
4-pole

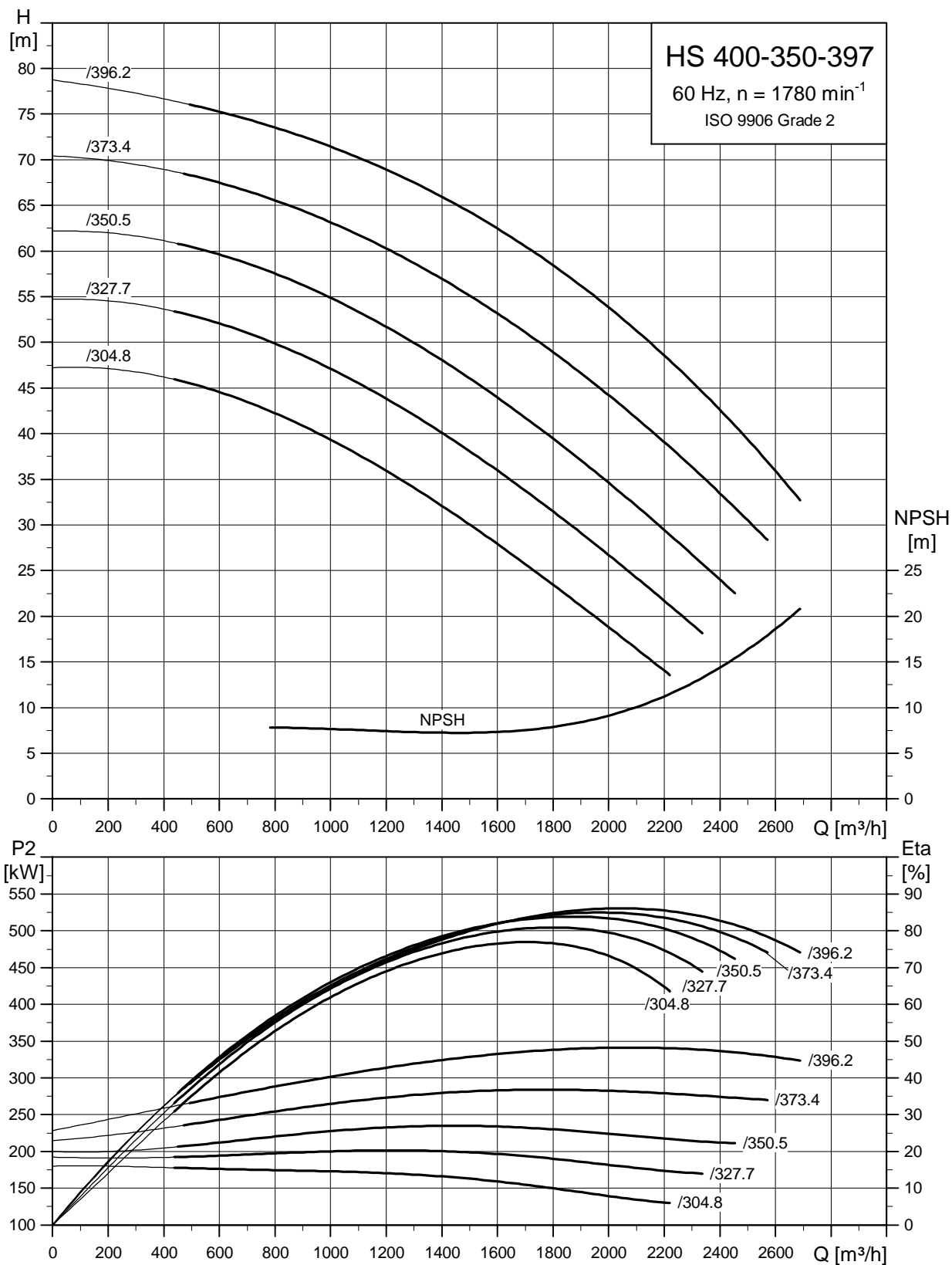

TM03 9877 4507

Dimensional sketch

HS extended, 400-350-397

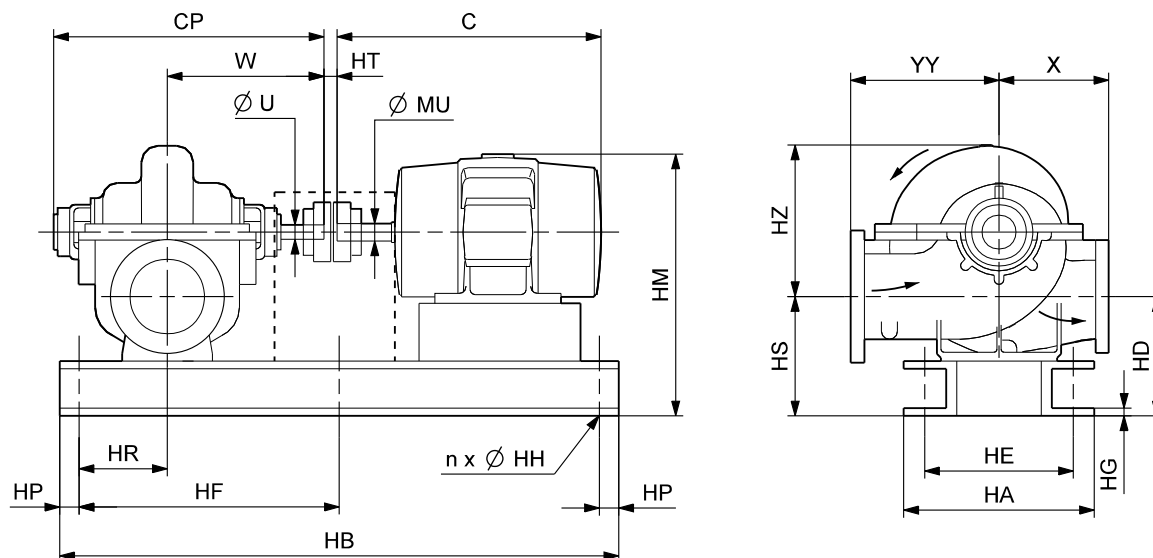

TM04 1828 1108

Dimensions

Motor			Pump dimensions [mm]									Motor dimensions [mm]			Distance between shaft ends [mm]
P ₂ [kW]	Frame size	Number of poles	CP		W	ØU	X	YY	HD	HS	HZ	C	HM	ØMU	HT
			Mechanical seal	Stuffing box											
200	315MB	4	1299	1299	723	63.50	550	650	600	600	800	1167	1378	85	3.2
250	315CB	4	1299	1299	723	63.50	550	650	600	600	800	1646	1509	95	3.2
315	315DB	4	1299	1299	723	63.50	550	650	600	600	800	1848	1509	95	3.2
335	315DB	4	1299	1299	723	63.50	550	650	600	600	800	1848	1509	95	3.2
355	355AB	4	1299	1299	723	63.50	550	650	600	600	800	1749	1592	95	3.2
375	355AB	4	1299	1299	723	63.50	550	650	600	600	800	1749	1592	95	3.2
400	355CB	4	1299	1299	723	63.50	550	650	600	600	800	1939	1592	95	3.2

Motor			Base frame dimensions [mm]									Overhang [mm]			Net weights [kg]			Shipping volume [m ³]
P ₂ [kW]	Frame size	Number of poles	HB	HP	HR	HF	HA	HE	HG	n	ØHH	Pump end		Motor end	Pump	Motor	Total	
												Mechanical seal	Stuffing box					
200	315MB	4	2160	200	230	880	845	775	13	6	23	146	146	163	1460	1270	3388	5.618
250	315CB	4	2660	200	230	1130	845	760	13	6	23	146	146	142	1460	1600	3883	7.319
315	315DB	4	2660	200	230	1130	845	760	13	6	23	146	146	344	1460	1760	4043	7.820
335	315DB	4	2660	200	230	1130	845	760	13	6	23	146	146	344	1460	1950	4233	7.820
355	355AB	4	2710	200	230	1155	845	775	13	6	23	146	146	195	1460	2000	4343	8.574
375	355AB	4	2710	200	230	1155	845	775	13	6	23	146	146	195	1460	1950	4293	8.574
400	355CB	4	2710	200	230	1155	845	775	13	6	23	146	146	385	1460	2500	4843	9.108

Performance curves

HS 200-150-483
6-pole

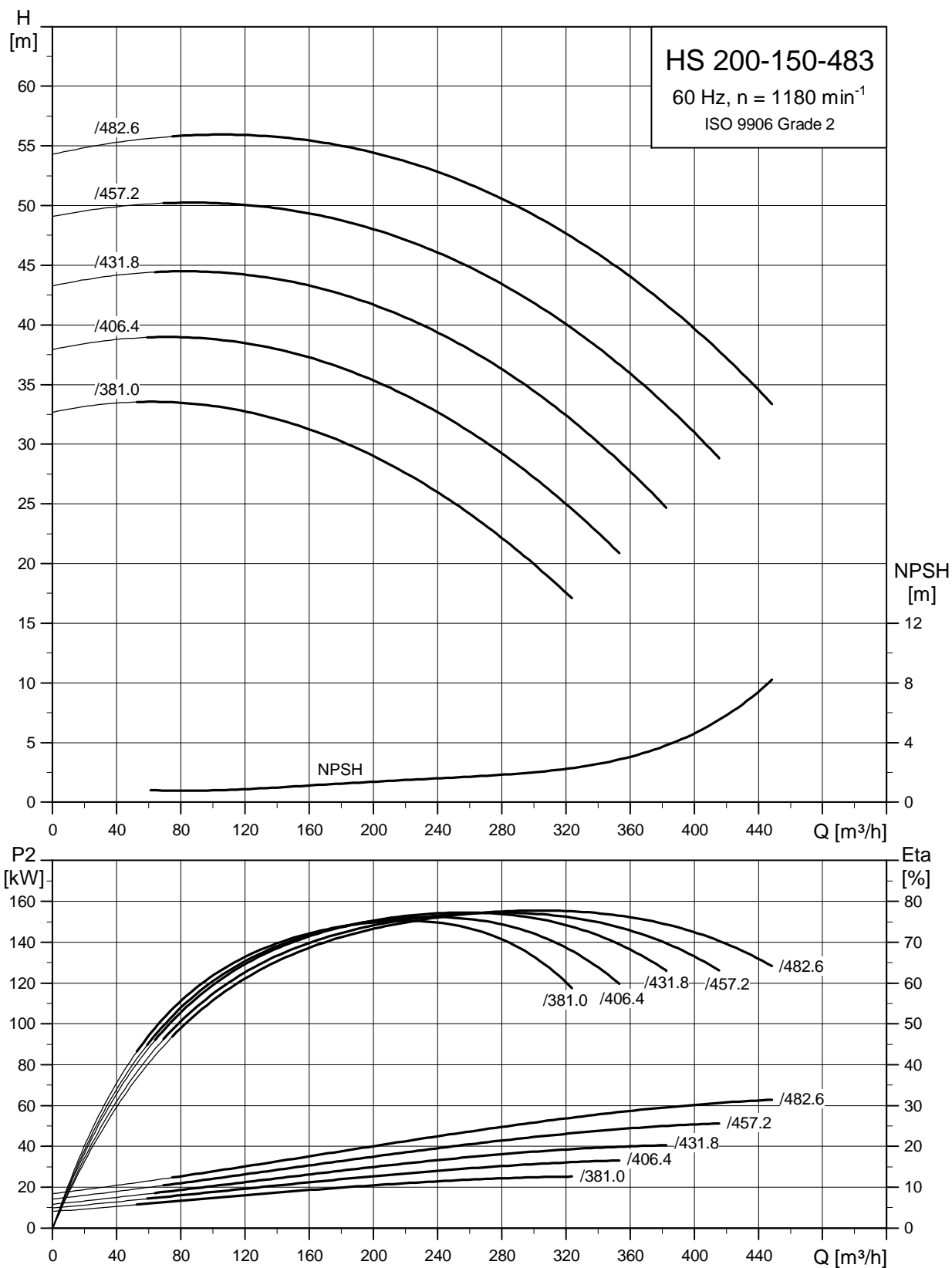

TM03 9860 4507

Dimensional sketch

HS extended, 200-150-483

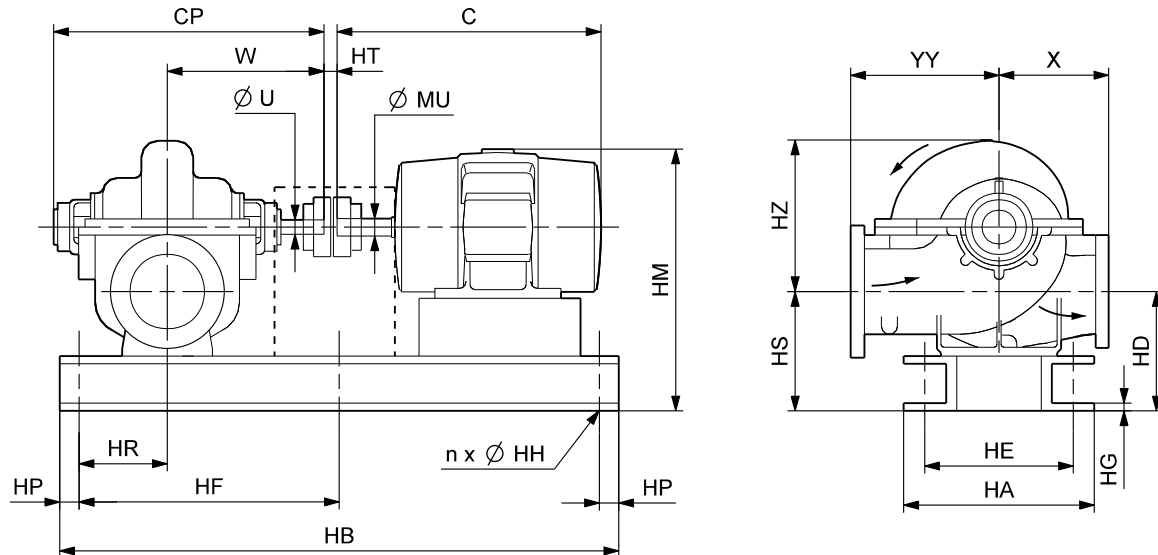

TM04 1828 1108

Dimensions

Motor			Pump dimensions [mm]									Motor dimensions [mm]			Distance between shaft ends [mm]
P ₂ [kW]	Frame size	Number of poles	CP		W	Ø U	X	YY	HD	HS	HZ	C	HM	Ø MU	HT
			Mechanical seal	Stuffing box											
30	225MC	6	888	888	489	44.45	432	432	391	391	615	841	951	60	3.2
37	250SC	6	888	888	489	44.45	432	432	391	391	615	883	977	70	11.5
45	250MC	6	888	888	489	44.45	432	432	391	391	615	921	977	70	11.5
55	280SB	6	888	888	489	44.45	432	432	391	391	615	1026	1032	80	11.5
75	280MB	6	888	888	489	44.45	432	432	391	391	615	1077	1032	80	11.5

Motor			Base frame dimensions [mm]									Overhang [mm]			Net weights [kg]			Shipping volume [m ³]
P ₂ [kW]	Frame size	Number of poles	HB	HP	HR	HF	HA	HE	HG	n	Ø HH	Pump end		Motor end	Pump	Motor	Total	
												Mechanical seal	Stuffing box					
30	225MC	6	1520	200	80	560	535	465	11	6	23	119	119	93	534	360	1143	1.882
37	250SC	6	1590	200	80	595	585	515	11	6	23	119	119	73	534	510	1322	2.074
45	250MC	6	1590	200	80	595	585	515	11	6	23	119	119	111	534	565	1377	2.118
55	280SB	6	1720	200	80	660	645	575	11	6	23	119	119	86	534	650	1485	2.372
75	280MB	6	1720	200	80	660	645	575	11	6	23	119	119	137	534	730	1565	2.434

Performance curves

HS 200-150-508
6-pole

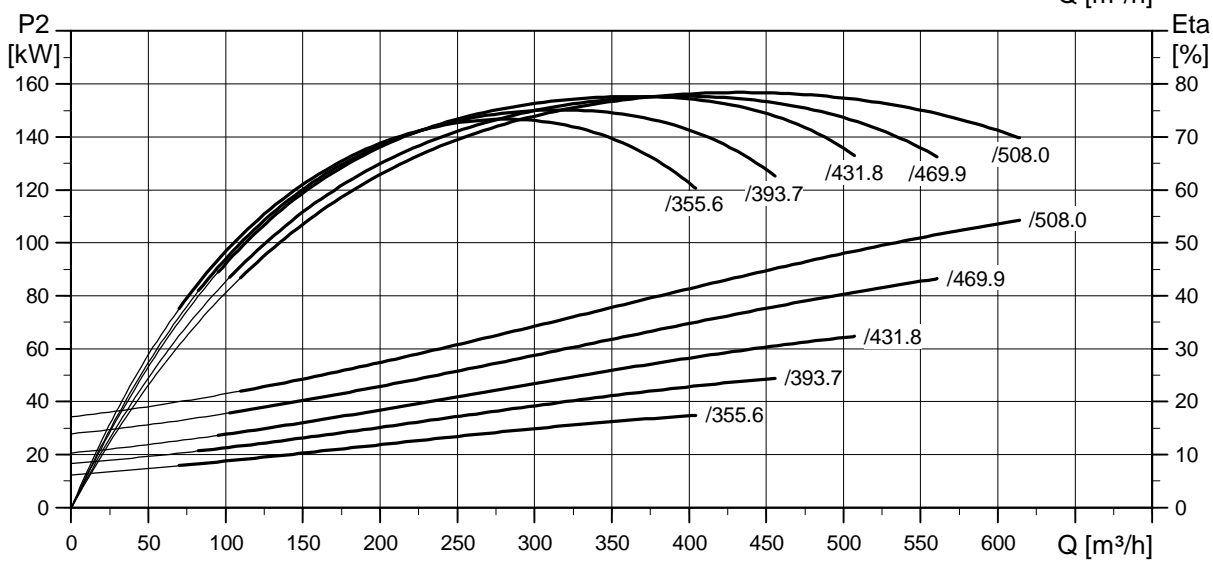
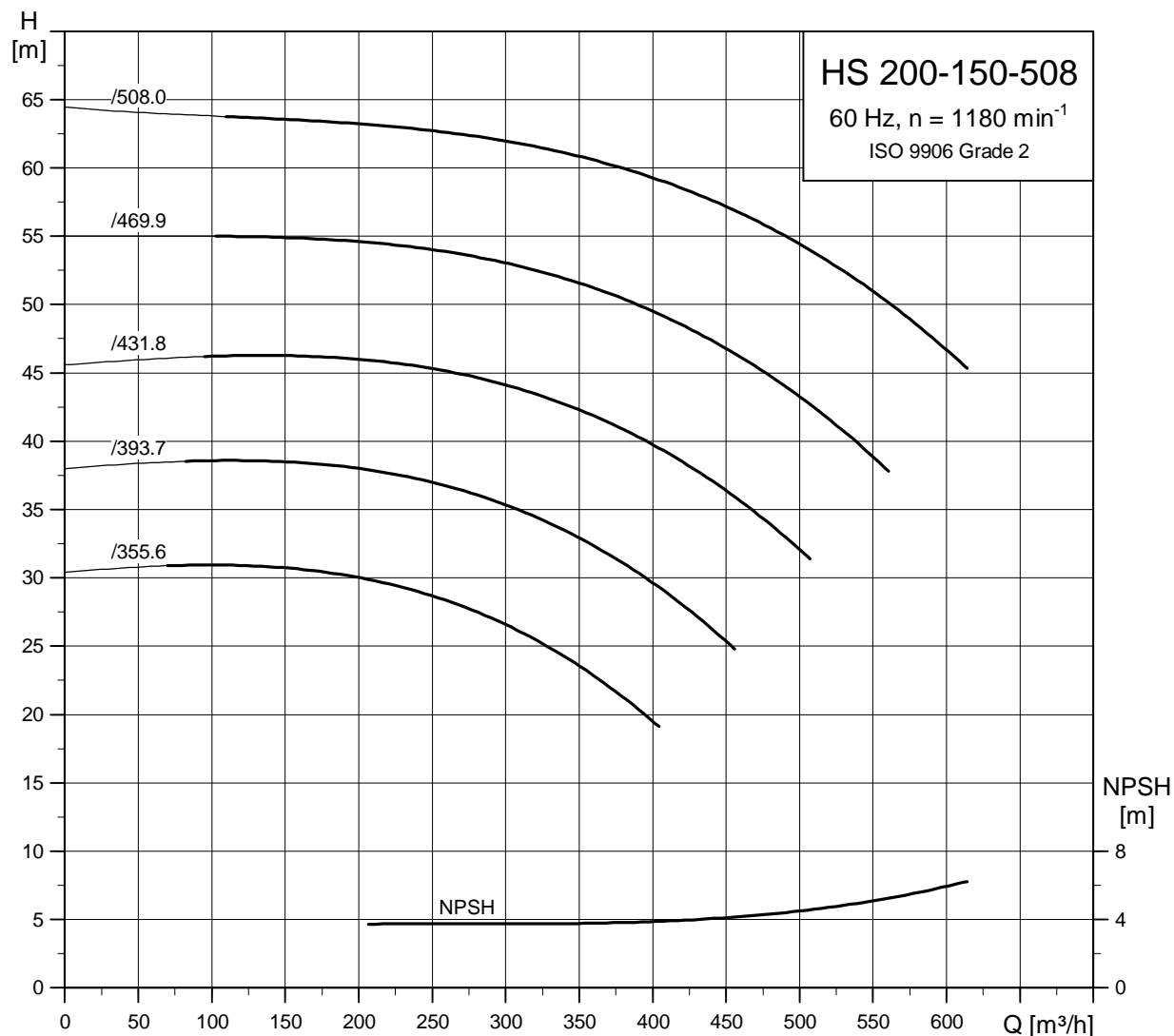

TM03 9862 4507

Dimensional sketch

HS extended, 200-150-508

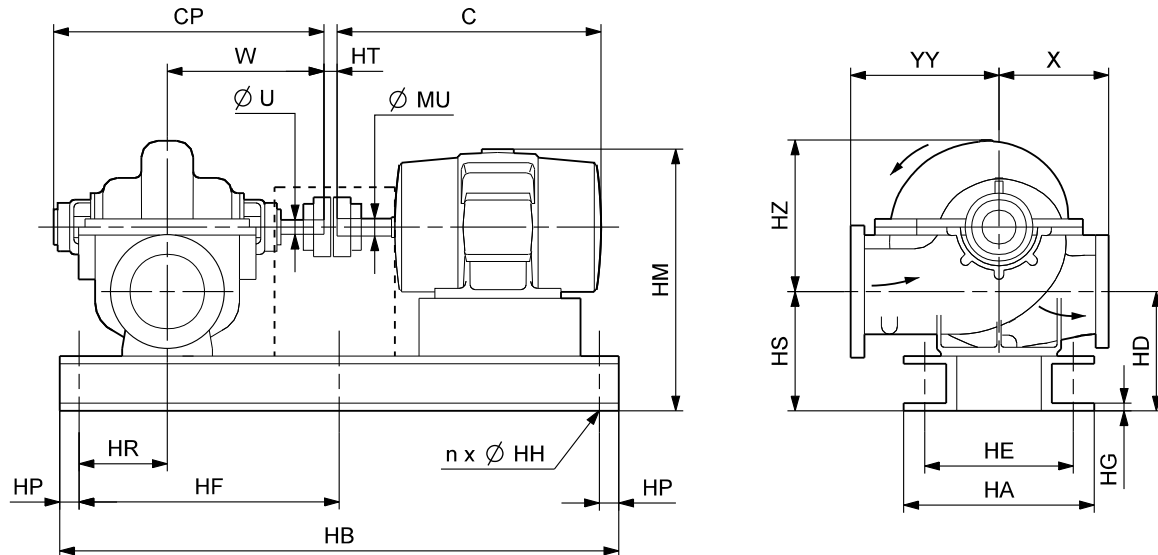

TM04 1828 1108

Dimensions

Motor			Pump dimensions [mm]									Motor dimensions [mm]			Distance between shaft ends [mm]
P ₂ [kW]	Frame size	Number of poles	CP		W	ØU	X	YY	HD	HS	HZ	C	HM	ØMU	HT
			Mechanical seal	Stuffing box											
37	250SC	6	995	995	546	53.98	432	483	391	391	660	883	996	70	3.5
45	250MC	6	995	995	546	53.98	432	483	391	391	660	921	996	70	3.5
55	280SB	6	995	995	546	53.98	432	483	391	391	660	1026	1051	80	3.5
75	280MB	6	995	995	546	53.98	432	483	391	391	660	1077	1051	80	3.5
90	315SB	6	995	995	546	53.98	432	483	391	391	660	1116	1099	85	13
110	315MB	6	995	995	546	53.98	432	483	391	391	660	1167	1099	85	13
132	315MB	6	995	995	546	53.98	432	483	391	391	660	1167	1099	85	13

Motor			Base frame dimensions [mm]										Overhang [mm]			Net weights [kg]			Shipping volume [m ³]
P ₂ [kW]	Frame size	Number of poles	HB	HP	HR	HF	HA	HE	HG	n	ØHH	Pump end		Motor end	Pump	Motor	Total		
												Mechanical seal	Stuffing box						
37	250SC	6	1640	200	80	620	585	515	11	6	23	168	168	72	545	510	1344	2.411	
45	250MC	6	1640	200	80	620	585	515	11	6	23	168	168	110	545	565	1399	2.460	
55	280SB	6	1770	200	80	685	645	575	11	6	23	168	168	86	545	650	1506	2.675	
75	280MB	6	1770	200	80	685	645	575	11	6	23	168	168	137	545	730	1586	2.743	
90	315SB	6	1840	200	80	720	720	650	11	6	23	168	168	115	545	920	1808	3.006	
110	315MB	6	1840	200	80	720	720	650	11	6	23	168	168	166	545	1020	1908	3.078	
132	315MB	6	1840	200	80	720	720	650	11	6	23	168	168	166	545	1040	1928	3.078	

Performance curves

HS 250-200-381
6-pole

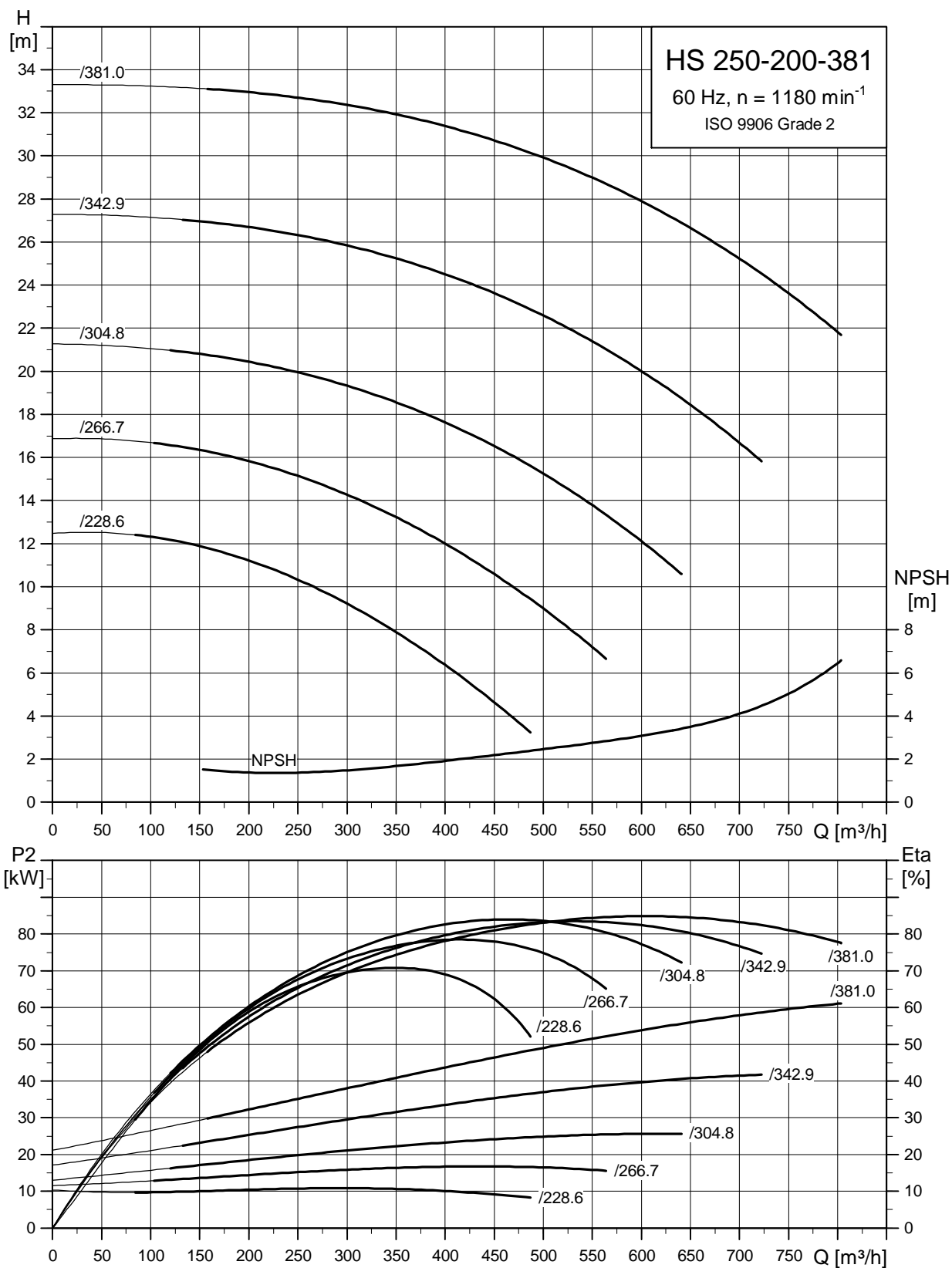

TM03 9865 4507

Dimensional sketch

HS extended, 250-200-381

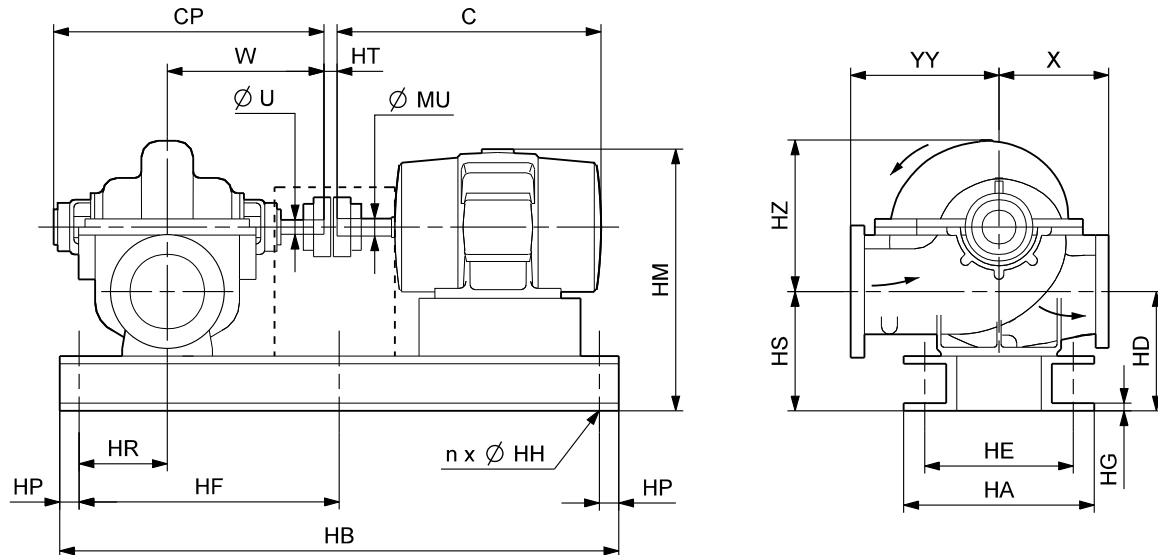

TM04 1828 1108

Dimensions

Motor			Pump dimensions [mm]									Motor dimensions [mm]			Distance between shaft ends [mm]
P ₂ [kW]	Frame size	Number of poles	CP		W	Ø U	X	YY	HD	HS	HZ	C	HM	Ø MU	HT
			Mechanical seal	Stuffing box											
15	180LC	6	949	949	518	44.45	483	483	458	458	655	710	1004	48	3.2
18.5	200LC	6	949	949	518	44.45	483	483	458	458	655	775	1032	55	3.2
22	200LC	6	949	949	518	44.45	483	483	458	458	655	775	1032	55	3.2
30	225MC	6	949	949	518	44.45	483	483	458	458	655	841	1062	60	3.2
37	250SC	6	949	949	518	44.45	483	483	458	458	655	883	1088	70	14.5
45	250MC	6	949	949	518	44.45	483	483	458	458	655	921	1088	70	14.5
55	280SB	6	949	949	518	44.45	483	483	458	458	655	1026	1143	80	14.5
75	280MB	6	949	949	518	44.45	483	483	458	458	655	1077	1143	80	14.5

Motor			Base frame dimensions [mm]										Overhang [mm]			Net weights [kg]			Shipping volume [m ³]
P ₂ [kW]	Frame size	Number of poles	HB	HP	HR	HF	HA	HE	HG	n	Ø HH	Pump end		Motor end	Pump	Motor	Total		
												Mechanical seal	Stuffing box						
15	180LC	6	1520	200	150	560	500	410	13	6	23	81	81	61	568	205	1112	2.231	
18.5	200LC	6	1560	200	150	580	515	415	13	6	23	81	81	85	568	280	1199	2.318	
22	200LC	6	1560	200	150	580	515	415	13	6	23	81	81	85	568	280	1199	2.318	
30	225MC	6	1620	200	150	610	565	465	13	6	23	81	81	92	568	360	1302	2.407	
37	250SC	6	1690	200	150	645	615	515	13	6	23	81	81	74	568	510	1484	2.505	
45	250MC	6	1690	200	150	645	615	515	13	6	23	81	81	112	568	565	1539	2.556	
55	280SB	6	1820	200	150	710	675	575	13	6	23	81	81	88	568	650	1664	2.857	
75	280MB	6	1820	200	150	710	675	575	13	6	23	81	81	139	568	730	1744	2.930	

Performance curves

HS 300-200-489
6-pole

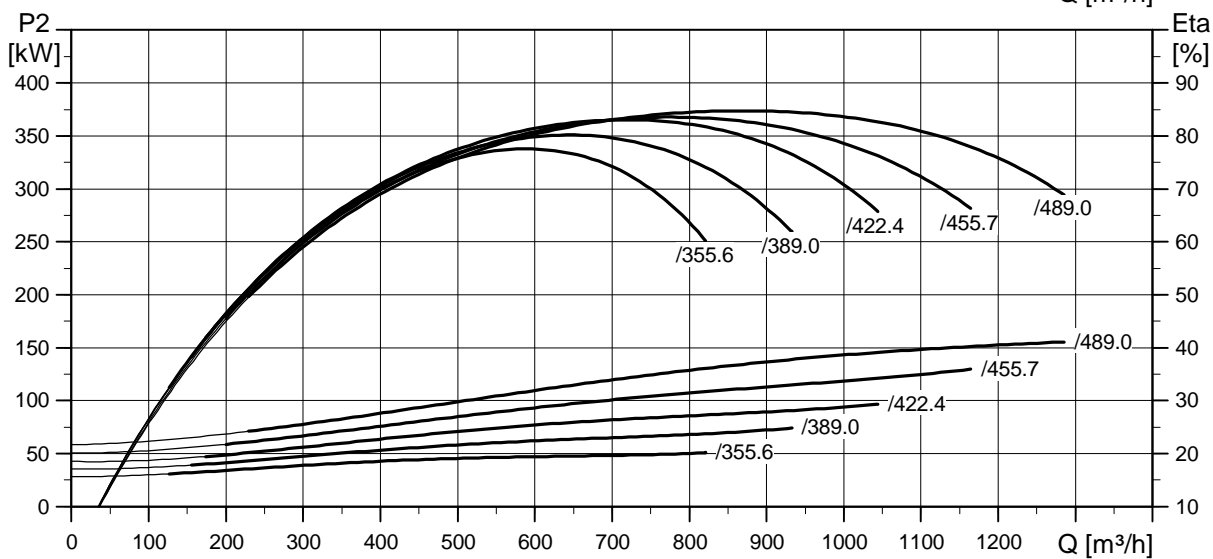
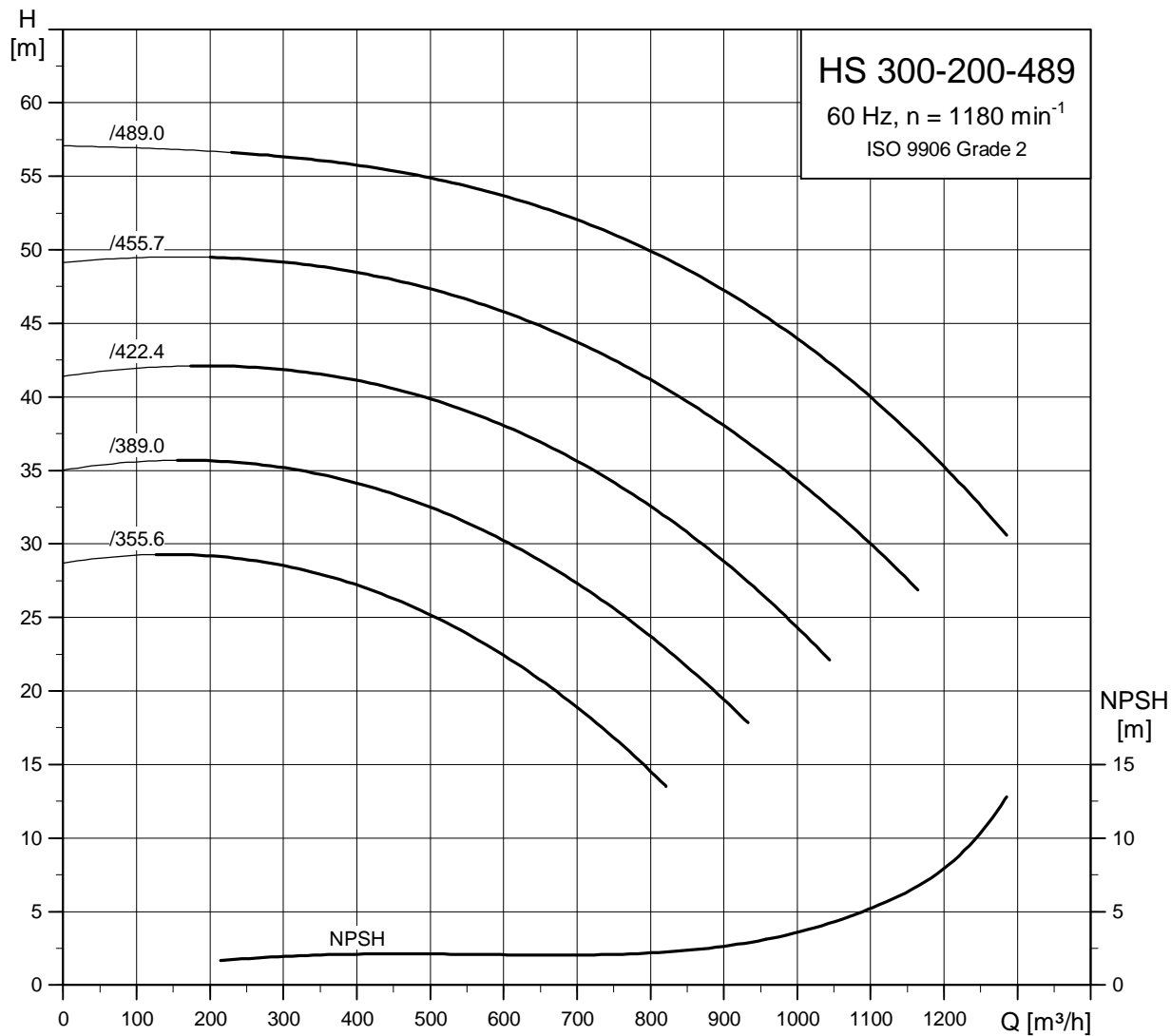

TM03 9867 4507

Dimensional sketch

HS extended, 300-200-489

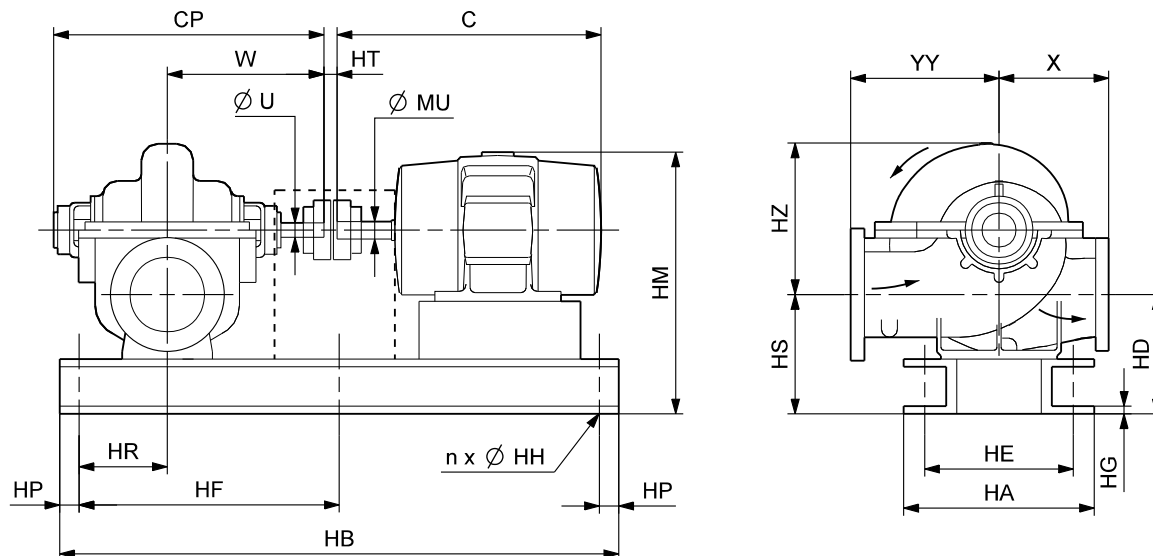

TM04 1828 1108

Dimensions

Motor			Pump dimensions [mm]									Motor dimensions [mm]			Distance between shaft ends [mm]
P ₂ [kW]	Frame size	Number of poles	CP		W	ØU	X	YY	HD	HS	HZ	C	HM	ØMU	HT
			Mechanical seal	Stuffing box											
55	280SB	6	1306	1306	723	63.50	414	559	478	478	745	1026	1189	80	3.2
75	280MB	6	1306	1306	723	63.50	414	559	478	478	745	1077	1189	80	3.2
90	315SB	6	1306	1306	723	63.50	414	559	478	478	745	1116	1237	85	3.2
110	315MB	6	1306	1306	723	63.50	414	559	478	478	745	1167	1237	85	3.2
132	315MB	6	1306	1306	723	63.50	414	559	478	478	745	1167	1237	85	3.2
160	315CB	6	1306	1306	723	63.50	414	559	478	478	745	1646	1368	95	3.2
200	315CB	6	1306	1306	723	63.50	414	559	478	478	745	1646	1368	95	3.2

Motor			Base frame dimensions [mm]										Overhang [mm]			Net weights [kg]			Shipping volume [m ³]
P ₂ [kW]	Frame size	Number of poles	HB	HP	HR	HF	HA	HE	HG	n	ØHH	Pump end		Motor end	Pump	Motor	Total		
												Mechanical seal	Stuffing box						
55	280SB	6	2010	200	150	805	703	633	13	6	23	233	233	92	727	650	1907	3.992	
75	280MB	6	2010	200	150	805	703	633	13	6	23	233	233	143	727	730	1987	4.079	
90	315SB	6	2080	200	150	840	720	650	13	6	23	233	233	112	727	920	2189	4.190	
110	315MB	6	2080	200	150	840	720	650	13	6	23	233	233	163	727	1020	2289	4.278	
132	315MB	6	2080	200	150	840	720	650	13	6	23	233	233	163	727	1040	2309	4.278	
160	315CB	6	2580	200	150	1090	735	665	13	6	23	233	233	142	727	1600	3014	6.188	
200	315CB	6	2580	200	150	1090	735	665	13	6	23	233	233	142	727	1780	3194	6.188	

Performance curves

HS 300-250-305
6-pole

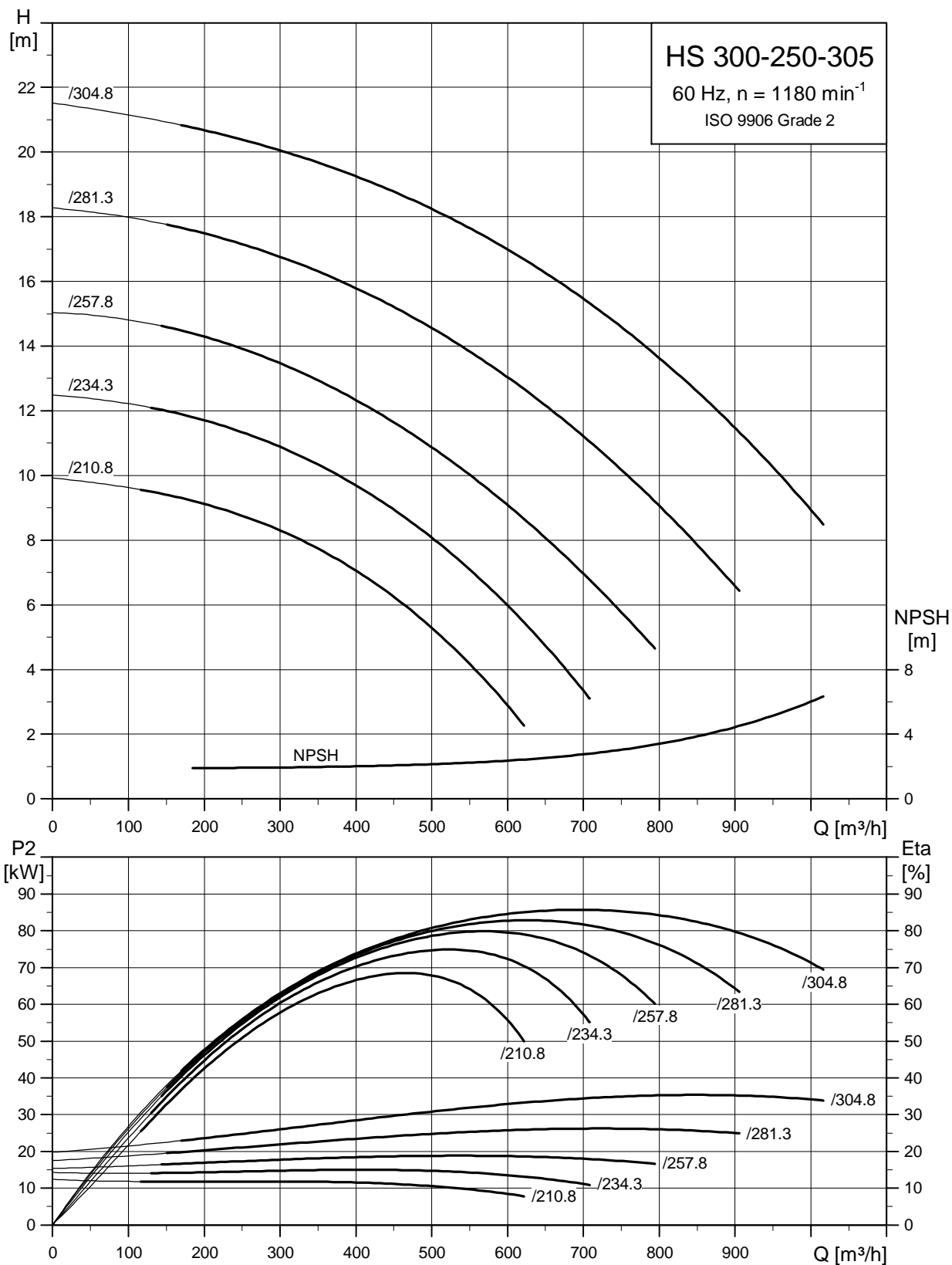

TM03 9869 4507

Dimensional sketch

HS extended, 300-250-305

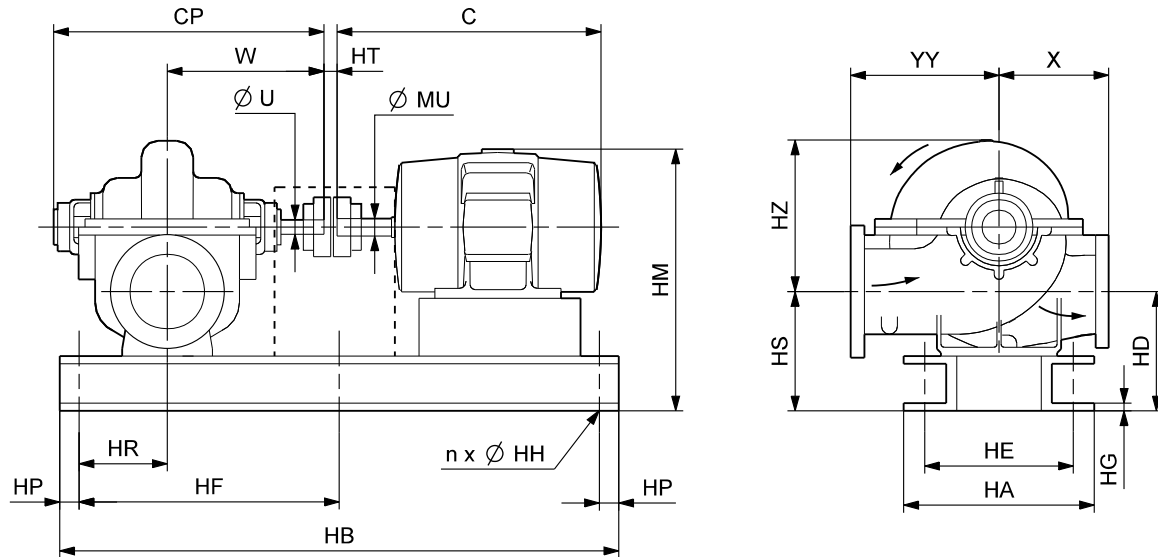

TM04 1828 1108

Dimensions

Motor			Pump dimensions [mm]									Motor dimensions [mm]			Distance between shaft ends [mm]
P ₂ [kW]	Frame size	Number of poles	CP		W	Ø U	X	YY	HD	HS	HZ	C	HM	Ø MU	HT
			Mechanical seal	Stuffing box											
15	180LC	6	974	974	530	44.45	495	495	483	483	645	710	1024	48	3.2
18.5	200LC	6	974	974	530	44.45	495	495	483	483	645	775	1052	55	3.2
22	200LC	6	974	974	530	44.45	495	495	483	483	645	775	1052	55	3.2
30	225MC	6	974	974	530	44.45	495	495	483	483	645	841	1082	60	3.2
37	250SC	6	974	974	530	44.45	495	495	483	483	645	883	1108	70	14.5
45	250MC	6	974	974	530	44.45	495	495	483	483	645	921	1108	70	14.5

Motor			Base frame dimensions [mm]										Overhang [mm]			Net weights [kg]			Shipping volume [m ³]
P ₂ [kW]	Frame size	Number of poles	HB	HP	HR	HF	HA	HE	HG	n	Ø HH	Pump end		Motor end	Pump	Motor	Total		
												Mechanical seal	Stuffing box						
												15	180LC	6	1540	200	150	570	470
18.5	200LC	6	1580	200	150	590	515	415	13	6	23	94	94	78	636	280	1272	2.447	
22	200LC	6	1580	200	150	590	515	415	13	6	23	94	94	78	636	280	1272	2.447	
30	225MC	6	1630	200	150	615	535	460	13	6	23	94	94	94	636	360	1370	2.540	
37	250SC	6	1700	200	150	650	585	505	13	6	23	94	94	77	636	510	1562	2.614	
45	250MC	6	1700	200	150	650	585	505	13	6	23	94	94	115	636	565	1617	2.667	

Performance curves

HS 300-250-381
6-pole

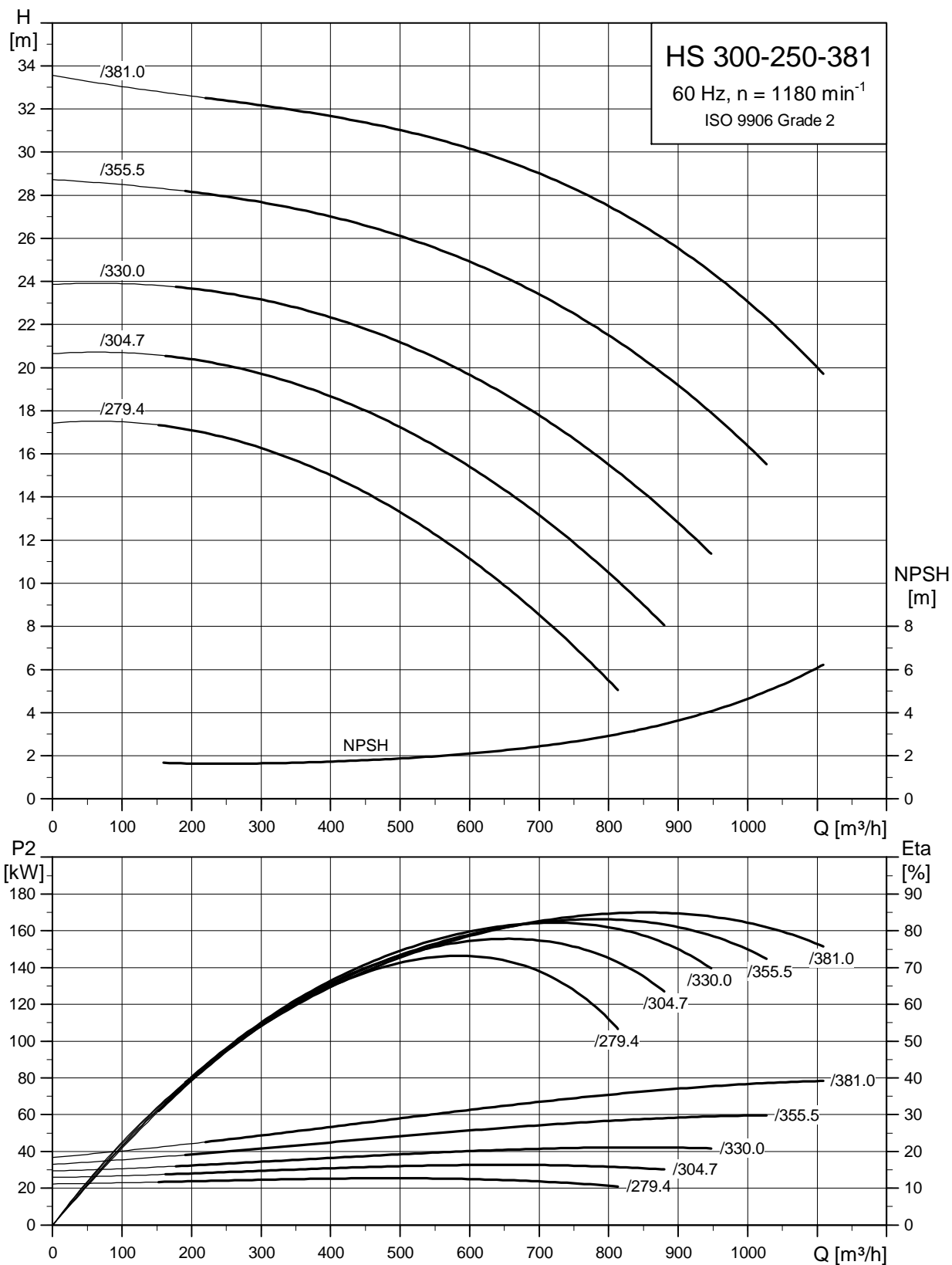

TM03 9871 4507

Dimensional sketch

HS extended, 300-250-381

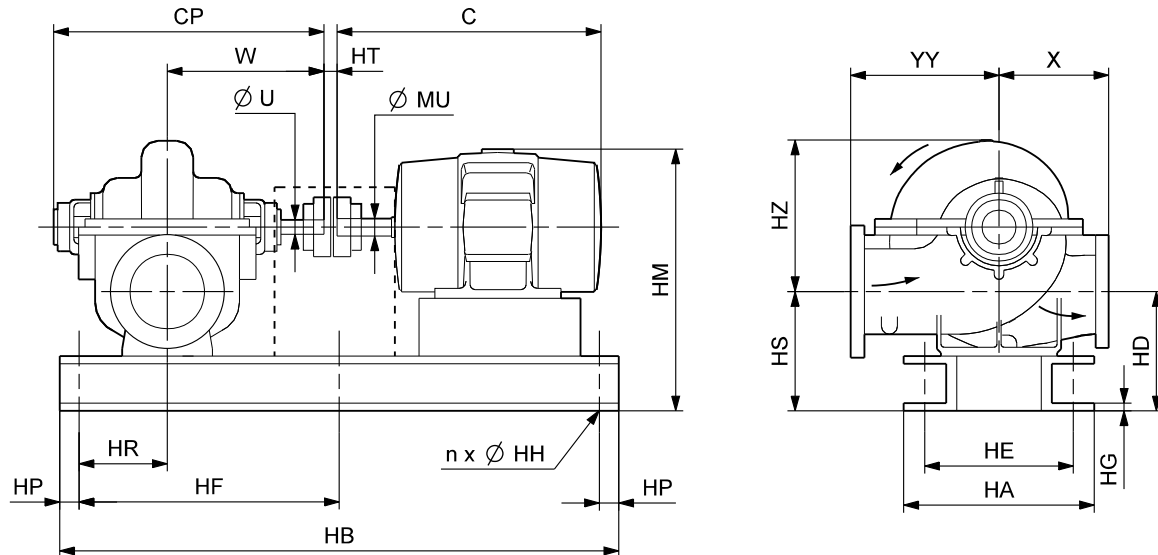

TM04 1828 1108

Dimensions

Motor			Pump dimensions [mm]									Motor dimensions [mm]			Distance between shaft ends [mm]
P ₂ [kW]	Frame size	Number of poles	CP		W	ØU	X	YY	HD	HS	HZ	C	HM	ØMU	HT
			Mechanical seal	Stuffing box											
30	225MC	6	1051	1051	600	57.15	432	584	534	534	630	841	1087	60	3.2
37	250SC	6	1051	1051	600	57.15	432	584	534	534	630	883	1113	70	3.2
45	250MC	6	1051	1051	600	57.15	432	584	534	534	630	921	1113	70	3.2
55	280SB	6	1051	1051	600	57.15	432	584	534	534	630	1026	1168	80	3.2
75	280MB	6	1051	1051	600	57.15	432	584	534	534	630	1077	1168	80	3.2
90	315SB	6	1051	1051	600	57.15	432	584	534	534	630	1116	1216	85	3.2

Motor			Base frame dimensions [mm]									Overhang [mm]			Net weights [kg]			Shipping volume [m ³]
P ₂ [kW]	Frame size	Number of poles	HB	HP	HR	HF	HA	HE	HG	n	ØHH	Pump end		Motor end	Pump	Motor	Total	
												Mechanical seal	Stuffing box					
30	225MC	6	1630	200	80	615	600	510	13	6	23	171	171	94	991	360	1749	3.222
37	250SC	6	1690	200	80	645	585	510	13	6	23	171	171	76	991	510	1917	3.293
45	250MC	6	1690	200	80	645	585	510	13	6	23	171	171	114	991	565	1972	3.357
55	280SB	6	1820	200	80	710	645	575	13	6	23	171	171	89	991	650	2097	3.549
75	280MB	6	1820	200	80	710	645	575	13	6	23	171	171	140	991	730	2177	3.636
90	315SB	6	1890	200	80	745	720	640	13	6	23	171	171	109	991	920	2398	3.854

Performance curves

HS 350-250-498
6-pole

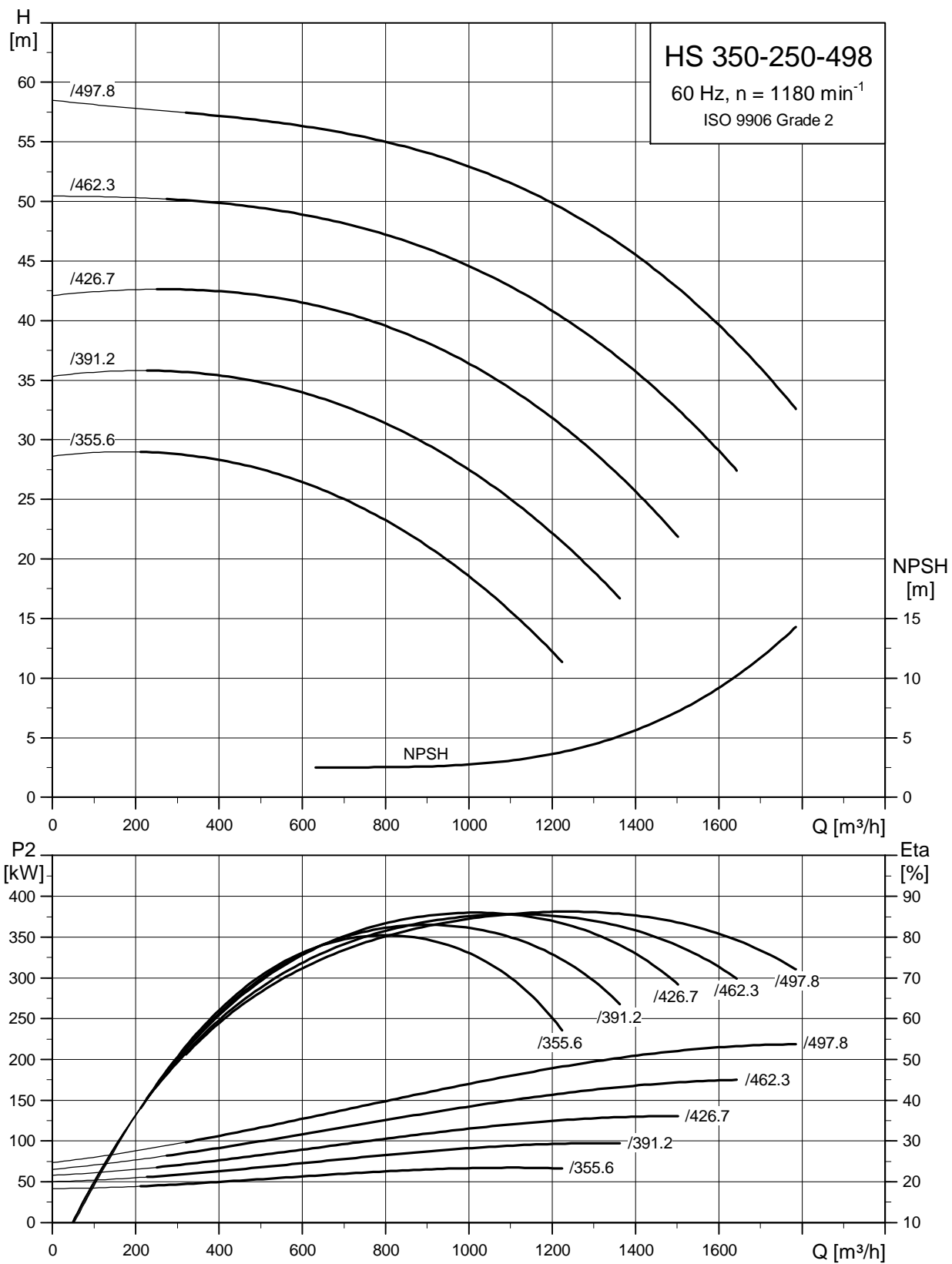

TM03 9873 4507

Dimensional sketch

HS extended, 350-250-498

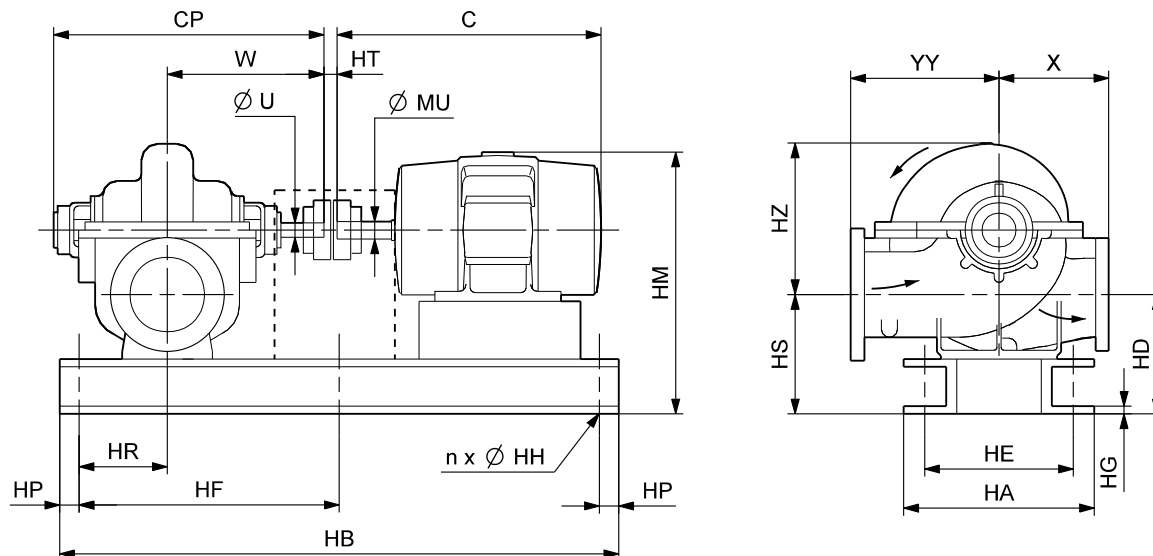

TM04 1828 1108

Dimensions

Motor			Pump dimensions [mm]							Motor dimensions [mm]			Distance between shaft ends [mm]		
P ₂ [kW]	Frame size	Number of poles	CP		W	Ø U	X	YY	HD	HS	HZ	C	HM	Ø MU	HT
			Mechanical seal	Stuffing box											
75	280MB	6	1403	1403	797	79.38	508	660	526	526	785	1077	1246	80	3.2
90	315SB	6	1403	1403	797	79.38	508	660	526	526	785	1116	1294	85	3.2
110	315MB	6	1403	1403	797	79.38	508	660	526	526	785	1167	1294	85	3.2
132	315MB	6	1403	1403	797	79.38	508	660	526	526	785	1167	1294	85	3.2
160	315CB	6	1403	1403	797	79.38	508	660	526	526	785	1646	1425	95	3.2
200	315CB	6	1403	1403	797	79.38	508	660	526	526	785	1646	1425	95	3.2
220	315CB	6	1403	1403	797	79.38	508	660	526	526	785	1646	1425	95	3.2
250	315DB	6	1403	1403	797	79.38	508	660	526	526	785	1848	1425	95	3.2

Motor			Base frame dimensions [mm]										Overhang [mm]			Net weights [kg]			Shipping volume [m ³]
P ₂ [kW]	Frame size	Number of poles	HB	HP	HR	HF	HA	HE	HG	n	Ø HH	Pump end		Motor end	Pump	Motor	Total		
												Mechanical seal	Stuffing box						
75	280MB	6	2090	200	150	845	703	625	13	6	23	256	256	137	1436	730	2716	5.375	
90	315SB	6	2160	200	150	880	720	650	13	6	23	256	256	106	1436	920	2818	5.460	
110	315MB	6	2160	200	150	880	720	650	13	6	23	256	256	157	1436	1020	2918	5.570	
132	315MB	6	2160	200	150	880	720	650	13	6	23	256	256	157	1436	1040	2938	5.570	
160	315CB	6	2650	200	150	1125	735	655	13	6	23	256	256	146	1436	1600	3768	7.210	
200	315CB	6	2650	200	150	1125	735	655	13	6	23	256	256	146	1436	1780	3948	7.210	
220	315CB	6	2650	200	150	1125	735	655	13	6	23	256	256	146	1436	1800	3968	7.210	
250	315DB	6	2650	200	150	1125	735	655	13	6	23	256	256	348	1436	1950	4118	7.687	

Performance curves

HS 350-250-630
6-pole

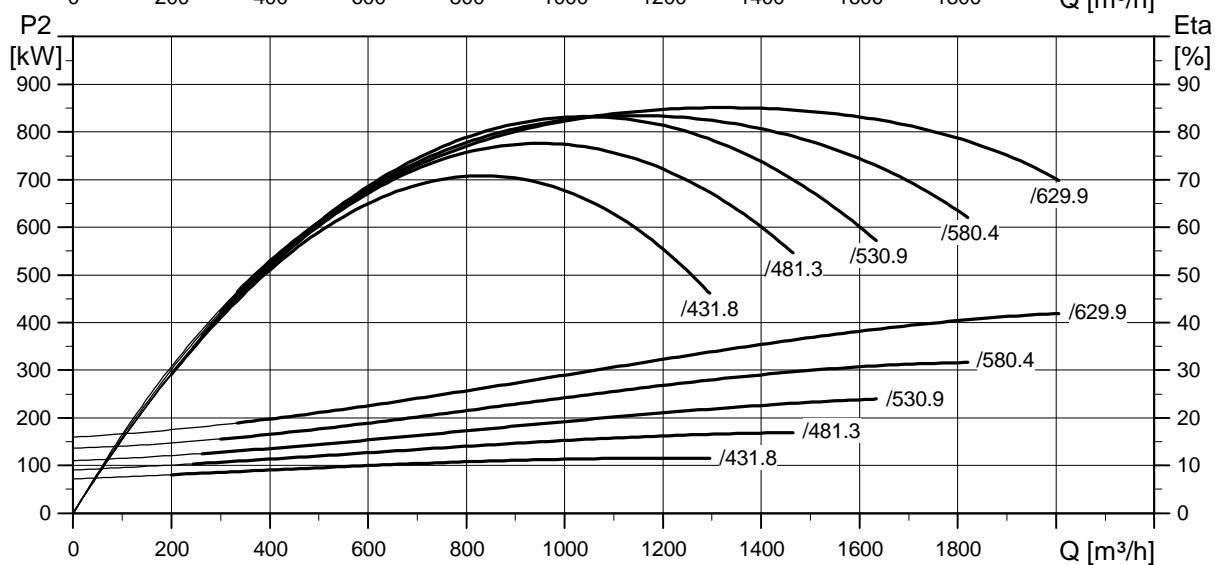
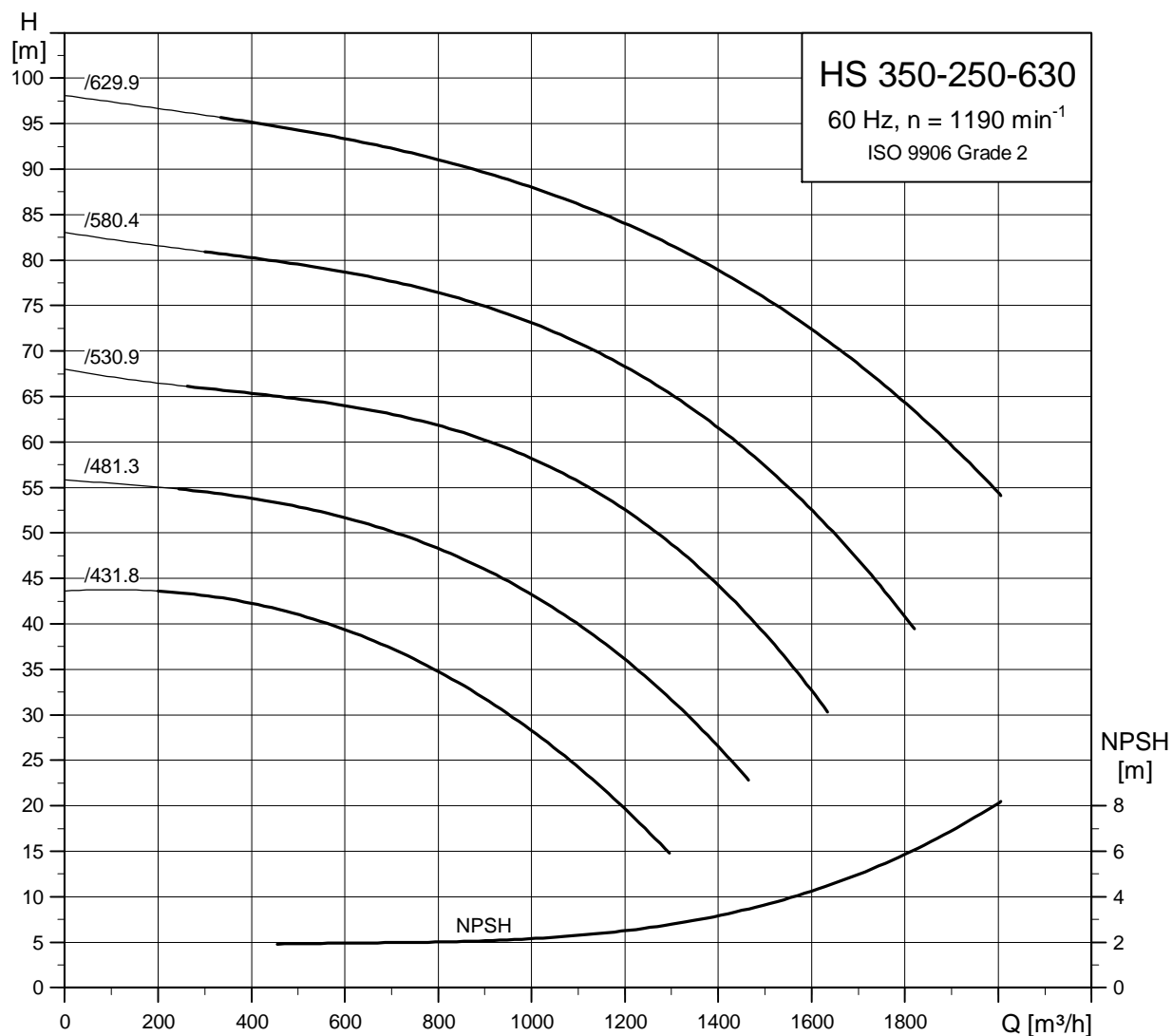

TM03 9875 4507

Dimensional sketch

HS extended, 350-250-630

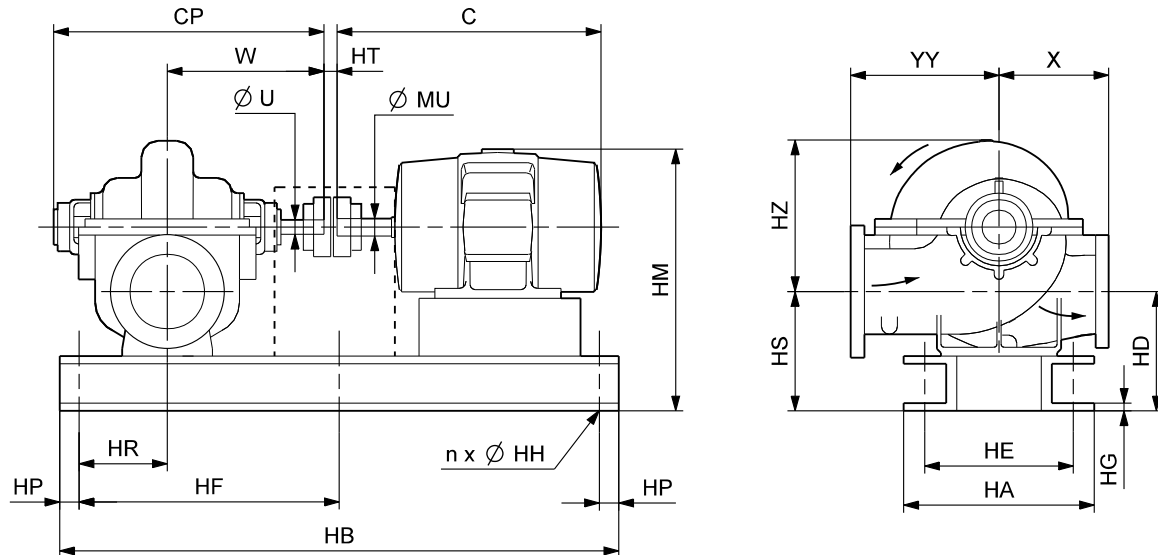

TM04 1828 1108

Dimensions

Motor			Pump dimensions [mm]									Motor dimensions [mm]			Distance between shaft ends [mm]
P ₂ [kW]	Frame size	Number of poles	CP		W	ØU	X	YY	HD	HS	HZ	C	HM	ØMU	HT
			Mechanical seal	Stuffing box											
132	315MB	6	1377	1377	799	79.38	610	711	585	585	820	1167	1343	85	3.2
160	315CB	6	1377	1377	799	79.38	610	711	585	585	820	1646	1474	95	3.2
200	315CB	6	1377	1377	799	79.38	610	711	585	585	820	1646	1474	95	3.2
220	315CB	6	1377	1377	799	79.38	610	711	585	585	820	1646	1474	95	3.2
250	315DB	6	1377	1377	799	79.38	610	711	585	585	820	1848	1474	95	3.2
300	355AB	6	1377	1377	799	79.38	610	711	585	585	820	1749	1557	95	3.2
315	355CB	6	1377	1377	799	79.38	610	711	585	585	820	1939	1557	95	3.2
335	355CB	6	1377	1377	799	79.38	610	711	585	585	820	1939	1557	95	3.2
355	400AB	6	1377	1377	799	79.38	610	711	585	585	820	1925	1577	110	4.8
375	400AB	6	1377	1377	799	79.38	610	711	585	585	820	1925	1577	110	4.8
450	400AB	6	1377	1377	799	79.38	610	711	585	585	820	1925	1577	110	4.8

Motor			Base frame dimensions [mm]										Overhang [mm]			Net weights [kg]			Shipping volume [m ³]
P ₂ [kW]	Frame size	Number of poles	HB	HP	HR	HF	HA	HE	HG	n	ØHH	Pump end		Motor end	Pump	Motor	Total		
												Mechanical seal	Stuffing box						
132	315MB	6	2160	200	150	880	720	640	13	6	23	228	228	159	1905	1040	3541	6.361	
160	315CB	6	2650	200	150	1125	735	665	13	6	23	228	228	148	1905	1600	4271	7.930	
200	315CB	6	2650	200	150	1125	735	665	13	6	23	228	228	148	1905	1780	4451	7.930	
220	315CB	6	2650	200	150	1125	735	665	13	6	23	228	228	148	1905	1800	4471	7.930	
250	315DB	6	2650	200	150	1125	735	665	13	6	23	228	228	350	1905	1950	4621	8.459	
300	355AB	6	2710	200	150	1155	835	745	13	6	23	228	228	191	1905	2150	4911	8.971	
315	355CB	6	2710	200	150	1155	835	745	13	6	23	228	228	381	1905	2500	5261	9.516	
335	355CB	6	2710	200	150	1155	835	745	13	6	23	228	228	381	1905	2500	5261	9.516	
355	400AB	6	2890	200	150	1245	895	810	13	6	23	228	228	188	1905	3000	5810	9.680	
375	400AB	6	2890	200	150	1245	895	810	13	6	23	228	228	188	1905	3000	5810	9.680	
450	400AB	6	2890	200	150	1245	895	810	13	6	23	228	228	188	1905	3000	5810	9.680	

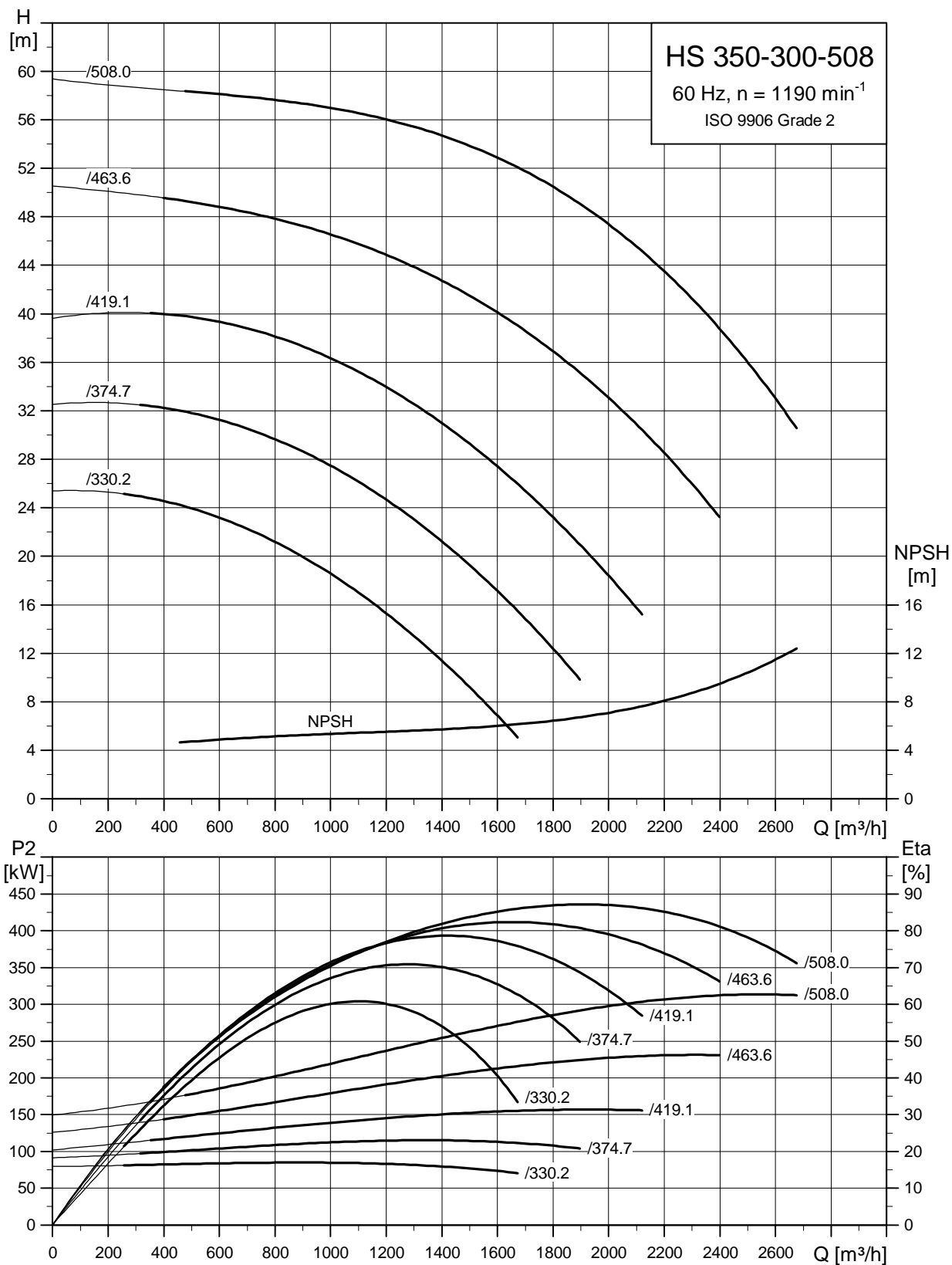

TM03 9876 4507

Dimensional sketch

HS extended, 350-300-508

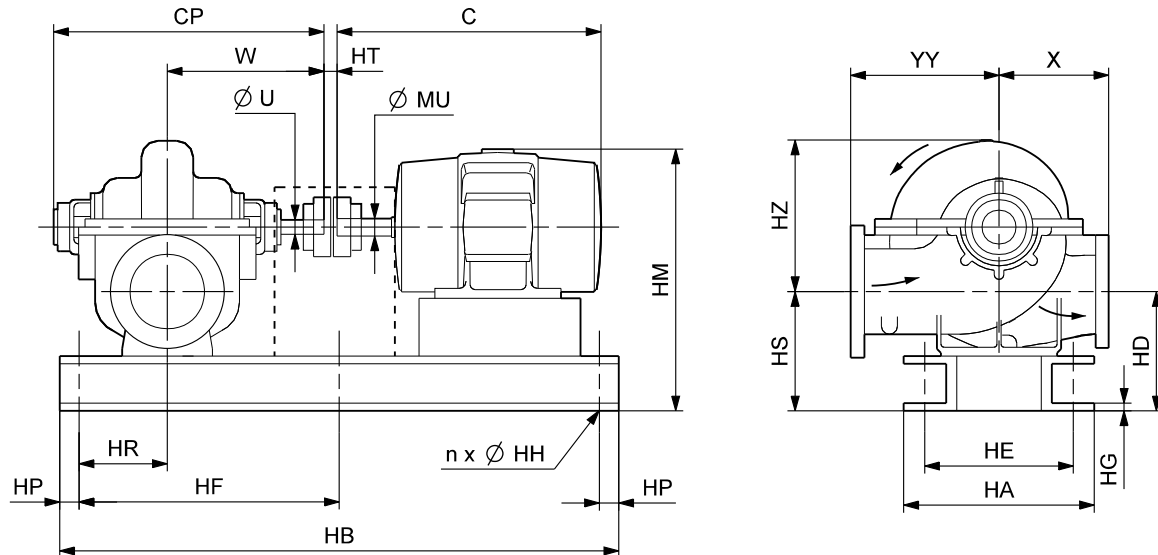

TM04 1828 1108

Dimensions

Motor			Pump dimensions [mm]									Motor dimensions [mm]			Distance between shaft ends [mm]
P ₂ [kW]	Frame size	Number of poles	CP		W	Ø U	X	YY	HD	HS	HZ	C	HM	Ø MU	HT
			Mechanical seal	Stuffing box											
90	315SB	6	1377	1377	749	63.50	584	711	592	592	790	1116	1351	85	3.2
110	315MB	6	1377	1377	749	63.50	584	711	592	592	790	1167	1351	85	3.2
132	315MB	6	1377	1377	749	63.50	584	711	592	592	790	1167	1351	85	3.2
160	315CB	6	1377	1377	749	63.50	584	711	592	592	790	1646	1482	95	3.2
200	315CB	6	1377	1377	749	63.50	584	711	592	592	790	1646	1482	95	3.2
220	315CB	6	1377	1377	749	63.50	584	711	592	592	790	1646	1482	95	3.2
250	315DB	6	1377	1377	749	63.50	584	711	592	592	790	1848	1482	95	3.2
300	355AB	6	1377	1377	749	63.50	584	711	592	592	790	1749	1565	95	3.2
315	355CB	6	1377	1377	749	63.50	584	711	592	592	790	1939	1565	95	3.2
335	355CB	6	1377	1377	749	63.50	584	711	592	592	790	1939	1565	95	3.2
355	400AB	6	1377	1377	749	63.50	584	711	592	592	790	1925	1585	110	19.9

Motor			Base frame dimensions [mm]										Overhang [mm]			Net weights [kg]			Shipping volume [m ³]
P ₂ [kW]	Frame size	Number of poles	HB	HP	HR	HF	HA	HE	HG	n	Ø HH	Pump end		Motor end	Pump	Motor	Total		
												Mechanical seal	Stuffing box						
												90	315SB					6	2110
110	315MB	6	2110	200	150	855	720	630	13	6	23	278	278	160	1318	1020	2940	6.262	
132	315MB	6	2110	200	150	855	720	630	13	6	23	278	278	160	1318	1040	2960	6.262	
160	315CB	6	2600	200	150	1100	735	650	13	6	23	278	278	149	1318	1600	3613	7.973	
200	315CB	6	2600	200	150	1100	735	650	13	6	23	278	278	149	1318	1780	3793	7.973	
220	315CB	6	2600	200	150	1100	735	650	13	6	23	278	278	149	1318	1800	3813	7.973	
250	315DB	6	2600	200	150	1100	735	650	13	6	23	278	278	351	1318	1950	3963	8.505	
300	355AB	6	2660	200	150	1130	835	765	13	6	23	278	278	192	1318	2150	4265	9.017	
315	355CB	6	2660	200	150	1130	835	765	13	6	23	278	278	382	1318	2500	4615	9.564	
335	355CB	6	2660	200	150	1130	835	765	13	6	23	278	278	382	1318	2500	4615	9.564	
355	400AB	6	2660	200	150	1130	895	810	13	6	23	278	278	384	1318	3000	5174	9.774	

Performance curves

HS 400-350-397
6-pole

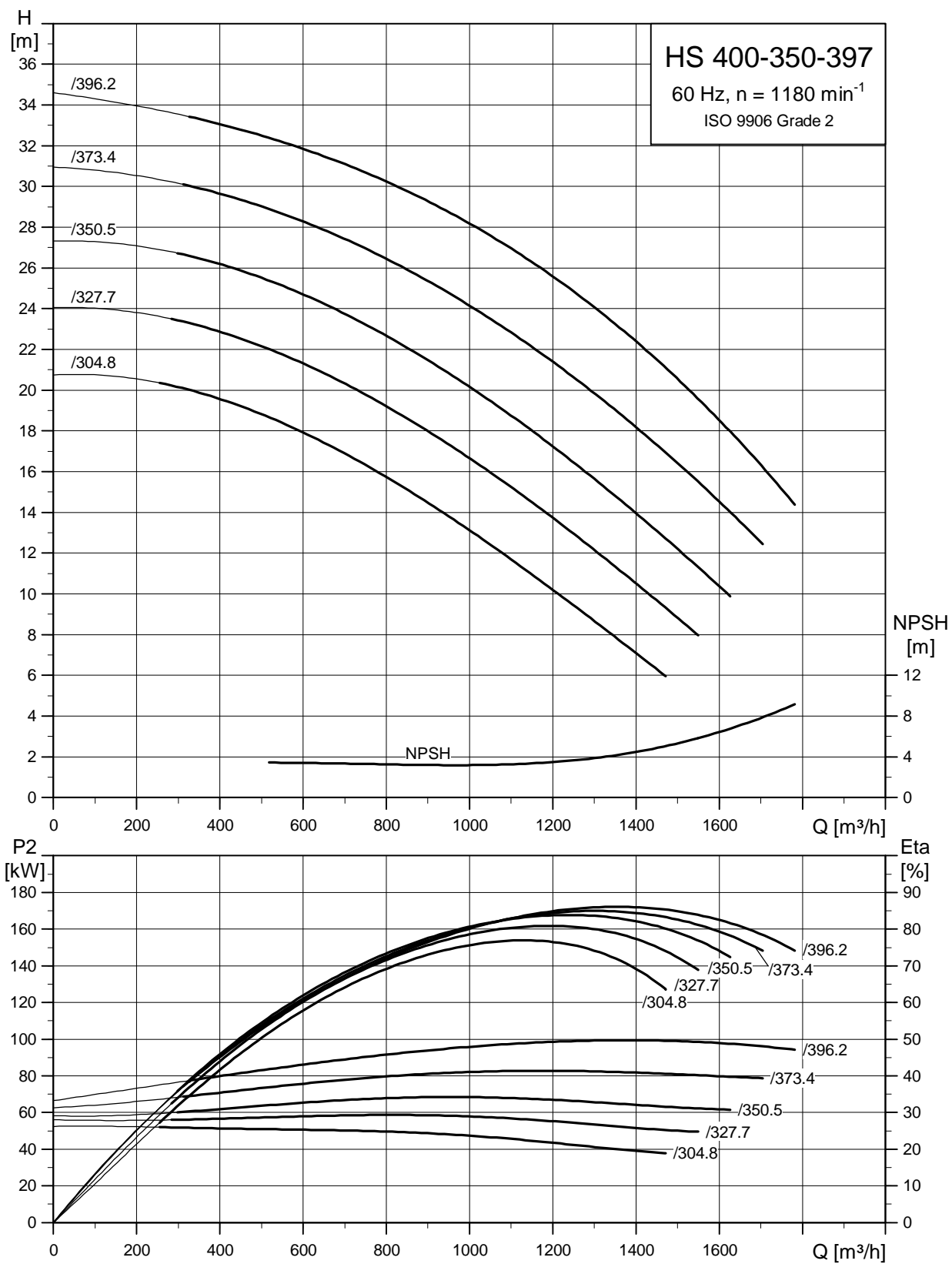

TM03 9878 4507

Dimensional sketch

HS extended, 400-350-397

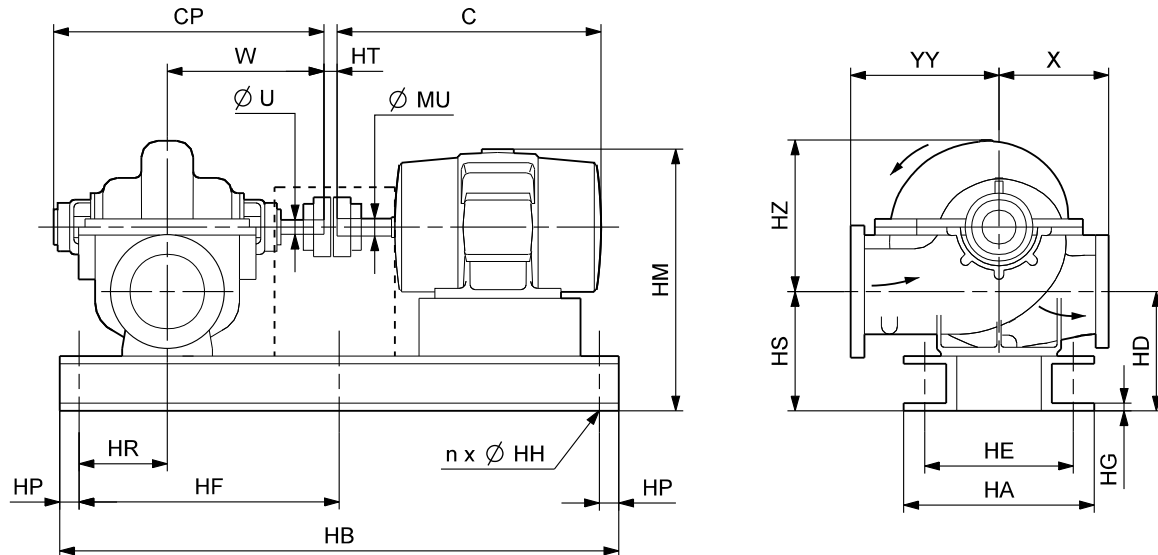

TM04 1828 1108

Dimensions

Motor			Pump dimensions [mm]								Motor dimensions [mm]			Distance between shaft ends [mm]	
P ₂ [kW]	Frame size	Number of poles	CP		W	ØU	X	YY	HD	HS	HZ	C	HM	ØMU	HT
			Mechanical seal	Stuffing box											
55	280SB	6	1299	1299	723	63.50	550	650	600	600	800	1026	1330	80	3.2
75	280MB	6	1299	1299	723	63.50	550	650	600	600	800	1077	1330	80	3.2
90	315SB	6	1299	1299	723	63.50	550	650	600	600	800	1116	1378	85	3.2
110	315MB	6	1299	1299	723	63.50	550	650	600	600	800	1167	1378	85	3.2

Motor			Base frame dimensions [mm]									Overhang [mm]			Net weights [kg]			Shipping volume [m ³]
P ₂ [kW]	Frame size	Number of poles	HB	HP	HR	HF	HA	HE	HG	n	ØHH	Pump end		Motor end	Pump	Motor	Total	
												Mechanical seal	Stuffing box					
55	280SB	6	2090	200	230	845	845	760	13	6	23	146	146	92	1460	650	2756	5.297
75	280MB	6	2090	200	230	845	845	760	13	6	23	146	146	143	1460	730	2836	5.413
90	315SB	6	2160	200	230	880	845	775	13	6	23	146	146	112	1460	920	3038	5.502
110	315MB	6	2160	200	230	880	845	775	13	6	23	146	146	163	1460	1020	3138	5.618

Dimensional sketch

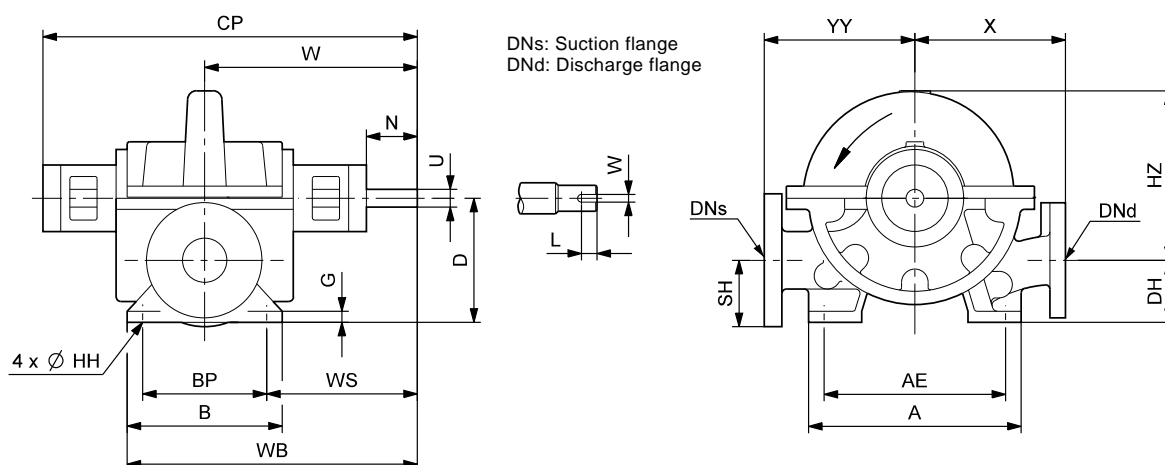

TM04 1827 1108

Dimensions

All dimensions are in mm, except for those which have necessary inch tolerances (1 inch = 25.4 mm). For actual pump flange dimensions, see page 114-115. For counter-flange dimensions, see page 118.

Pump size	DNs	DNd	A	AE	B	BP	CP		D	DH	G	ØHH	HZ	Key (WxL)	
							Sealed	Packed						[inch]	[mm]
							HS65-50-242	65						50	305
HS65-50-331	65	50	305	260	222	178	510	545	216	89	16	19	355	0.25x2.12	6.35x53.85
HS100-80-242 ¹⁾	100	80	305	260	222	178	510	545	203	102	19	19	290	0.25x2.12	6.35x53.85
HS100-80-242 ²⁾	100	80	305	260	222	178	510	545	203	102	19	19	290	0.25x2.12	6.35x53.85
HS100-80-356	100	80	305	260	279	235	644	687	254	127	22	19	380	0.38x2.25	9.65x57.15
HS125-100-280	125	100	305	260	283	235	631	674	257	124	22	19	370	0.38x2.25	9.65x57.15
HS125-100-305	125	100	305	260	283	235	631	674	257	124	22	19	370	0.38x2.25	9.65x57.15
HS125-100-381	125	100	305	260	349	305	631	674	330	159	25	19	470	0.38x2.25	9.65x57.15
HS150-125-305	150	125	305	260	305	260	775	775	368	165	25	19	475	0.38x2.25	9.65x57.15
HS150-125-381	150	125	305	260	305	260	801	801	410	165	25	19	550	0.38x2.25	9.65x57.15
HS200-150-305A	200	150	305	260	305	260	656	699	330	165	25	19	430	0.38x2.25	9.65x57.15
HS200-150-305C	200	150	305	260	305	260	801	801	406	165	25	19	530	0.38x2.25	9.65x57.15
HS200-150-381	200	150	311	260	457	419	929	929	464	184	29	19	605	0.38x2.25	9.65x57.15
HS200-150-483 ³⁾	200	150	305	260	356	305	888	888	432	171	25	19	615	0.38x2.31	9.65x57.74
HS200-150-483 ⁴⁾	200	150	305	260	356	305	899	899	432	171	25	19	615	0.38x3.00	9.65x76.20
HS200-150-508	200	150	318	260	356	305	995	995	451	171	25	19	660	0.50x3.00	12.70x76.20
HS250-200-305	250	200	305	260	394	356	929	929	438	171	29	19	580	0.38x2.25	9.65x57.15
HS250-200-381	250	200	324	260	495	445	949	949	483	178	29	19	655	0.38x2.25	9.65x57.15
HS300-200-489	300	200	648	502	489	406	1306	1306	529	198	35	29	745	0.63x3.00	16.00x76.20
HS300-250-305	300	250	324	260	495	445	974	974	503	203	29	19	645	0.38x2.25	9.65x57.15
HS300-250-381	300	250	457	381	356	305	1051	1051	508	254	29	22	630	0.50x2.75	12.70x69.85
HS350-250-498	350	250	648	502	489	406	1403	1403	586	246	35	29	785	0.75x4.75	19.05x120.65
HS350-250-630	350	250	648	502	489	406	1377	1377	635	305	35	29	820	0.75x4.75	19.05x120.65
HS350-300-508	350	300	648	502	489	406	1377	1377	643	313	35	29	790	0.63x3.00	16.00x76.20
HS400-350-397	400	350	790	610	657	575	1299	1299	670	320	40	23	800	0.63x3.00	16.00x76.20

¹⁾ Shaft load up to 1.27 kW/100 rpm
²⁾ Shaft load above 1.27 kW/100 rpm
³⁾ Shaft load up to 2.7 kW/100 rpm
⁴⁾ Shaft load above 2.7 kW/100 rpm.

Dimensional sketch

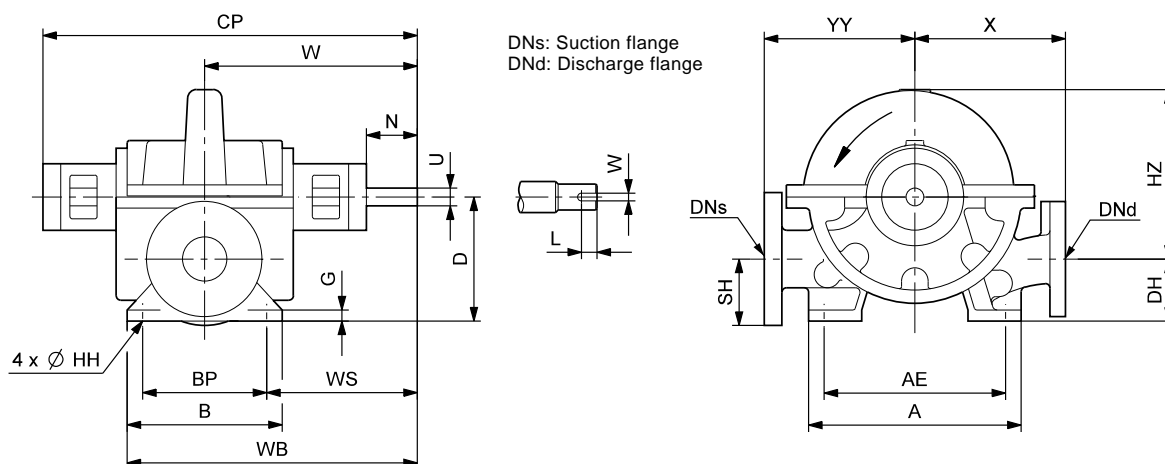

TM04 1827 1108

Dimensions

All dimensions are in mm, except for those which have necessary inch tolerances (1 inch = 25.4 mm). For actual pump flange dimensions, see page 114-115. For counter-flange dimensions, see page 118.

Pump size	DNs	DNd	N		SH	U		W	WB	WS	X	YY	Net weight [kg]
			Sealed	Packed		[inch]	[mm]						
HS65-50-242	65	50	100	65	89	1.00	25.40	305	416	216	216	216	73
HS65-50-331	65	50	100	65	89	1.00	25.40	305	416	216	254	254	95
HS100-80-242 ¹⁾	100	80	100	65	102	1.00	25.40	305	416	216	279	279	80
HS100-80-242 ²⁾	100	80	100	65	102	1.19	30.16	305	416	216	279	279	80
HS100-80-356	100	80	118	75	127	1.50	38.10	368	508	251	305	305	177
HS125-100-280	125	100	106	63	124	1.50	38.10	368	508	251	305	305	164
HS125-100-305	125	100	106	63	124	1.50	38.10	368	508	251	305	305	164
HS125-100-381	125	100	106	63	159	1.50	38.10	368	543	216	357	357	255
HS150-125-305	150	125	63	63	165	1.50	38.10	419	572	289	330	330	268
HS150-125-381	150	125	63	63	165	1.50	38.10	432	584	302	356	381	318
HS200-150-305A	200	150	105	63	165	1.50	38.10	381	533	251	279	330	255
HS200-150-305C	200	150	63	63	165	1.50	38.10	432	584	302	356	406	411
HS200-150-381	200	150	87	87	184	1.75	44.45	508	737	298	381	406	455
HS200-150-483 ³⁾	200	150	90	90	171	1.75	44.45	489	667	337	432	432	534
HS200-150-483 ⁴⁾	200	150	85	85	171	2.00	50.80	489	667	337	432	432	534
HS200-150-508	200	150	98	98	171	2.13	53.98	546	724	394	432	483	545
HS250-200-305	250	200	87	87	171	1.75	44.45	508	705	330	406	432	511
HS250-200-381	250	200	87	87	178	1.75	44.45	518	765	295	483	483	568
HS300-200-489	300	200	147	147	198	2.50	63.50	723	994	519	414	559	727
HS300-250-305	300	250	87	87	203	1.75	44.45	530	778	308	495	495	636
HS300-250-381	300	250	149	149	254	2.25	57.15	600	778	448	432	584	991
HS350-250-498	350	250	205	205	246	3.13	79.38	797	1049	594	508	660	1436
HS350-250-630	350	250	219	219	305	3.13	79.38	799	1049	594	610	711	1905
HS350-300-508	350	300	121	121	313	2.50	63.50	749	994	546	584	711	1318
HS400-350-397	400	350	142	147	320	2.50	63.50	723	1052	436	550	650	1460

¹⁾ Shaft load up to 1.27 kW/100 rpm

²⁾ Shaft load above 1.27 kW/100 rpm

³⁾ Shaft load up to 2.7 kW/100 rpm

⁴⁾ Shaft load above 2.7 kW/100 rpm.

Standard pump flange dimensions

PN 16

Some pump flanges have tapped holes due to the pump construction.

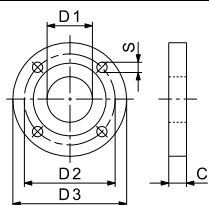

TM04 4474 1309

EN 1092-2 (DIN 2501)
PN 16

Pump type	Flange size	Dimensions [mm]						Number of free holes (FH)	Number of tapped holes (TH)
		D1	D2	D3	C	S _{FH}	S _{TH}		
HS65-50-242	DNs 65	76.2	145	191	25.4	18	-	4	-
	DNd 50	50.8	125	165	22.2	18	-	4	-
HS65-50-331	DNs 65	76.2	145	191	25.4	18	-	4	-
	DNd 50	50.8	125	165	22.2	18	-	4	-
HS100-80-242	DNs 100	102	180	254	31.8	18	-	8	-
	DNd 80	76.2	160	210	28.6	18	-	8	-
HS100-80-356	DNs 100	102	180	254	31.8	18	-	8	-
	DNd 80	76.2	160	210	28.6	18	-	8	-
HS125-100-280	DNs 125	127	210	279	34.9	18	-	8	-
	DNd 100	102	180	254	31.8	18	-	8	-
HS125-100-305	DNs 125	127	210	279	34.9	18	-	8	-
	DNd 100	102	180	254	31.8	18	-	8	-
HS125-100-381	DNs 125	127	210	279	34.9	18	-	8	-
	DNd 100	102	180	254	31.8	18	-	8	-
HS150-125-305	DNs 150	152	240	318	36.5	22	M20	6	2
	DNd 125	127	210	279	34.9	18	-	8	-
HS150-125-381	DNs 150	152	240	318	36.5	22	-	8	-
	DNd 125	127	210	279	34.9	18	-	8	-
HS200-150-305A	DNs 200	178	295	381	41.3	22	M20	10	2
	DNd 150	152	240	318	36.5	22	-	8	-
HS200-150-305C	DNs 200	178	295	381	41.3	22	M20	10	2
	DNd 150	152	240	318	36.5	22	-	8	-
HS200-150-381	DNs 200	178	295	381	41.3	22	M20	8	4
	DNd 150	152	240	318	36.5	22	-	8	-
HS200-150-483	DNs 200	178	295	381	41.4	-	M20	-	12
	DNd 150	152	240	318	36.6	22	-	4	4
HS200-150-508	DNs 200	178	295	381	41.3	22	M20	8	4
	DNd 150	152	240	317	36.5	22	-	8	-
HS250-200-305	DNs 250	229	355	445	47.6	-	M24	-	12
	DNd 200	203	295	381	41.3	22	M20	8	4
HS250-200-381	DNs 250	229	355	445	47.8	26	-	12	-
	DNd 200	203	295	381	41.4	22	-	12	-
HS300-200-489	DNs 300	229	410	521	50.8	26	-	12	-
	DNd 200	203	295	381	41.3	22	-	12	-
HS300-250-305	DNs 300	279	410	521	50.8	26	M24	10	2
	DNd 250	254	355	445	47.6	26	-	12	-
HS300-250-381	DNs 300	279	410	521	50.8	26	M24	8	4
	DNd 250	254	355	445	47.6	26	-	12	-
HS350-250-498	DNs 350	279	470	584	53.9	26	-	16	-
	DNd 250	254	355	445	47.6	26	-	12	-
HS350-250-630	DNs 350	279	470	584	54.0	26	-	16	-
	DNd 250	254	355	445	47.6	-	M24	-	12
HS350-300-508	DNs 350	330	470	584	54.0	26	-	16	-
	DNd 300	305	410	521	50.8	26	-	12	-
HS400-350-397	DNs 400	400	525	648	50.0	-	M27	-	16
	DNd 350	350	470	584	45.0	28	-	16	-

Optional pump flange dimensions

PN 10

Some pump flanges have tapped holes due to the pump construction.

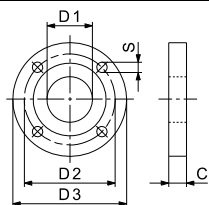

TM04 4474 1309

EN 1092-2 (DIN 2501)
PN 10

Pump type	Flange size	Dimensions [mm]						Number of free holes (FH)	Number of tapped holes (TH)
		D1	D2	D3	C	S _{FH}	S _{TH}		
HS65-50-242	DNs 65	76.2	145	191	25.4	18	-	4	-
	DNd 50	50.8	125	165	22.2	18	-	4	-
HS65-50-331	DNs 65	76.2	145	191	25.4	18	-	4	-
	DNd 50	50.8	125	165	22.2	18	-	4	-
HS100-80-242	DNs 100	102	180	254	31.8	18	-	8	-
	DNd 80	76.2	160	210	28.6	18	-	8	-
HS100-80-356	DNs 100	102	180	254	31.8	18	-	8	-
	DNd 80	76.2	160	210	28.6	18	-	8	-
HS125-100-280	DNs 125	127	210	279	34.9	18	-	8	-
	DNd 100	102	180	254	31.8	18	-	8	-
HS125-100-305	DNs 125	127	210	279	34.9	18	-	8	-
	DNd 100	102	180	254	31.8	18	-	8	-
HS125-100-381	DNs 125	127	210	279	34.9	18	-	8	-
	DNd 100	102	180	254	31.8	18	-	8	-
HS150-125-305	DNs 150	152	240	318	36.5	22	M20	6	2
	DNd 125	127	210	279	34.9	18	-	8	-
HS150-125-381	DNs 150	152	240	318	36.5	22	-	8	-
	DNd 125	127	210	279	34.9	18	-	8	-
HS200-150-305A	DNs 200	178	295	381	41.3	22	-	8	-
	DNd 150	152	240	318	36.5	22	-	8	-
HS200-150-305C	DNs 200	178	295	381	41.3	22	-	8	-
	DNd 150	152	240	318	36.5	22	-	8	-
HS200-150-381	DNs 200	178	295	381	41.3	22	-	8	-
	DNd 150	152	240	318	36.5	22	-	8	-
HS200-150-483	DNs 200	178	295	381	41.4	-	M20	-	8
	DNd 150	152	240	318	36.6	22	M20	4	4
HS200-150-508	DNs 200	178	295	381	41.3	22	M20	4	4
	DNd 150	152	240	318	36.5	22	-	8	-
HS250-200-305	DNs 250	229	350	445	47.6	-	M20	-	12
	DNd 200	203	295	381	41.3	22	M20	4	4
HS250-200-381	DNs 250	229	350	445	47.8	22	-	12	-
	DNd 200	203	295	381	41.4	22	-	8	-
HS300-200-489	DNs 300	229	400	521	50.8	22	-	12	-
	DNd 200	203	295	381	41.3	22	-	8	-
HS300-250-305	DNs 300	279	400	521	50.8	22	M20	10	2
	DNd 250	254	350	445	47.6	22	-	12	-
HS300-250-381	DNs 300	279	400	521	50.8	22	M20	8	4
	DNd 250	254	350	445	47.6	22	-	12	-
HS350-250-498	DNs 350	279	460	584	53.9	22	-	16	-
	DNd 250	254	350	445	47.6	22	-	12	-
HS350-250-630	DNs 350	279	460	584	54.0	22	-	16	-
	DNd 250	254	350	445	47.6	-	M20	-	12
HS350-300-508	DNs 350	330	460	584	54.0	22	-	16	-
	DNd 300	305	400	521	50.8	22	-	12	-
HS400-350-397	DNs 400	400	515	648	50.0	-	M24	-	16
	DNd 350	350	460	584	45.0	23	-	16	-

ANSI 125

Some pump flanges have tapped holes due to the pump construction.

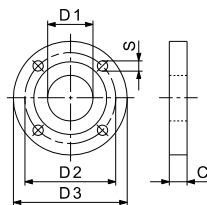

TM04 4474 1309

ANSI 125

Dimensions

Number of free holes (FH) Number of tapped holes (TH)

Pump type	Nominal pipe size	D1		D2		D3		C		S _{FH}		S _{TH}	Number of free holes (FH)	Number of tapped holes (TH)
		[mm]	[inch]	[mm]	[inch]	[mm]	[inch]	[mm]	[inch]	[mm]	[inch]			
HS65-50-242	NPSs 2½	76.2	3.0	140	5.50	191	7.50	25.4	1.00	19.1	0.75	-	4	-
	NPSd 2	50.8	2.0	121	4.75	165	6.50	22.2	0.88	19.1	0.75	-	4	-
HS65-50-331	NPSs 2½	76.2	3.0	140	5.50	191	7.50	25.4	1.00	19.1	0.75	-	4	-
	NPSd 2	50.8	2.0	121	4.75	165	6.50	22.2	0.88	19.1	0.75	-	4	-
HS100-80-242	NPSs 4	102	4.0	191	7.50	254	10.00	31.8	1.25	19.1	0.75	-	8	-
	NPSd 3	76.2	3.0	152	6.00	210	8.25	28.6	1.13	19.1	0.75	-	4	-
HS100-80-356	NPSs 4	102	4.0	191	7.50	254	10.00	31.8	1.25	-	-	5/8-11 UNC	-	8
	NPSd 3	76.2	3.0	152	6.00	210	8.25	28.6	1.13	19.1	0.75	-	4	-
HS125-100-280	NPSs 5	127	5.0	216	8.50	279	11.00	34.9	1.38	22.4	0.88	3/4-10 UNC	6	2
	NPSd 4	102	4.0	191	7.50	254	10.00	31.8	1.25	19.1	0.75	-	8	-
HS125-100-305	NPSs 5	127	5.0	216	8.50	279	11.00	34.9	1.38	22.4	0.88	3/4-10 UNC	6	2
	NPSd 4	102	4.0	191	7.50	254	10.00	31.8	1.25	19.1	0.75	-	8	-
HS125-100-381	NPSs 5	127	5.0	216	8.50	279	11.00	34.9	1.38	22.4	0.88	3/4-10 UNC	4	4
	NPSd 4	102	4.0	191	7.50	254	10.00	31.8	1.25	19.1	0.75	-	8	-
HS150-125-305	NPSs 6	152	6.0	241	9.50	318	12.50	36.5	1.44	-	-	3/4-10 UNC	-	8
	NPSd 5	127	5.0	216	8.50	279	11.00	34.9	1.38	22.4	0.88	-	8	-
HS150-125-381	NPSs 6	152	6.0	241	9.50	318	12.50	36.5	1.44	22.4	0.88	-	8	-
	NPSd 5	127	5.0	216	8.50	279	11.00	34.9	1.38	22.4	0.88	-	8	-
HS200-150-305A	NPSs 8	178	7.0	298	11.75	381	15.00	41.3	1.63	-	-	3/4-10 UNC	-	8
	NPSd 6	152	6.0	241	9.50	318	12.50	36.5	1.44	22.4	0.88	-	8	-
HS200-150-305C	NPSs 8	178	7.0	298	11.75	381	15.00	41.3	1.63	22.4	0.88	-	8	-
	NPSd 6	152	6.0	241	9.50	318	12.50	36.5	1.44	22.4	0.88	-	8	-
HS200-150-381	NPSs 8	178	7.0	298	11.75	381	15.00	41.3	1.63	22.4	0.88	3/4-10 UNC	4	4
	NPSd 6	152	6.0	241	9.50	318	12.50	36.5	1.44	22.4	0.88	-	8	-
HS200-150-483	NPSs 8	178	7.0	298	11.75	381	15.00	41.4	1.63	-	-	3/4-10 UNC	-	8
	NPSd 6	152	6.0	241	9.50	318	12.50	36.6	1.44	22.4	0.88	-	8	-
HS200-150-508	NPSs 8	178	7.0	298	11.75	381	15.00	41.3	1.63	22.4	0.88	-	8	-
	NPSd 6	152	6.0	241	9.50	318	12.50	36.5	1.44	22.4	0.88	-	8	-
HS250-200-305	NPSs 10	229	9.0	362	14.25	445	17.50	47.6	1.88	25.4	1.00	-	12	-
	NPSd 8	203	8.0	298	11.75	381	15.00	41.3	1.63	22.4	0.88	-	8	-
HS250-200-381	NPSs 10	229	9.0	362	14.25	445	17.50	47.8	1.88	25.4	1.00	-	12	-
	NPSd 8	203	8.0	298	11.75	381	15.00	41.4	1.63	22.4	0.88	-	8	-
HS300-200-489	NPSs 12	229	9.0	432	17.00	521	20.50	50.8	2.00	25.4	1.00	-	12	-
	NPSd 8	203	8.0	298	11.75	381	15.00	41.4	1.63	22.4	0.88	-	8	-
HS300-250-305	NPSs 12	279	11.0	432	17.00	521	20.50	50.8	2.00	25.4	1.00	-	12	-
	NPSd 10	254	10.0	362	14.25	445	17.50	47.6	1.88	25.4	1.00	-	12	-
HS300-250-381	NPSs 12	279	11.0	432	17.00	521	20.50	50.8	2.00	25.4	1.00	-	12	-
	NPSd 10	254	10.0	362	14.25	445	17.50	47.6	1.88	25.4	1.00	-	12	-
HS350-250-498	NPSs 14	279	11.0	476	18.75	584	23.00	53.9	2.12	28.5	1.12	-	12	-
	NPSd 10	254	10.0	362	14.25	445	17.50	47.6	1.88	25.4	1.00	-	12	-
HS350-250-630	NPSs 14	279	11.0	476	18.75	584	23.00	54.0	2.13	28.5	1.12	-	12	-
	NPSd 10	254	10.0	362	14.25	445	17.50	47.6	1.88	25.4	1.00	-	12	-
HS350-300-508	NPSs 14	330	13.0	476	18.75	584	23.00	54.0	2.13	28.5	1.12	-	12	-
	NPSd 12	305	12.0	432	17.00	521	20.50	50.8	2.00	25.4	1.00	-	12	-
HS400-350-397	NPSs 16	400	15.7	540	21.25	648	25.51	50.0	1.97	28.5	1.12	1-8 UNC	12	4
	NPSd 14	350	13.8	476	18.75	584	22.99	45.0	1.77	28.5	1.12	-	12	-

ANSI 250

Some pump flanges have tapped holes due to the pump construction.

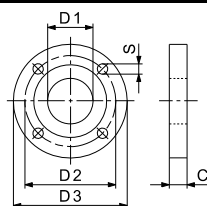

TM04 4474 1309

ANSI 250

Dimensions

Number of free holes (FH) Number of tapped holes (TH)

Pump type	Nominal pipe size	D1		D2		D3		C		S _{FH}		S _{TH}		
		[mm]	[inch]	[mm]	[inch]	[mm]	[inch]	[mm]	[inch]	[mm]	[inch]			
HS65-50-242	NPSs 2½	76.2	3.0	149	5.88	191	7.50	25.4	1.00	22.4	0.88	3/4-10 UNC	6	2
	NPSd 2	50.8	2.0	127	5.00	165	6.50	22.2	0.88	19.1	0.75	5/8-11 UNC	6	2
HS65-50-331	NPSs 2½	76.2	3.0	149	5.88	191	7.50	25.4	1.00	22.4	0.88	-	4	-
	NPSd 2	50.8	2.0	127	5.00	165	6.50	22.2	0.88	19.1	0.75	-	4	-
HS100-80-242	NPSs 4	102	4.0	200	7.88	254	10.00	31.8	1.25	22.4	0.88	-	8	-
	NPSd 3	76.2	3.0	168	6.62	210	8.25	28.6	1.13	22.4	0.88	-	8	-
HS100-80-356	NPSs 4	102	4.0	200	7.88	254	10.00	31.8	1.25	22.4	0.88	3/4-10 UNC	6	2
	NPSd 3	76.2	3.0	168	6.62	210	8.25	28.6	1.13	22.4	0.88	-	8	-
HS125-100-280	NPSs 5	127	5.0	235	9.25	279	11.00	34.4	1.35	22.4	0.88	3/4-10 UNC	6	2
	NPSd 4	102	4.0	200	7.88	254	10.00	31.8	1.25	22.4	0.88	-	8	-
HS125-100-305	NPSs 5	127	5.0	235	9.25	279	11.00	34.4	1.35	22.4	0.88	3/4-10 UNC	6	2
	NPSd 4	102	4.0	200	7.88	254	10.00	31.8	1.25	22.4	0.88	-	8	-
HS125-100-381	NPSs 5	127	5.0	235	9.25	279	11.00	34.9	1.38	22.4	0.88	3/4-10 UNC	4	4
	NPSd 4	102	4.0	200	7.88	254	10.00	31.8	1.25	22.4	0.88	-	8	-
HS150-125-305	NPSs 6	152	6.0	270	10.62	318	12.50	36.5	1.44	22.4	0.88	3/4-10 UNC	10	2
	NPSd 5	127	5.0	235	9.25	279	11.00	34.4	1.35	22.4	0.88	-	8	-
HS150-125-381	NPSs 6	152	6.0	270	10.62	318	12.50	36.5	1.44	22.4	0.88	-	12	-
	NPSd 5	127	5.0	235	9.25	279	11.00	34.4	1.35	22.4	0.88	-	8	-
HS200-150-305A	NPSs 8	178	7.0	330	13.00	381	15.00	41.3	1.63	25.4	1.00	7/8-9 UNC	10	2
	NPSd 6	152	6.0	270	10.62	318	12.50	36.5	1.44	22.4	0.88	3/4-10 UNC	10	2
HS200-150-305C	NPSs 8	178	7.0	330	13.00	381	15.00	41.3	1.63	25.4	1.00	-	12	-
	NPSd 6	152	6.0	270	10.62	318	12.50	36.5	1.44	22.4	0.88	-	12	-
HS200-150-381	NPSs 8	178	7.0	330	13.00	381	15.00	41.3	1.63	25.4	1.00	-	12	-
	NPSd 6	152	6.0	270	10.62	318	12.50	36.5	1.44	22.4	0.88	-	12	-
HS200-150-483	NPSs 8	178	7.0	330	13.00	381	15.00	41.4	1.63	-	-	7/8-9 UNC	-	12
	NPSd 6	152	6.0	270	10.62	318	12.50	36.6	1.44	22.4	0.88	-	12	-
HS200-150-508	NPSs 8	178	7.0	330	13.00	381	15.00	41.3	1.63	25.4	1.00	-	12	-
	NPSd 6	152	6.0	270	10.62	318	12.50	36.5	1.44	22.4	0.88	-	12	-
HS250-200-305	NPSs 10	229	9.0	387	15.25	445	17.50	47.6	1.88	28.6	1.13	1-8 UNC	12	4
	NPSd 8	203	8.0	330	13.00	381	15.00	41.3	1.63	25.4	1.00	7/8-9 UNC	8	4
HS250-200-381	NPSs 10	229	9.0	387	15.25	445	17.50	47.8	1.88	28.6	1.13	-	16	-
	NPSd 8	203	8.0	330	13.00	381	15.00	41.4	1.63	25.4	1.00	-	12	-
HS300-200-489	NPSs 12	229	9.0	451	17.75	521	20.50	50.8	2.00	31.8	1.25	-	16	-
	NPSd 8	203	8.0	330	13.00	381	15.00	41.4	1.63	25.4	1.00	-	12	-
HS300-250-305	NPSs 12	279	11.0	451	17.75	521	20.50	50.8	2.00	31.8	1.25	-	16	-
	NPSd 10	254	10.0	387	15.25	445	17.50	47.6	1.88	28.5	1.12	-	16	-
HS300-250-381	NPSs 12	279	11.0	451	17.75	521	20.50	50.8	2.00	31.8	1.25	-	16	-
	NPSd 10	254	10.0	387	15.25	445	17.50	47.6	1.88	28.5	1.12	-	16	-
HS350-250-498	NPSs 14	279	11.0	514	20.25	584	23.00	53.9	2.12	31.8	1.25	-	20	-
	NPSd 10	254	10.0	387	15.25	445	17.50	47.6	1.88	28.5	1.12	-	16	-
HS350-250-630	NPSs 14	279	11.0	514	20.25	584	23.00	54.0	2.13	31.8	1.25	-	20	-
	NPSd 10	254	10.0	387	15.25	445	17.50	47.6	1.88	28.5	1.12	-	16	-
HS350-300-508	NPSs 14	330	13.0	514	20.25	584	23.00	54.0	2.13	31.8	1.25	-	20	-
	NPSd 12	305	12.0	451	17.75	521	20.50	50.8	2.00	31.8	1.25	-	16	-
HS400-350-397	NPSs 16	400	15.7	572	22.50	648	25.51	50.0	1.97	35.1	1.38	1 1/8-7 UNC	16	4
	NPSd 14	350	13.8	514	20.25	584	22.99	45.0	1.77	31.8	1.25	1 1/8-7 UNC	16	4

Counter-flange dimensions

Following tables show standard dimensions for counter-flanges.

Counter-flanges to EN 1092-2 (DIN 2501), PN 16

(Ductile iron)

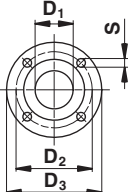

	Nominal flange diameter (DN)										
	[mm]										
	50	65	80	100	125	150	200	250	300	350	400
D1	50	65	80	100	125	150	200	250	300	350	400
D2	125	145	160	180	210	240	295	355	410	470	525
D3	165	185	200	220	250	285	340	400	455	520	580
S	4 x 19	4 x 19	8 x 19	8 x 19	8 x 19	8 x 23	12 x 23	12 x 28	12 x 28	16 x 28	16 x 31
Bolt size	M16	M16	M16	M16	M16	M20	M20	M24	M24	M24	M27

Counter-flanges to EN 1092-2 (DIN 2501), PN 10

(Cast iron)

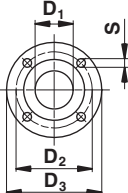

	Nominal flange diameter (DN)										
	[mm]										
	50	65	80	100	125	150	200	250	300	350	400
D1	50	65	80	100	125	150	200	250	300	350	400
D2	125	145	160	180	210	240	295	350	400	460	515
D3	165	185	200	220	250	285	340	395	445	505	565
S	4 x 19	4 x 19	8 x 19	8 x 19	8 x 19	8 x 23	8 x 23	12 x 23	12 x 23	16 x 23	16 x 28
Bolt size	M16	M16	M16	M16	M16	M20	M20	M20	M20	M20	M24

Counter-flanges to ANSI 125

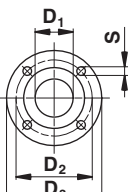

	Nominal flange diameter (NPS)											
	2	2½	3	4	5	6	8	10	12	14	16	
D1	[mm]	50.8	63.5	76.2	102	127	152	203	254	305	356	406
	[inch]	2	2.5	3	4	5	6	8	10	12	14	16
D2	[mm]	121	140	152	191	216	241	298	362	432	476	540
	[inch]	4.75	5.5	6	7.5	8.5	9.5	11.8	14.3	17	18.8	21.3
D3	[mm]	152	178	191	229	254	279	343	406	483	533	597
	[inch]	6	7	7.5	9	10	11	13.5	16	19	21	23.5
S	[mm]	4 x 19.1	4 x 19.1	4 x 19.1	8 x 19.1	8 x 22.4	8 x 22.4	8 x 22.4	12 x 25.4	12 x 25.4	12 x 28.5	16 x 28.5
	[inch]	4 x 0.75	4 x 0.75	4 x 0.75	8 x 0.75	8 x 0.88	8 x 0.88	8 x 0.88	12 x 1.00	12 x 1.00	12 x 1.12	16 x 1.12
Bolt size	5/8"	5/8"	5/8"	5/8"	3/4"	3/4"	3/4"	7/8"	7/8"	1"	1"	

Counter-flanges to ANSI 250

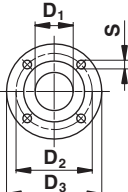

	Nominal flange diameter (NPS)											
	2	2½	3	4	5	6	8	10	12	14	16	
D1	[mm]	50.8	63.5	76.2	102	127	152	203	254	305	337	387
	[inch]	2	2.5	3	4	5	6	8	10	12	13.3	15.3
D2	[mm]	127	149	168	200	235	270	330	387	451	514	572
	[inch]	5	5.88	6.62	7.88	9.25	10.6	13	15.3	17.8	20.3	22.5
D3	[mm]	165	191	210	254	279	318	381	445	521	584	648
	[inch]	6.5	7.5	8.25	10	11	12.5	15	17.5	20.5	23	25.5
S	[mm]	8 x 19.1	8 x 22.4	8 x 22.4	8 x 22.4	8 x 22.4	12 x 22.4	12 x 25.4	16 x 28.5	16 x 31.8	20 x 31.8	20 x 35.1
	[inch]	8 x 0.75	8 x 0.88	8 x 0.88	8 x 0.88	8 x 0.88	12 x 0.88	12 x 1.00	16 x 1.12	16 x 1.25	20 x 1.25	20 x 1.38
Bolt size	5/8"	3/4"	3/4"	3/4"	3/4"	3/4"	7/8"	1"	1 1/8"	1 1/8"	1 1/4"	

Suction diffuser



TM03 3751 0906

Fig. 40 Suction diffuser

General information

A suction diffuser fitted between the suction port and the suction pipe of an HS pump gives the following advantages:

- The suction diffuser provides and ensures a uniform flow pattern to the suction side of the pump. This ensures a stable NPSH.
- The suction diffuser makes it possible to install the HS pump in a very narrow spacing as no long bends are necessary. The suction diffuser may even save floor space - and thus money.
- The suction diffuser incorporates a cylindrical strainer preventing impurities from entering the pump.
- A suction diffuser is easy to dismantle and service. Internal parts such as strainer and guide vane cross can be easily removed, cleaned and/or replaced.

Suction diffuser range

Suction diffusers are available in two versions, SD 12 and SD 22, see technical data below, and a variety of sizes ranging from 80/80 mm to 350/350 mm suction and discharge ports, see dimensional table.

Technical data

	SD 12	SD 22
Pumped liquid	Water	Water
Max. inlet pressure	9.8 bar	19.6 bar
Max. liquid temperature	82 °C	120 °C
Test pressure	14.7 bar	29.4 bar
Materials	Housing and cover	Cast iron / Cast steel
	Strainer	Stainless steel
	Guide vane	Stainless steel
	O-ring	NBR / EPDM

Sectional drawing and components

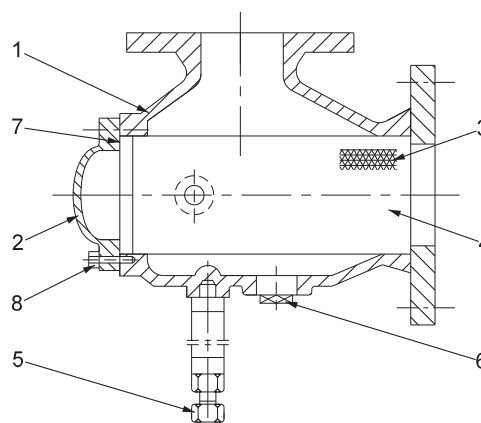

TM03 3748 0906

Fig. 41 Sectional drawing of a suction diffuser

Pos no.	Description	Pos no.	Description
1	Housing	5	Support bolt
2	Cover	6	Drain plug
3	Strainer (inside)	7	O-ring
4	Guide vane (inside)	8	Bolt

Dimensions

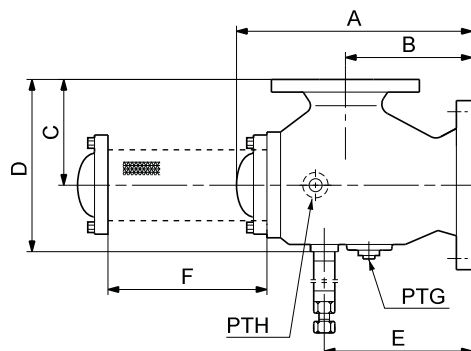

TM03 3749 0906

Fig. 42 Dimensional sketch of suction diffuser

DN size of inlet/outlet	A	B	C	D	E	F	PTG [∅]	PTH [∅]	Weight [kg]
80 x 80	280	140	145	235	180	228	15	15	20
100 x 100	320	165	167	285	195	260	15	15	31
125 x 100	331	175	170	290	210	271	15	15	38
125 x 125	365	191	193	330	230	313	15	15	43
150 x 125	384	209	200	354	250	357	15	15	46
150 x 150	420	220	205	365	260	357	20	15	62
200 x 150	465	240	225	385	300	395	20	15	80
200 x 200	510	264	253	435	335	435	25	15	91
250 x 150	557	285	234	409	335	473	25	15	107
250 x 200	534	271	258	459	350	466	25	15	110
250 x 250	600	310	307	520	380	516	25	15	146
300 x 250	684	350	314	569	430	584	25	15	189
300 x 300	690	367	340	600	410	586	25	15	203
350 x 250	764	380	330	607	460	644	25	15	272
350 x 300	764	379	341	607	460	644	25	15	280
350 x 350	752	370	350	634	460	622	25	15	315

PTG is the diameter of drain role.

PTH is the diameter of a pressure gauge tapping.

Pressure drop

In operation the suction diffuser causes a minor pressure drop.

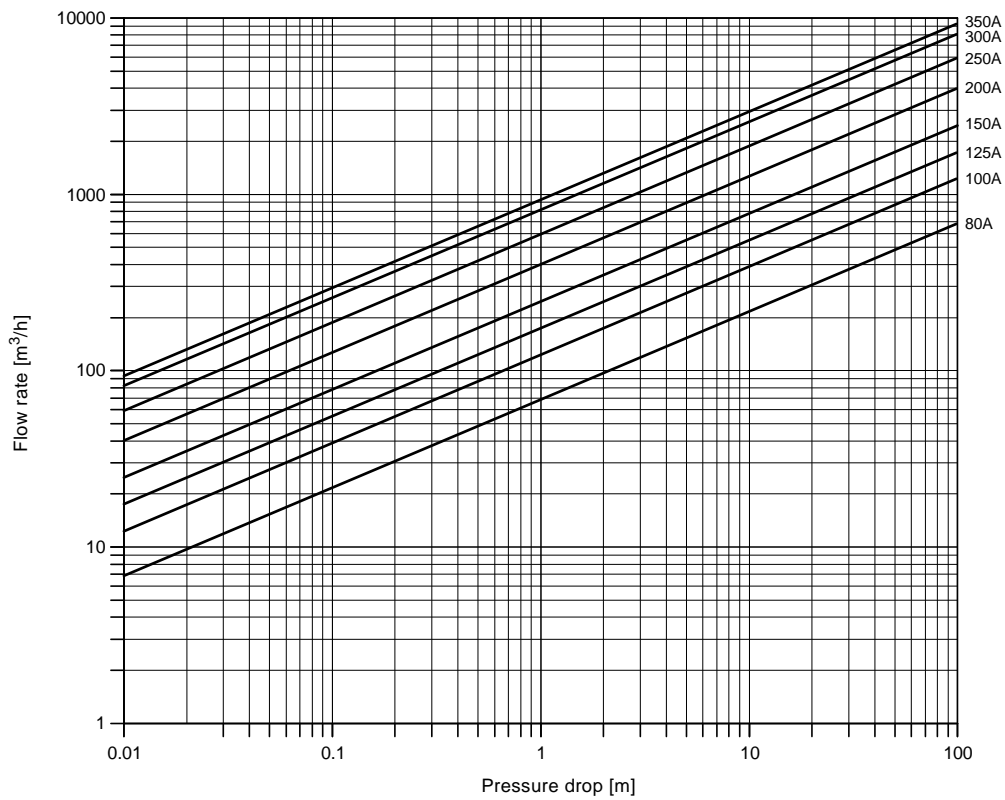

TM03 3894 1106

Fig. 43 Pressure drop graph for suction diffusers.

The designation of the lines, such as "100 A", refers to the DN size of the outlet flange.

Installation

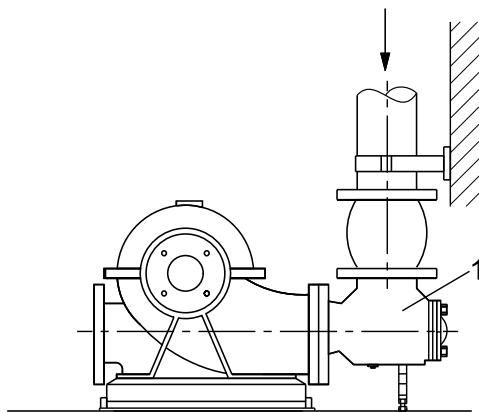

TM04 0096 4907

Fig. 44 Pump installation with suction diffuser (1)

Product numbers

Suction diffusers can be ordered using these product numbers:

DN size of inlet/outlet	Product number	
	SD 12	SD 22
80 x 80	95043154	95043354
100 x 100	95043155	95043355
125 x 100	95043156	95043356
125 x 125	95043157	95043357
150 x 125	95043158	95043358
150 x 150	95043159	95043359
200 x 150	95043160	95043360
200 x 200	95043161	95043361
250 x 150	95043162	95043362
250 x 200	95043163	95043363
250 x 250	95043164	95043364
300 x 250	95043165	95043365
300 x 300	95043166	95043366
350 x 250	95043167	95043367
350 x 300	95043168	95043368
350 x 350	95043169	95043369

Lubricator



Fig. 45 Automatic lubricators; one of them is fitted on a bearing housing.

General information

For the lubrication of motor and pump bearings we recommend the use of automatic lubrication cartridges offering the following advantages:

- constant supply of grease
- permanent and fully automatic lubrication
- high corrosion resistance
- no tools needed for installation
- transparent housing allowing continuous monitoring of the amount of lubricant discharged
- operates in any position
- maintenance-free, recyclable and environmentally friendly
- different lubrication discharge periods; 1, 3 or 6 months.

Mode of operation

Tighten the activating screw in the bottom of the cartridge and a gas generating pellet will drop into a liquid electrolyte starting a chemical reaction. The pressure built-up inside the unit (up to 4 bar) will push against a piston, which in turn will push the lubricant out of the lubricator and into the lubrication point.

The content of lubricant is 100 ml.

Different lubricant discharge periods are indicated by different, colour-coded activating screws in the bottom of the cartridge:

- yellow = 1 month
- green = 3 months
- red = 6 months.

Grease data

Base	Min. oil/Li soap/MoS2
Colour	Grey
Service temperature range	-30 to +120 °C
Drop point, DIN ISO 2176	> 160 °C
Worked penetration, DIN ISO 2137 at 25 °C, 0.1 mm	265 to 295
Consistency, NLGI grade, DIN 51818	2
Density, DIN 51757, at 20 °C, g/cm ³ , approx.	0.87
Flow pressure, DIN 51805, at -30 °C, mbar	< 1400
Water resistance, DIN 51807, 3h/90 °C, rating	0/1-90
Corrosion protection, DIN 51802, Emcor test (1 week, distilled water), corrosion rating	0/1

Note: For all automatic lubricating arrangements it is important to check that the old/replaced grease can run out of the bearing compartment. Otherwise, a pressure will build up over time and the life of the bearing will be reduced.

The components necessary for installing this lubricator on the different HS pumps vary. Therefore it is important to inform the local Grundfos company about the specific size and type.

Product numbers

Lubricators can be ordered using these product numbers:

Lubricator	Product number
Yellow	95043170
Green	95043171
Red	95043172

Pt 100 sensor



Fig. 46 Pt 100 sensor

General information

In some applications it may be advisable to monitor the temperature of the pump bearings. It is possible to fit a Pt 100 temperature sensor on the outside of both pump bearings.

Product number

Pt 100 can be ordered using this product number: 95043173.

WebCAPS

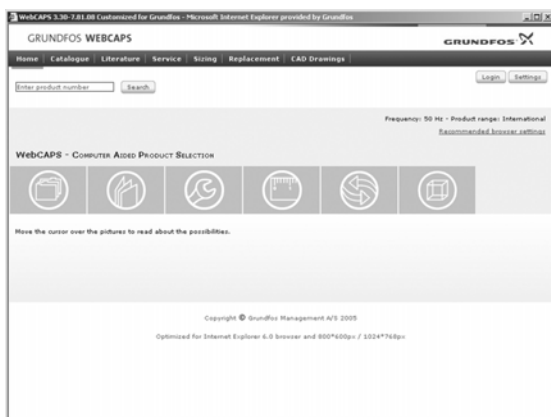

WebCAPS is a **Web**-based **Computer Aided Product Selection** program available on www.grundfos.com.

WebCAPS contains detailed information on more than 185,000 Grundfos products in more than 20 languages.

In WebCAPS, all information is divided into 6 sections:

- Catalogue
- Literature
- Service
- Sizing
- Replacement
- CAD drawings.

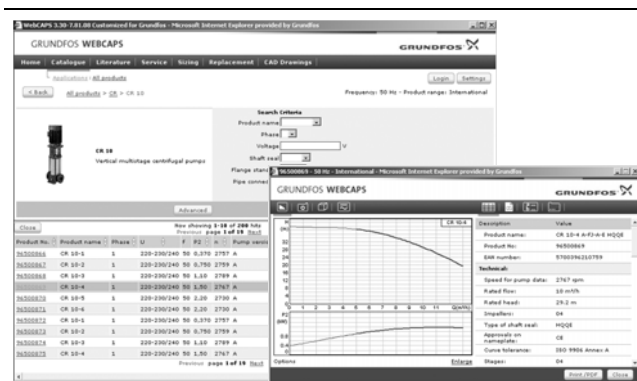

Catalogue

With a starting point in areas of applications and pump types, this section contains

- technical data
- curves (QH, Eta, P1, P2, etc) which can be adapted to the density and viscosity of the pumped liquid and show the number of pumps in operation
- product photos
- dimensional drawings
- wiring diagrams
- quotation texts, etc.

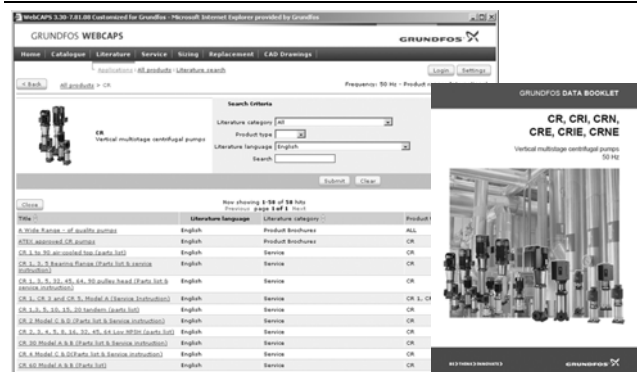

Literature

In this section you can access all the latest documents of a given pump, such as

- data booklets
- Installation and operating instructions
- service documentation, such as Service kit catalogue and Service kit instructions
- quick guides
- product brochures, etc.

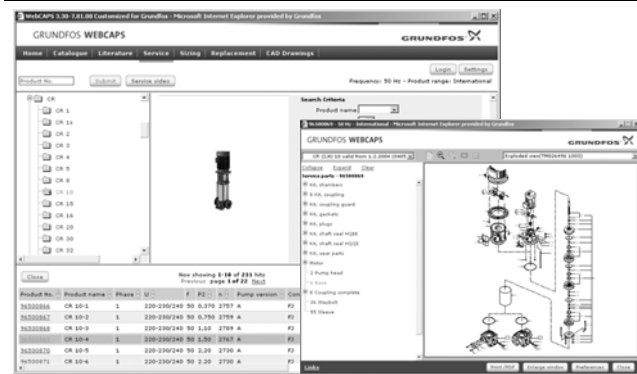

Service

This section contains an easy-to-use interactive service catalogue. Here you can find and identify service parts of both existing and cancelled Grundfos pumps.

Furthermore, this section contains service videos showing you how to replace service parts.



Sizing

With a starting point in different application areas and installation examples, this section gives easy step-by-step instructions in how to

- select the most suitable and efficient pump for your installation
- carry out advanced calculations based on energy consumption, payback periods, load profiles, lifecycle costs, etc.
- analyse your selected pump via the built-in lifecycle cost tool
- determine the flow velocity in wastewater applications, etc.



Replacement

In this section you find a guide to select and compare replacement data of an installed pump in order to replace the pump with a more efficient Grundfos pump. The section contains replacement data of a wide range of pumps produced by other manufacturers than Grundfos.

Based on an easy step-by-step guide, you can compare Grundfos pumps with the one you have installed on your site. After having specified the installed pump, the guide suggests a number of Grundfos pumps which can improve both comfort and efficiency.

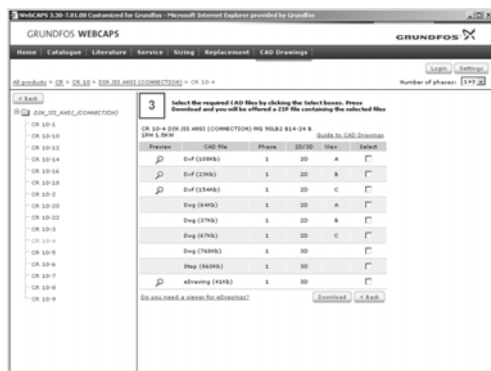

CAD drawings

In this section it is possible to download 2-dimensional (2D) and 3-dimensional (3D) CAD drawings of most Grundfos pumps.

The following formats are available in WebCAPS:

2-dimensional drawings

- .dxf, wireframe drawings
- .dwg, wireframe drawings.

3-dimensional drawings

- .dwg, wireframe drawings (without surfaces)
- .stp, solid drawings (with surfaces)
- .eprt, E-drawings.

WinCAPS



Fig. 47 WinCAPS CD-ROM

WinCAPS is a **Windows-based Computer Aided Product Selection** program containing detailed information on more than 185,000 Grundfos products in more than 20 languages.

The program contains the same features and functions as WebCAPS, but is an ideal solution if no Internet connection is available.

WinCAPS is available on CD-ROM and updated once a year.

96827075 0509	GB
Repl. 96827075 0708	

Subject to alterations.