



CATALOGUE OF PUMPING EQUIPMENT

WATER SUPPLY
SEWAGE DISPOSAL

ENGINEERING FLOW SOLUTIONS





HMS GROUP

dynamically developing diversified holding having a powerful research and production complex in the field of design and production of pumping and skid mounted modular equipment for various industries: oil and gas industry, power industry, pipeline transport, water industry, and housing and utilities.

An important line of the Group activity is also turnkey construction of projects and integrated arrangement of facilities for oil and gas production, water supply, and water removal.

Major lines of activity

design and production of pumping equipment:

- pumps for oil and gas industry;
- pumps for thermal and nuclear power industry;
- pumps for water industry and housing and utilities, utility pumps;
- pumps for pipeline transport;
- pumps for metallurgy, minerals industry etc.

design and production of oil and gas equipment:

- block and modular equipment for integrated arrangement of oil and gas deposits;
- equipment and instruments for measuring the flow of oil, gas, and water;
- repair and service maintenance of oil and gas equipment.

engineering in the field of surface arrangement of facilities of oil and gas sector and water industry:

- design and construction of facilities for surface arrangement of oil and gas deposits;
- design and construction of facilities for water supply and water removal;
- construction of main pipelines and infield oil and gas pipelines.

HMS GROUP includes the leading pumping and oil equipment manufacturers, engineering and service companies

INDUSTRIAL PUMPS

HMS PUMPS JSC, Livny, Russia

Manufacturing of pumps for various applications

LIVNYNASOS JSC, Livny, Russia

Manufacturing of submersible centrifugal pumps for water industry

NASOENERGOMASH JSC, Sumy, Ukraine

Manufacturing of pumps for oil and gas industries, thermal and nuclear power plants, household and public utilities, and water industry

HYDROMASHSERVICE JSC, Moscow, Russia

Consolidated trade company of HMS GROUP

VNIIAEN JSC, Sumy, Ukraine

Research and development of pumps for nuclear and energy industries

PROMBURVOD JSC, Minsk, Belarus

Manufacturing of submersible centrifugal pumps for water industry

DIMITROVGRADKHIIMMASH JSC, Dimitrovgrad, Russia

Manufacturing of vessels, chemical equipment and pumps

HMS HOUSEHOLD PUMPS JSC, Bavleny, Vladimir region, Russia

Manufacturing and marketing of household pumps

OIL & GAS EQUIPMENT

HMS NEFTEMASH JSC, Tyumen, Russia

Modular (packaged) oil field equipment manufacturer

SIBNEFTEAVTOMATIKA JSC, Tyumen, Russia

Design and manufacturing of flow metering equipment

NIZHNEVARTOVSKREMSERVICE JSC, Nizhnevartovsk, Russia

Repair, upgrade and maintenance of oil field equipment

ENGINEERING

GIPROTYUMENNEFTEGAZ JSC, Tyumen, Russia

Engineering of integrated oil and gas fields developments

TOMSKGAZSTROY JSC, Tomsk, Russia

Construction of oil & gas industries facilities

TREST SIBKOMPLEKTMONTAZHNALADKA JSC, Tyumen, Russia

Construction of oil and gas industry facilities

INSTITUTE ROSTOVSKY VODOKANALPROEKT JSC, Rostov-on-Don, Russia

Design of water supply systems, water drainage systems and hydraulic structures

TABLE OF CONTENTS

PUMPING EQUIPMENT FOR WATER INDUSTRY AND HOUSING AND PUBLIC UTILITIES

Centrifugal double suction pumps of D type and electric pump units on their basis.....	3
Diesel pump units of DNA type.....	35
Submersible electric pump units of 2ECV type with leak proof motors of DAP series.....	39
Centrifugal submersible electric pump units of ECV type	42
Electric motor control and protection unit – SUIZ «LOTSMAN+»	63
Electric motor control and protection unit – SUZ	65
Electric motor control and protection unit – SUZ «RODNIK»	67
Electric motor control and protection unit – SUZ «SIGNAL»	69
Centrifugal multistage pumps of CNSg type and electric pump units on their basis	71
Centrifugal multistage sectional pumps of CNSv type and electric pump units on their basis	87
Centrifugal end-suction pumps of 1K type and electric pump units on their basis.....	91
Centrifugal end-suction pumps of K 45/30 type and electric pump units on their basis.....	102
Centrifugal end-suction pumps of 1K 8/18 and 1K 20/30 type and electric pump units on their basis.....	105
Centrifugal end-suction pumps of 2K type and electric pump units on their basis	110
Centrifugal end-suction closed-coupled electric pumps of 1KM type.....	114
Centrifugal end-suction closed-coupled electric pumps of linear 1KML type	119
Vortex pumps of VK, VKS, VKO type and electric pump units on their basis.....	122
Centrifugal vortex pumps of CVK type	131
Centrifugal cantilever pumps of SM type and electric pump units on their basis	135
Vortex pumps of SMS type and electric pump units on their basis	142
Centrifugal closed-coupled submersible electric pumps of CMF type	146
Centrifugal submersible electric pumps of GNOM type.....	150
Single-screw pumps of N1V type.....	156
Water-circuit vacuum pumps of VVN type	161
Automated pumping water booster systems - AUPD	166

DOMESTIC PUMPS

Domestic vibration electric pumps MALYSH, RUCHEEK	174
Single-screw self-priming electric pumps of series BURUN®	177
Single-screw self-priming submersible electric pumps of series BURUN® PF	183
Domestic centrifugal submersible electric pump of BCP type.....	185
Table of pump usage.....	187
Table of pump descriptions in various periods	188
Questionnaire form for ordering pumping equipment	

CENTRIFUGAL DOUBLE SUCTION PUMPS OF D TYPE AND ELECTRIC PUMP UNITS ON THEIR BASIS

APPLICATION

Centrifugal double-suction pumps of **D** type and electric pump units on their basis are intended for pumping of water and other liquids with the viscosity properties and chemical activity similar to water-up to $36 \times 10^{-6} \text{ m}^2/\text{s}$ (36cSt), temperature from 1 to 85 °C, with the dry solids content not more than 0.05% by weight, with the size not more than 0.2 mm, and micro-hardness not more than 6.5 hPa (650 kgf/mm²).

The pumps (units) are manufactured in climatic version UHL (moderate cold), T location category 3.1, 2 under GOST 15150-69.

The pumps (units) are not intended for use in explosion and fire hazardous premises.

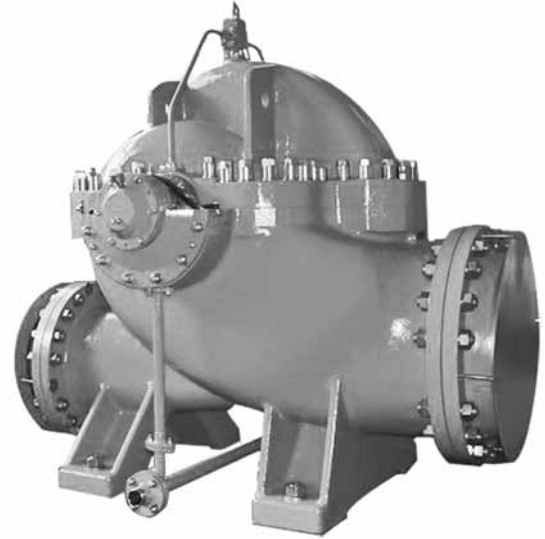

PERFORMANCE RANGE

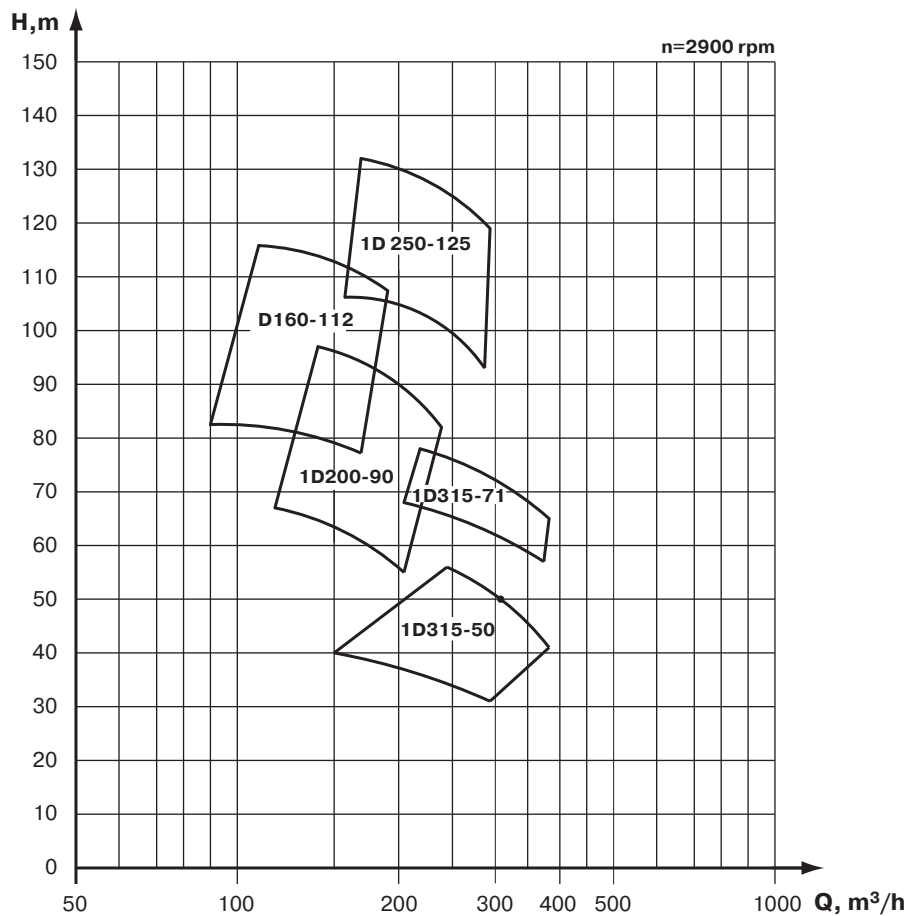

PERFORMANCE RANGE

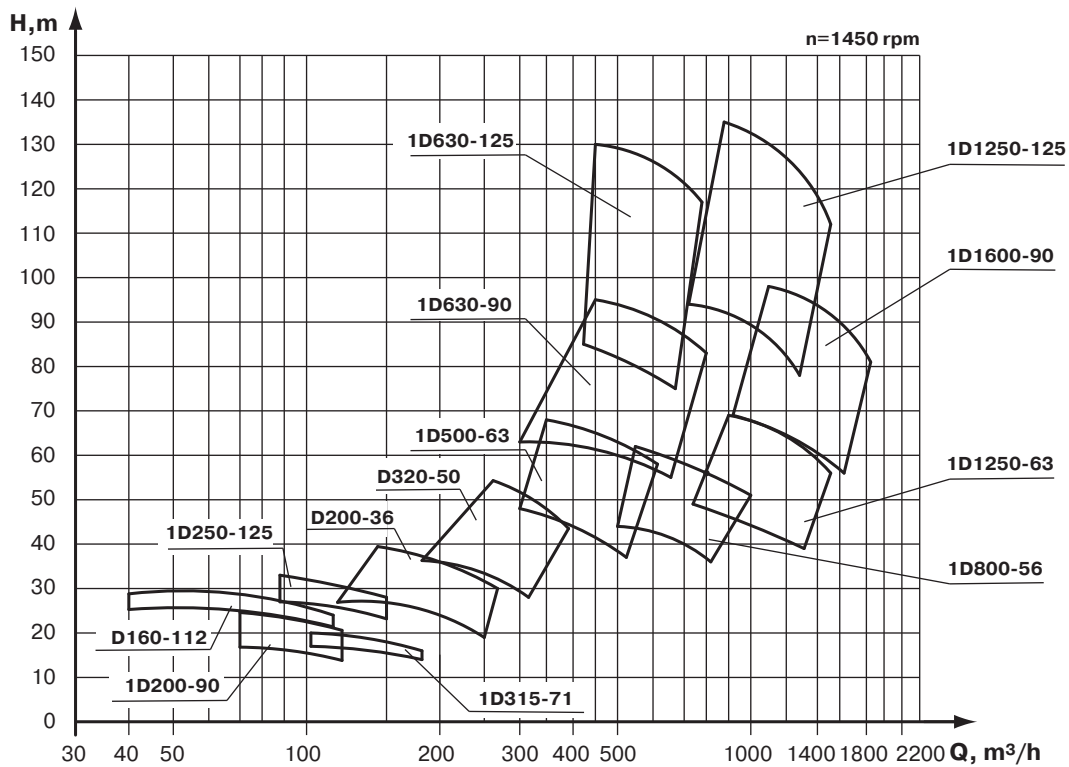
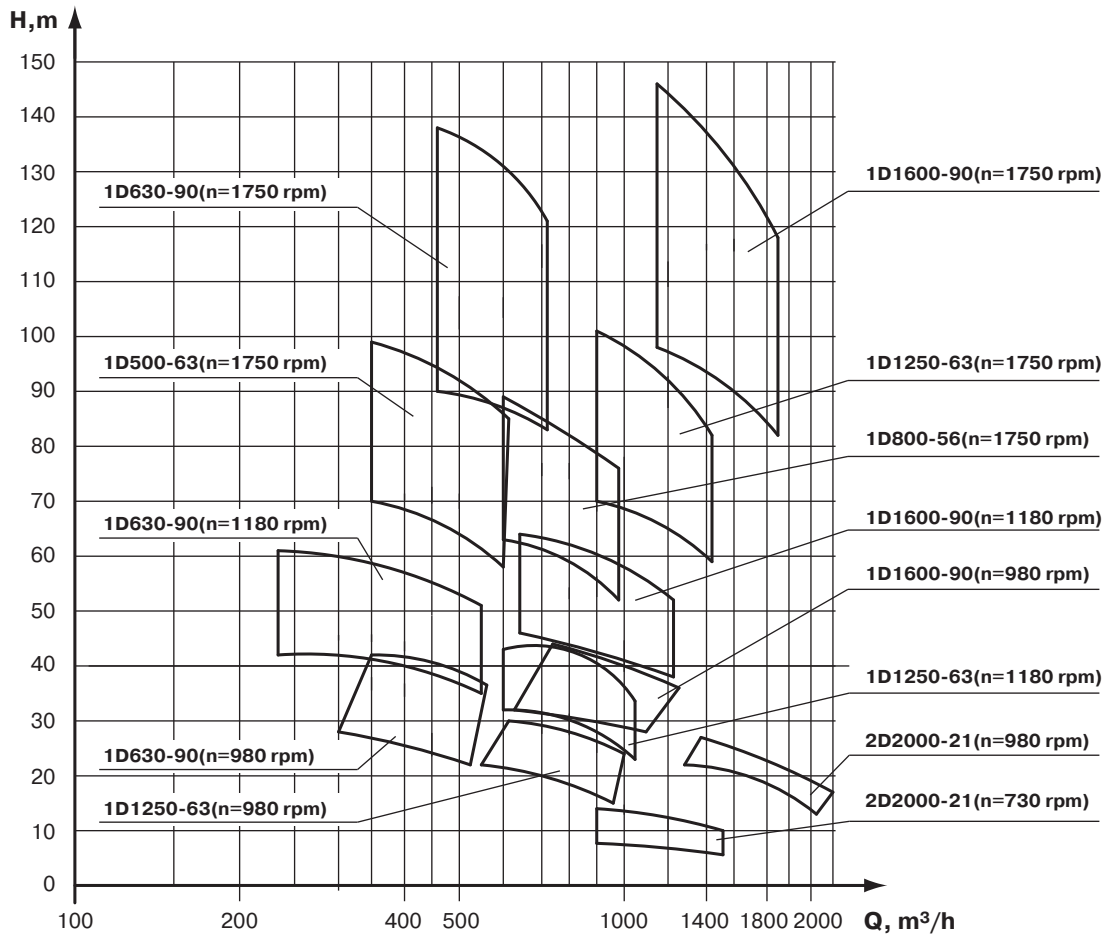

PERFORMANCE RANGE

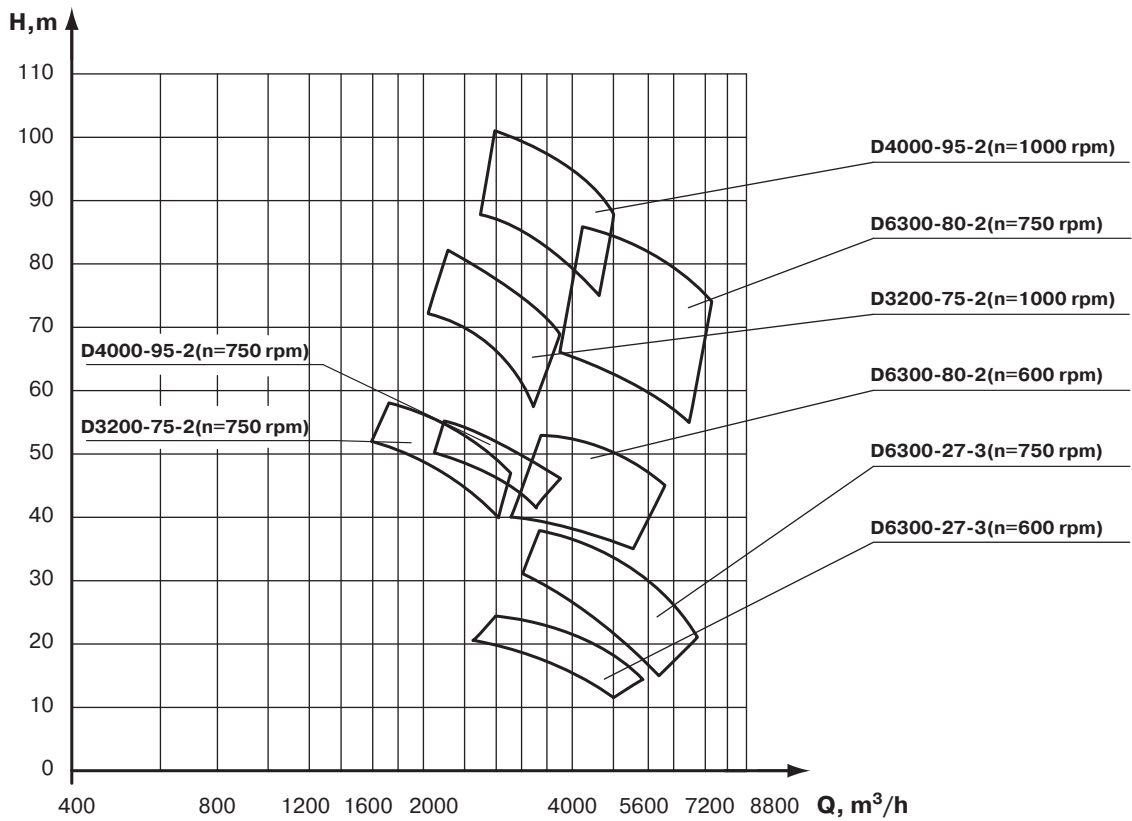
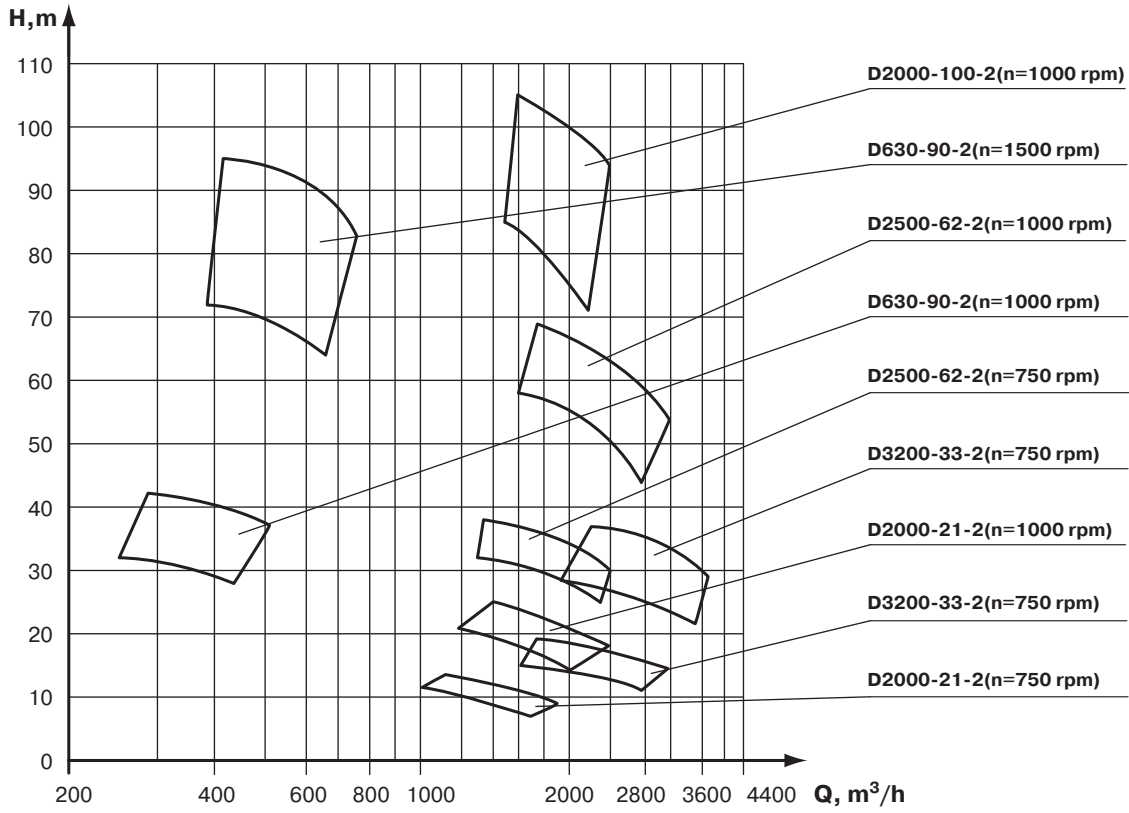

PUMP TYPE KEY

Example of designation:

1D200-90 UHL3.1 / D2500-62a-St-2 UHL4 E

X D XXXX - XX x - Xx - X UHLX X

upgrade serial number
under the manufacturer system*

double suction

capacity, m³/h

head, m

impeller turn designation
(not specified in basic version)

designation of version according to the material
of impeller and packing ring in case of export version
(not specified in basic version)

upgrade serial number
under the manufacturer system*

designation of climatic version and location category
in case of pump export supply

export version identification index

* pump upgrade numbers vary in locations in designation depending on the manufacturers

TECHNICAL PARAMETERS

pump (unit) model	capacity, m ³ /h, (m ³ /s)	head, m	rotation speed, s ⁻¹ (rpm)	pump power input, kW	net positive suction head, m	pump efficiency, %, min.	pump weight, kg
D160-112m	160 (0.044)	122	48.3 (2900)	78	4.8	73	200
D160-112	160 (0.044)	112		70		73	
D160-112a	150 (0.041)	100		58		71	
D160-112b	135 (0.037)	80		45		67	
D160-112m	90 (0.025)	29,5	24.2 (1450)	12	4.5	72	240
D160-112	80 (0.022)	28		10		72	
D160-112a	70 (0.019)	25		8		71	
D200-36	200 (0.055)	36		25		4.3	
D200-36a	190 (0.053)	29,7	24.2 (1450)	20.5	5.3	73	240
D200-36b	180 (0.049)	25		16	6.0	68	
D320-50	320 (0.088)	50		52	4.5	80	
D320-50a	300 (0.083)	39	48.3 (2900)	41	4.6	77	300
D320-50b	300 (0.083)	30		32	4.8	73	
1D200-90	200 (0.055)	90		65	5.5	77	
1D200-90a	180 (0.049)	74	24.2 (1450)	50	5.8	74	145
1D200-90b	160 (0.044)	62		37	5.9	69	
1D200-90	100 (0.028)	22,5		8.5	5.3	76	
1D250-125	250 (0.069)	125	48.3 (2900)	110	6.0	76	165
1D250-125a	240 (0.066)	101		85	6.4	73	
1D250-125b	225 (0.063)	90		75	6.6	70	
1D250-125	125 (0.035)	30		24.2 (1450)	24	5.5	

TECHNICAL PARAMETERS								
pump (unit) model	capacity, m ³ /h, (m ³ /s)	head, m	rotation speed, s ⁻¹ (rpm)	pump power input, kW	net positive suction head, m	pump efficiency, %, min.	pump weight, kg	
1D315-50	315 (0.087)	50	48.3 (2900)	53	6.5	83	190	
1D315-50a	300 (0.083)	42		42	6.7	79		
1D315-50b	230 (0.061)	36		28	6.8	74		
1D315-71	315 (0.087)	71		78	6.5	83		
1D315-71a	300 (0.083)	62		63	7	79		
1D315-71b	280 (0.078)	52		55	7.3	76		
1D315-71	150 (0.041)	18	24.2 (1450)	14.5	6.5	83	450	
1D500-63	500 (0.140)	63		107	4.5	80		
1D500-63a	450 (0.125)	53		80	4.8	77		
1D500-63b	400 (0.111)	44		65	5	75		
1D630-90	630 (0.175)	90		188	5.5	82		524
1D630-90a	550 (0.153)	74		142	5.8	78		
1D630-90b	500 (0.140)	60	102	5.9	78			
1D630-90	500 (0.140)	38	74	5	80			
1D630-90a	470 (0.131)	30	59	5.1	77			
1D630-90b	420 (0.117)	25	42	5.2	72			
1D630-125	630 (0.175)	125	24.2 (1450)	290	5.5	75	797	
1D630-125a	550 (0.153)	101		210	5.6	72		
1D630-125b	500 (0.14)	82		160	5.7	70		
1D800-56	800 (0.220)	56		145	5	84		560
1D800-56a	740 (0.205)	48		119	5.1	81		
1D800-56b	700 (0.195)	40		100	5.2	76		
1D1250-63	800 (0.220)	28	16.3 (980)	82	5.5	87	800	
1D1250-63a	740 (0.205)	24		64	5.6	84		
1D1250-63b	710 (0.197)	20		47	5.7	79		
1D1250-63	1250 (0.350)	63	24.2 (1450)	246	6	87		1300
1D1250-63a	1100 (0.306)	52,5		187	6.1	84		
1D1250-63b	1050 (0.292)	44		149	6.2	79		
1D1250-125	1250 (0.350)	125		519	5.5	82		
1D1250-125a	1150 (0.319)	102		404	5.6	80		
1D1250-125b	1030 (0.286)	87		317	5.7	75		
1D1600-90	1000 (0.280)	40	16.3 (980)	140	5	85	1165	
1D1600-90a	970 (0.269)	34		104	5.1	82		
1D1600-90b	870 (0.242)	30		84	5.2	77		
1D1600-90	1600 (0.445)	90	24.2 (1450)	460	7.0	85		1165
1D1600-90a	1450 (0.403)	75		360	7.1	82		
1D1600-90b	1300 (0.361)	63		275	7.2	77		
2D2000-21	1250 (0.347)	13	12.2 (730)	56	3	88	1565	
2D2000-21a	1250 (0.347)	10		42	3.5	85		
2D2000-21	2000 (0.556)	21	16.3 (980)	135	5	86		1565
2D2000-21a	1750 (0.486)	18		99	5	84		

TECHNICAL PARAMETERS							
pump (unit) model	capacity, m ³ /h, (m ³ /s)	head, m	rotation speed, s ⁻¹ (rpm)	pump power input, kW	net positive suction head, m	pump efficiency, %, min.	pump weight, kg
D2000-100-2	2000 (0.55)	100	16.3 (980)	665	6.0	82	2470
D2000-100a-2	1900 (0.53)	88	16.3 (980)	577	6.0	79	2470
D2000-100b-2	1800 (0.5)	80	16.3 (980)	510	6.0	77	2460
D2500-62-2	2500 (0.7)	62	16.3 (980)	480	6	88.5	2700
	2000 (0.55)	34	12.2 (730)	210	4	88.5	
D2500-62a-2	2300 (0.64)	52	16.3 (980)	380	6	86.5	2690
	1900 (0.53)	29	12.2 (730)	175	4	86.5	
D3200-33-2	3200 (0.9)	33	16.3 (980)	320	6.5	90	2700
	2500 (0.7)	17	12.2 (730)	130	4.0	90	
D3200-33a-2	3000 (0.83)	29	16.3 (980)	270	6.5	88	2700
	2400 (0.67)	15	12.2 (730)	110	4.0	88	
D3200-33b-2	2800 (0.78)	25	16.3 (980)	220	6.5	86	2700
	2300 (0.64)	13	12.2 (730)	95	4.0	86	
D3200-75-2	3200 (0.9)	75	16.3 (980)	740	6.5	88.5	3650
	2500 (0.7)	42	12.2 (730)	325	4	88.5	
D3200-75a-2	3000 (0.83)	65	16.3 (980)	615	6.5	86.5	3640
	2300 (0.64)	35	12.2 (730)	255	4	86.5	
D4000-95-2	4000 (0.11)	95	16.3 (980)	1170	7.0	88.5	4660
	3200 (0.9)	50	12.2 (730)	495	5.0		4650
D4000-95a-2	3700 (0.103)	82	16.3 (980)	955	7.0	86.5	4650
	3000 (0.83)	45	12.2 (730)	425	5.0		
D6300-27-3	6300 (0.175)	27	12.2 (730)	515	7.5	90	4600
	5000 (0.14)	17	9.9 (585)	260	5.0	90	
D6300-27-3-1	5000 (0.14)	32	12.2 (730)	485	7.5	90	4600
	4000 (0.11)	20	9.9 (585)	240	5.0	90	
D6300-27a-3	5800 (0.161)	24	12.2 (730)	430	7.5	88	4600
	4620 (0.128)	15	9.9 (585)	215	5.0	88	
D6300-27b-3	5450 (0.151)	22	12.2 (730)	380	7.5	88	4600
	4350 (0.118)	14	9.9 (585)	195	5.0	88	
D6300-80-2	6300 (0.175)	80	12.2 (730)	1550	6.5	88.5	8170
	5000 (0.14)	50	9.9 (585)	770	5.5	88.5	
D6300-80a-2	5900 (0.164)	70	12.2 (730)	1300	6.5	86.5	8160
	4700 (0.131)	45	9.9 (585)	665	5.5	86.5	
D6300-80b-2	5500 (0.153)	60	12.2 (730)	1060	6.5	84.5	8150
	4000 (0.122)	38	9.9 (585)	540	5.5	84.5	
D12500-10	12500	10	6.2 (372)	426	6.0	82.5	14830
D12500-24	12500	24	8.25 (495)	929	7.0	89	14830

PERFORMANCE CURVE

D160-112 * – pump data
rotation speed 24.2 s^{-1} (1450 rpm)
liquid – water ($20 \text{ }^\circ\text{C}$), density 1000 kg/m^3

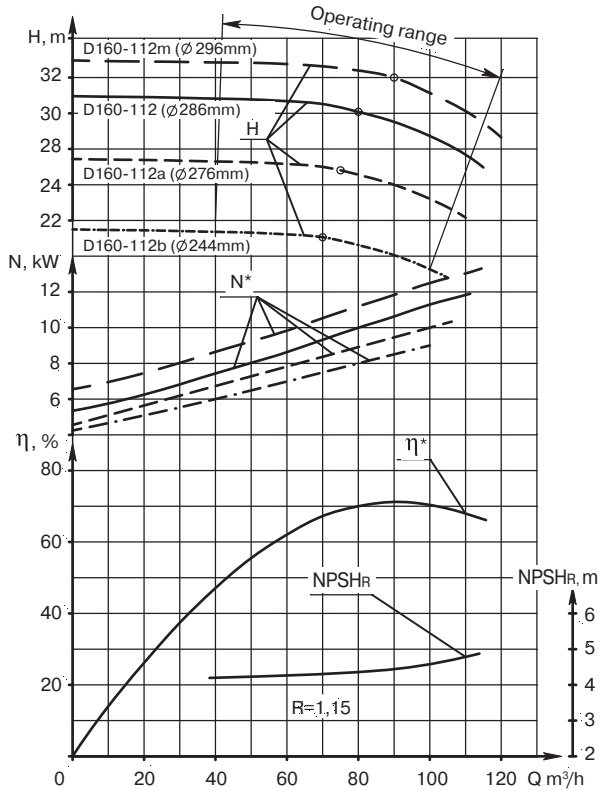

D160-112 * – pump data
rotation speed 48.3 s^{-1} (2900 rpm)
liquid – water ($20 \text{ }^\circ\text{C}$), density 1000 kg/m^3

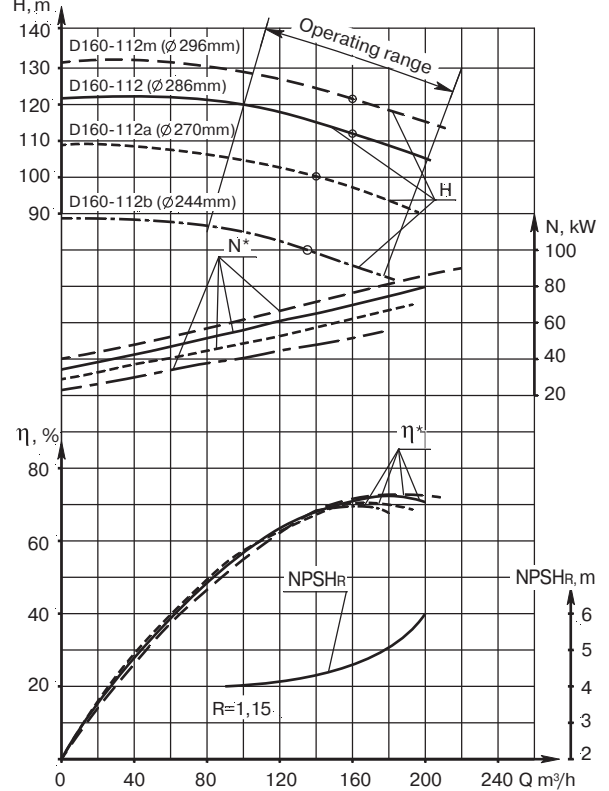

D200-36 * – pump data
rotation speed 24.2 s^{-1} (1450 rpm)
liquid – water ($20 \text{ }^\circ\text{C}$), density 1000 kg/m^3

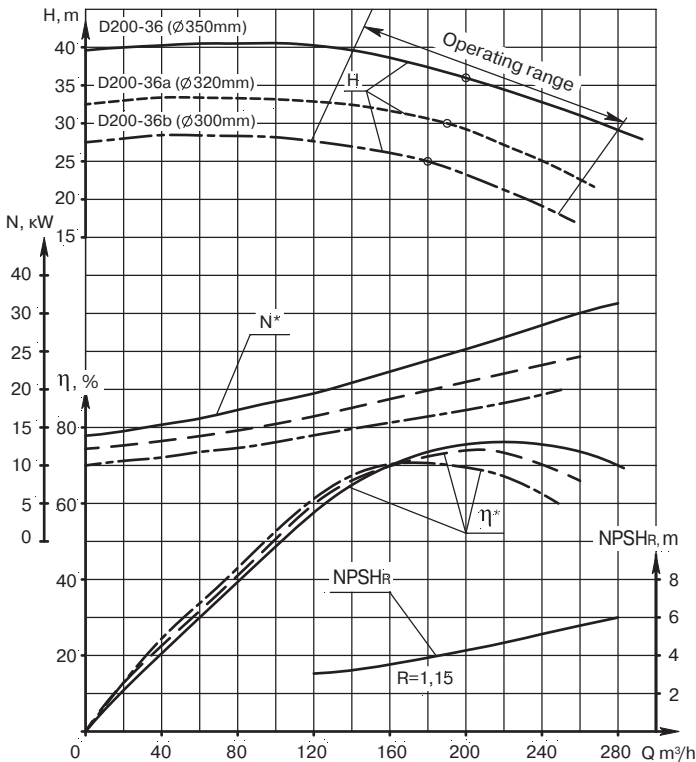

D320-50 * – pump data
rotation speed 24.2 s^{-1} (1450 rpm)
liquid – water ($20 \text{ }^\circ\text{C}$), density 1000 kg/m^3

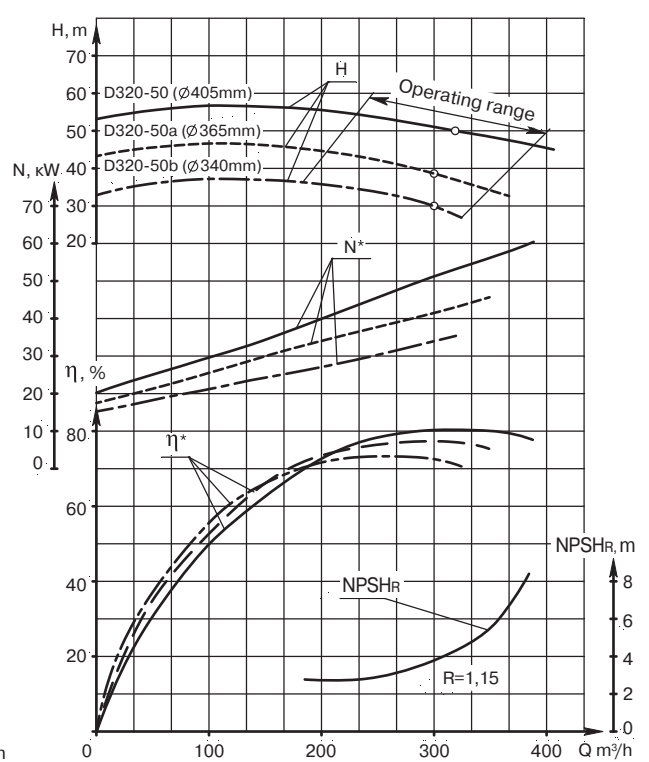

PERFORMANCE CURVE

1D200-90 * – pump data
rotation speed 24.2 s^{-1} (1450 rpm)
liquid – water (20 °C), density 1000 kg/m^3

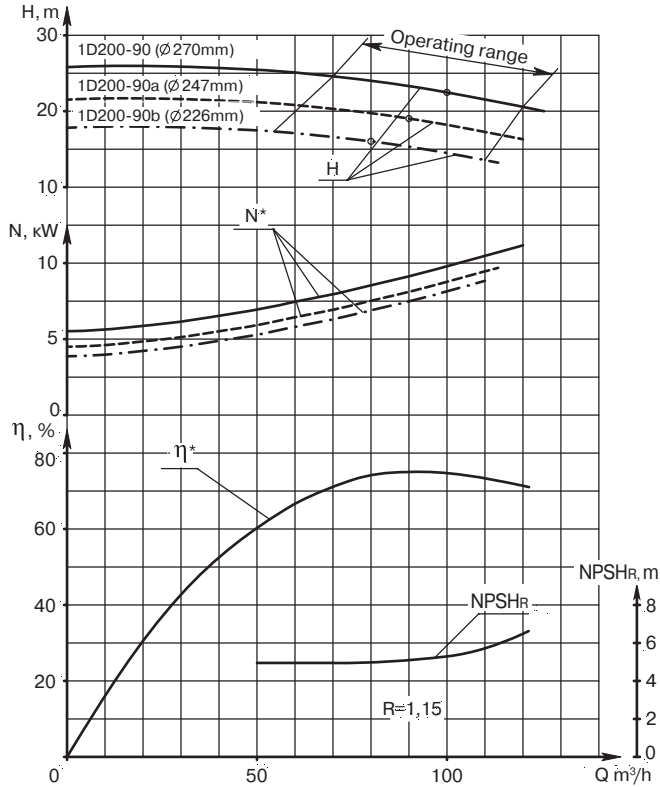

1D200-90 * – pump data
rotation speed 48.3 s^{-1} (2900 rpm)
liquid – water (20 °C), density 1000 kg/m^3

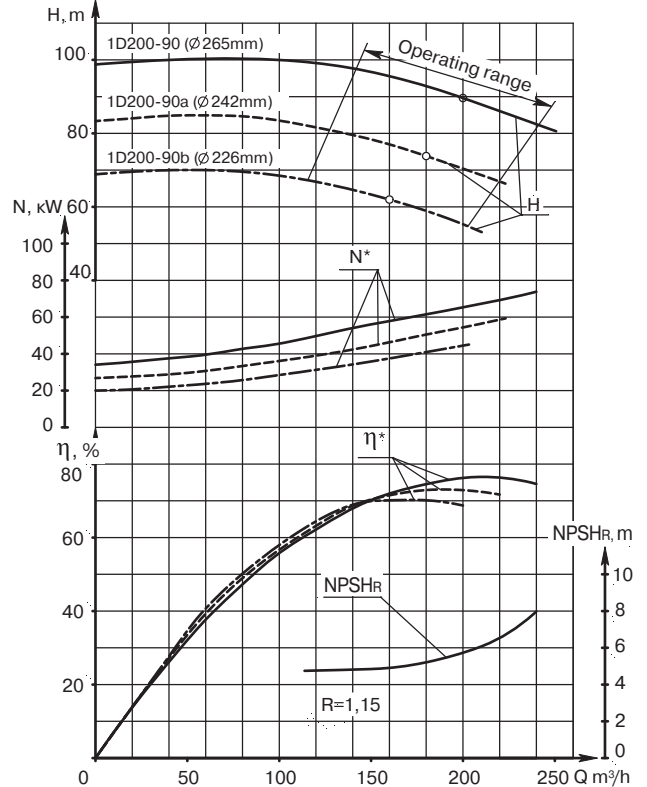

1D250-125 * – pump data
rotation speed 24.2 s^{-1} (1450 rpm)
liquid – water (20 °C), density 1000 kg/m^3

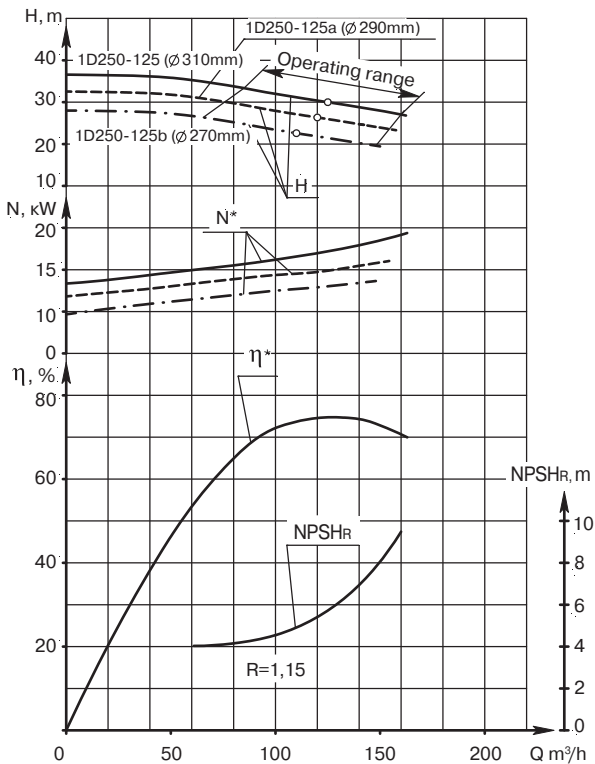

1D250-125 * – pump data
rotation speed 48.3 s^{-1} (2900 rpm)
liquid – water (20 °C), density 1000 kg/m^3

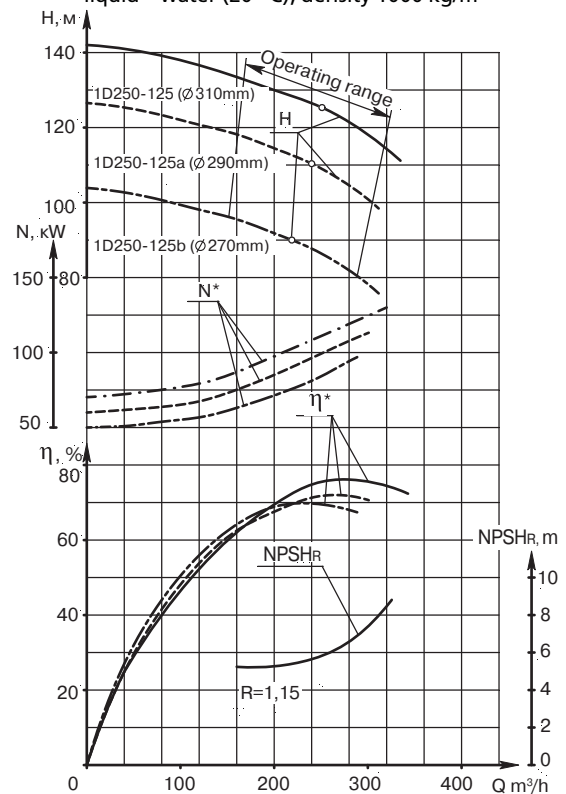

PERFORMANCE CURVE

1D315-71 * – pump data
rotation speed 24.2 s^{-1} (1450 rpm)
liquid – water (20 °C), density 1000 kg/m^3

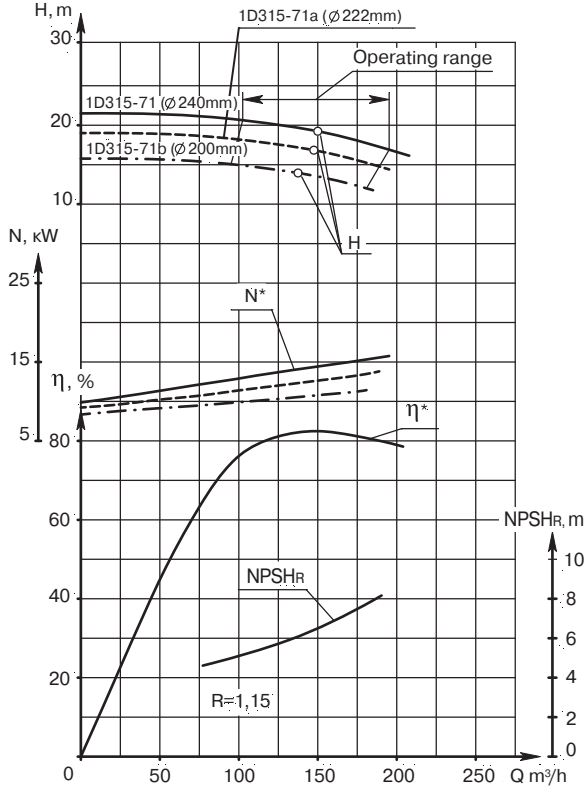

1D315-71 * – pump data
rotation speed 48.3 s^{-1} (2900 rpm)
liquid – water (20 °C), density 1000 kg/m^3

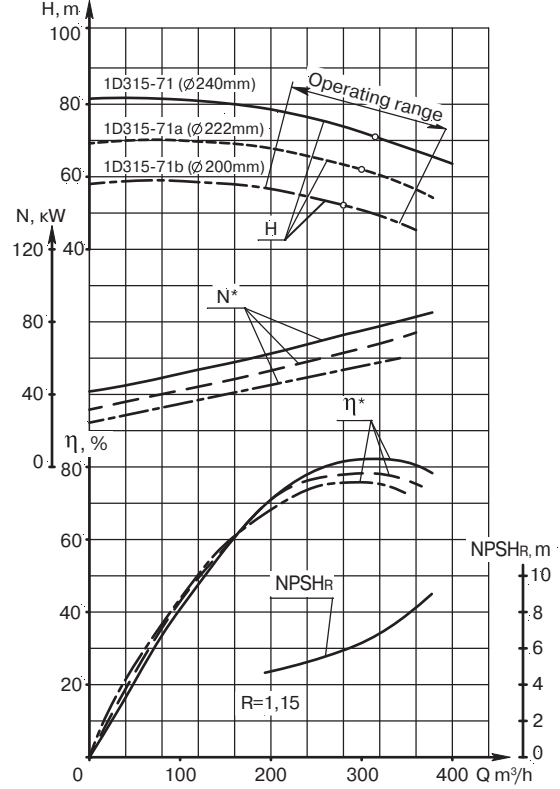

1D315-50 * – pump data
rotation speed 48.3 s^{-1} (2900 rpm)
liquid – water (20 °C), density 1000 kg/m^3

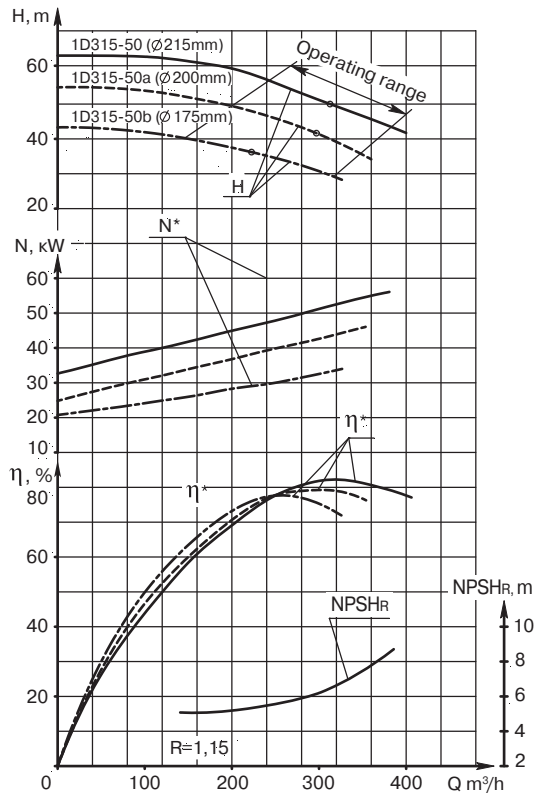

1D500-63 * – pump data
rotation speed 24.2 s^{-1} (1450 rpm)
liquid – water (20 °C), density 1000 kg/m^3

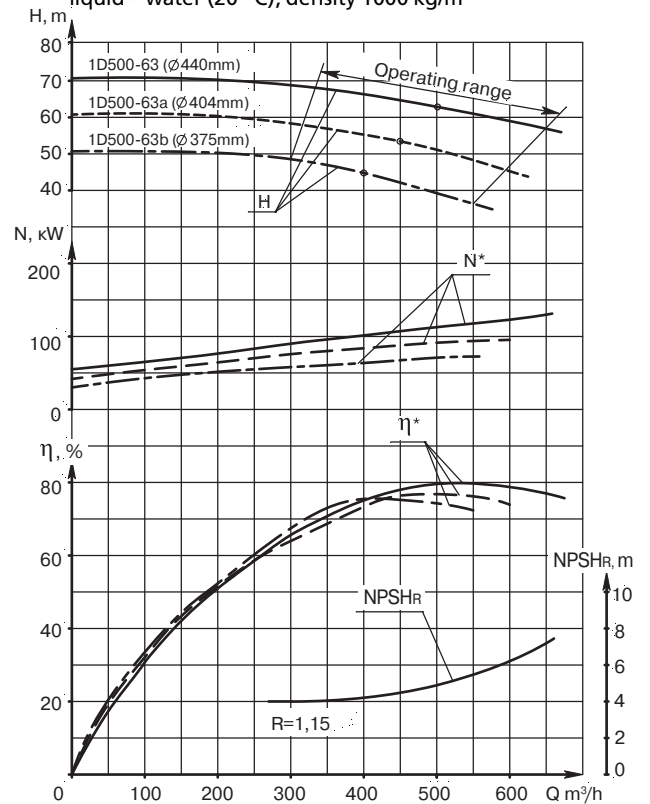

PERFORMANCE CURVE

1D630-90 * – pump data
rotation speed 16.3 s^{-1} (980 rpm)
liquid – water (20 °C), density 1000 kg/m^3

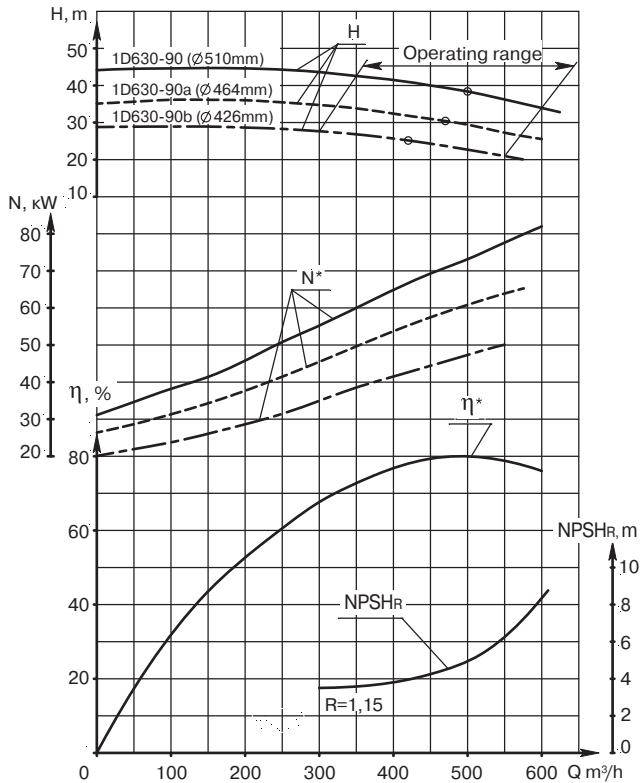

1D630-90 * – pump data
rotation speed 24.2 s^{-1} (1450 rpm)
liquid – water (20 °C), density 1000 kg/m^3

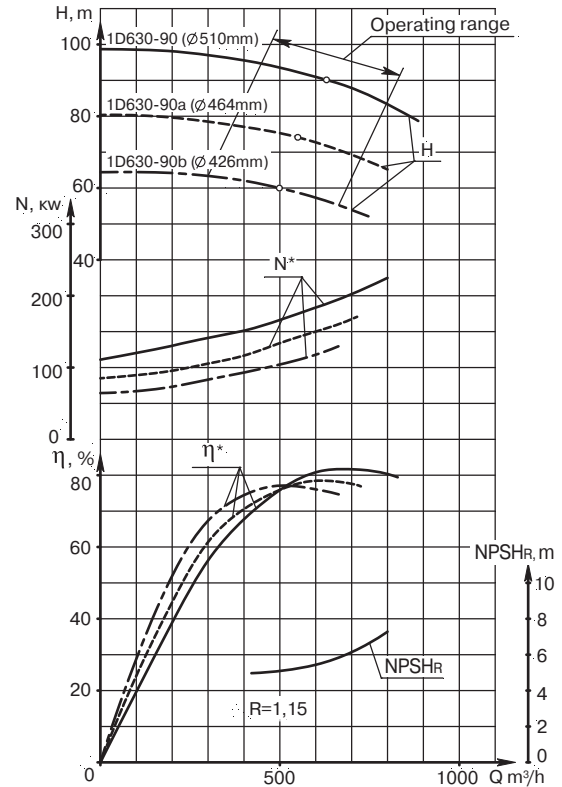

1D630-125 * – pump data
rotation speed 24.2 s^{-1} (1450 rpm)
liquid – water (20 °C), density 1000 kg/m^3

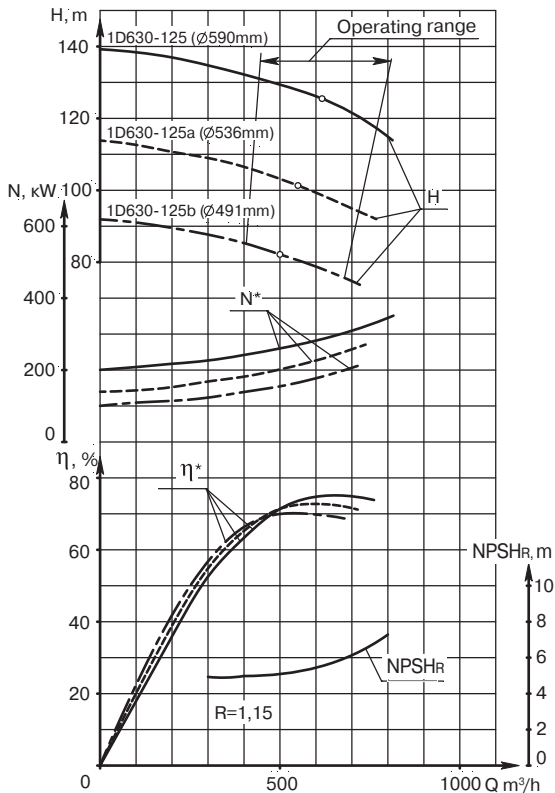

1D800-56 * – pump data
rotation speed 24.2 s^{-1} (1450 rpm)
liquid – water (20 °C), density 1000 kg/m^3

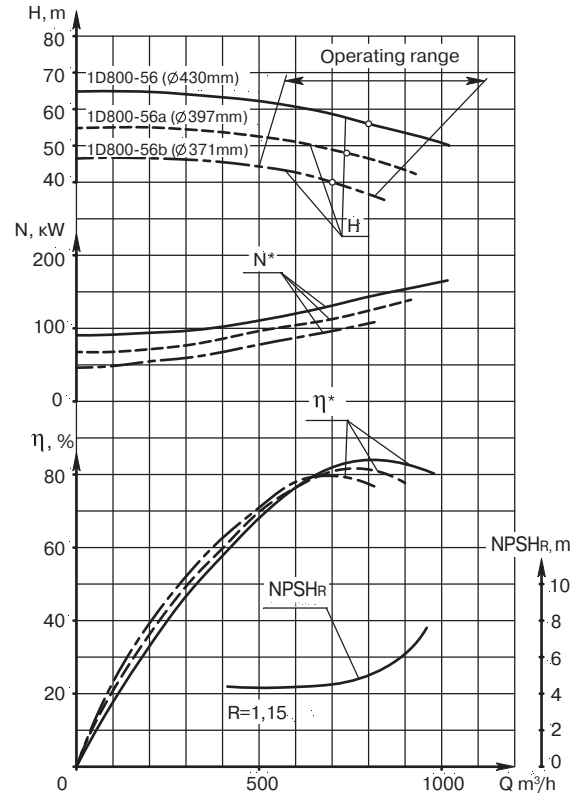

PERFORMANCE CURVE

1D1250-63 * – pump data
rotation speed 16.3 s^{-1} (980 rpm)
liquid – water (20 °C), density 1000 kg/m^3

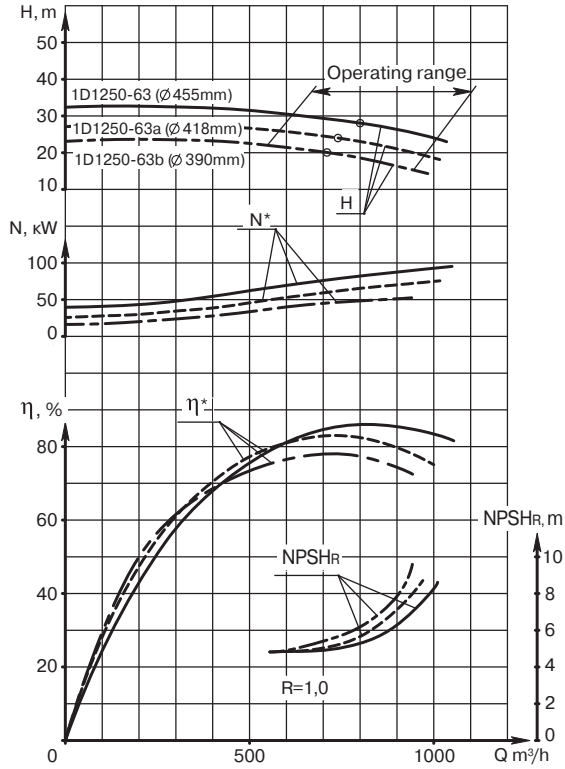

1D1250-63 * – pump data
rotation speed 24.2 s^{-1} (1450 rpm)
liquid – water (20 °C), density 1000 kg/m^3

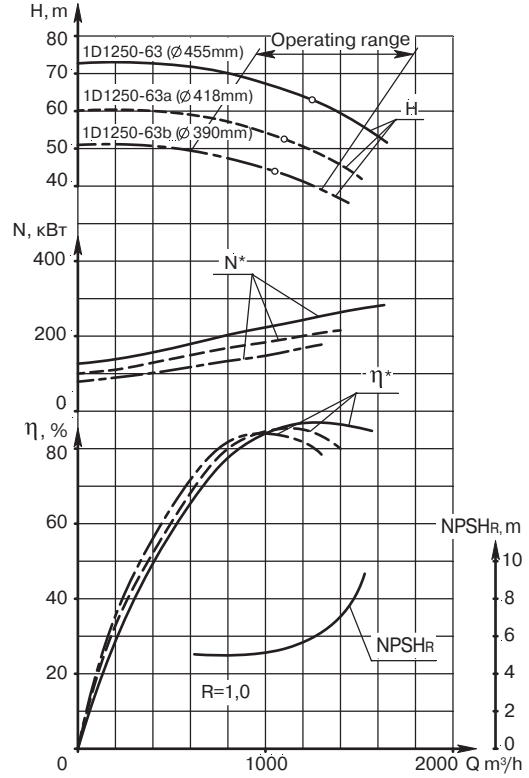

1D1250-125 * – pump data
rotation speed 24.2 s^{-1} (1450 rpm)
liquid – water (20 °C), density 1000 kg/m^3

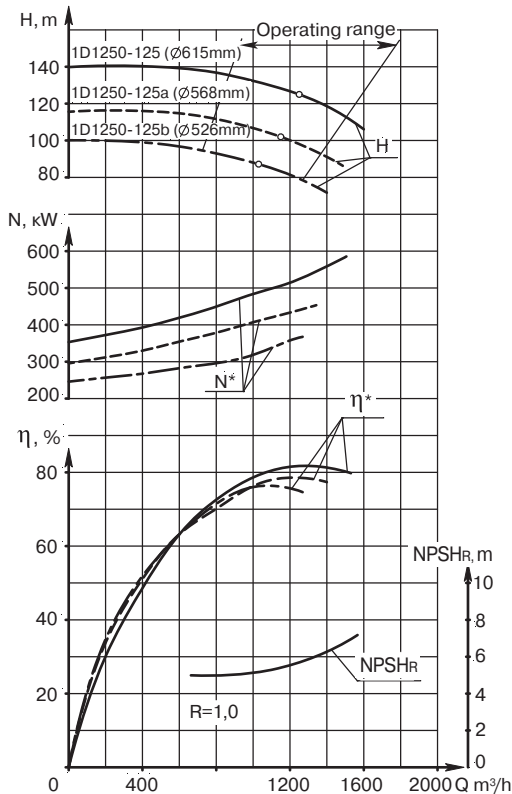

1D1600-90 * – pump data
rotation speed 16.3 s^{-1} (980 rpm)
liquid – water (20 °C), density 1000 kg/m^3

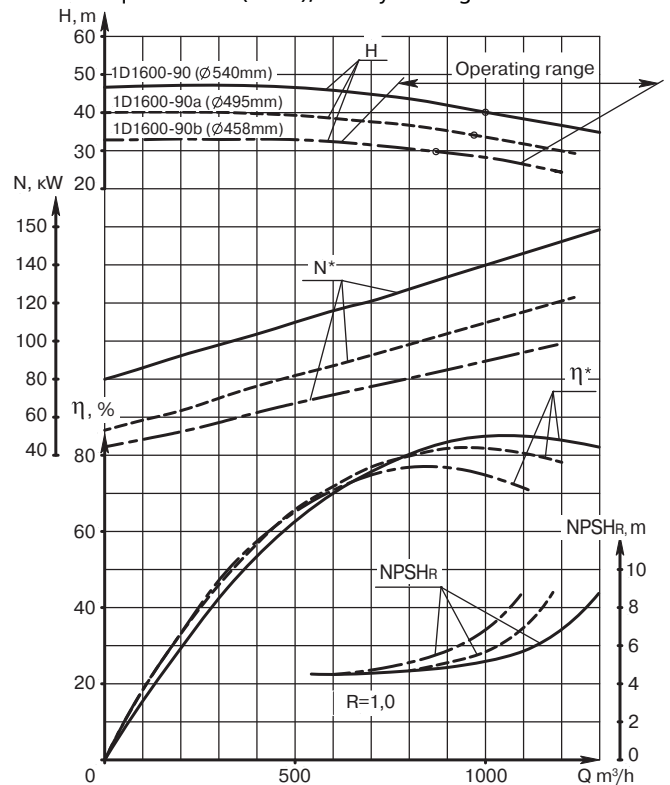

PERFORMANCE CURVE

1D1600-90 * – pump data
rotation speed 24.2 s^{-1} (1450 rpm)
liquid – water (20 °C), density 1000 kg/m^3

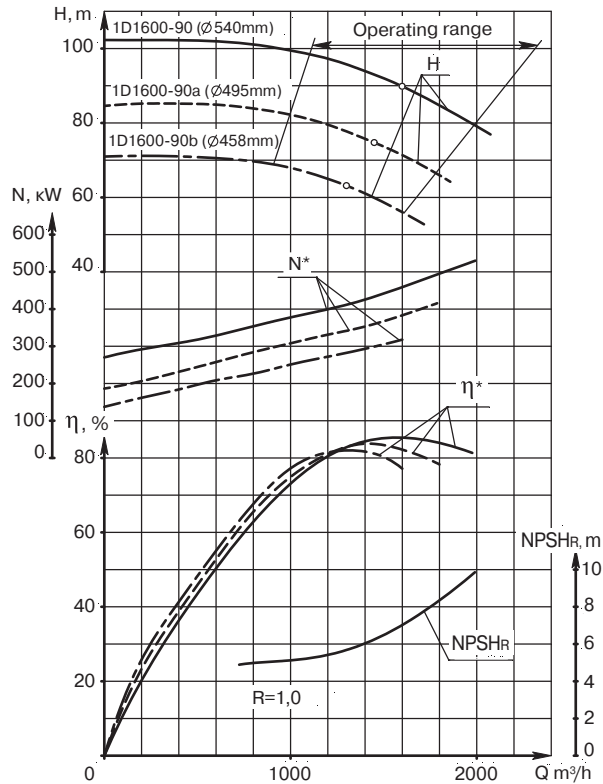

2D2000-21 * – pump data
rotation speed 12.2 s^{-1} (730 rpm)
liquid – water (20 °C), density 1000 kg/m^3

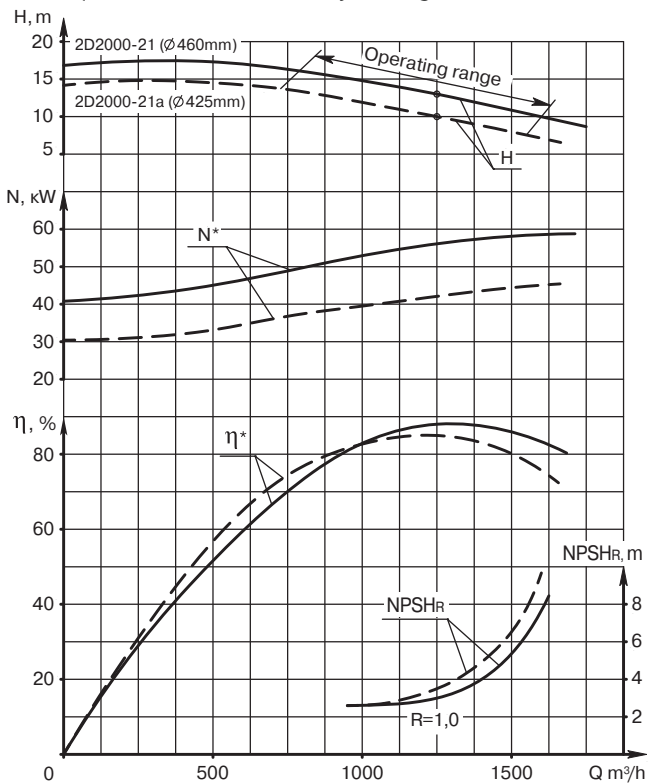

2D2000-21 * – pump data
rotation speed 16.3 s^{-1} (980 rpm)
liquid – water (20 °C), density 1000 kg/m^3

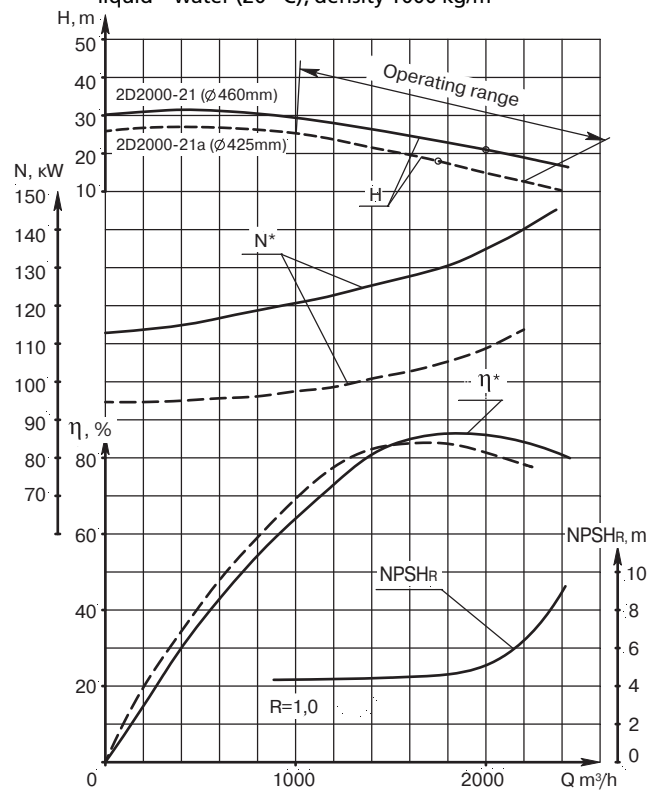

PERFORMANCE CURVE

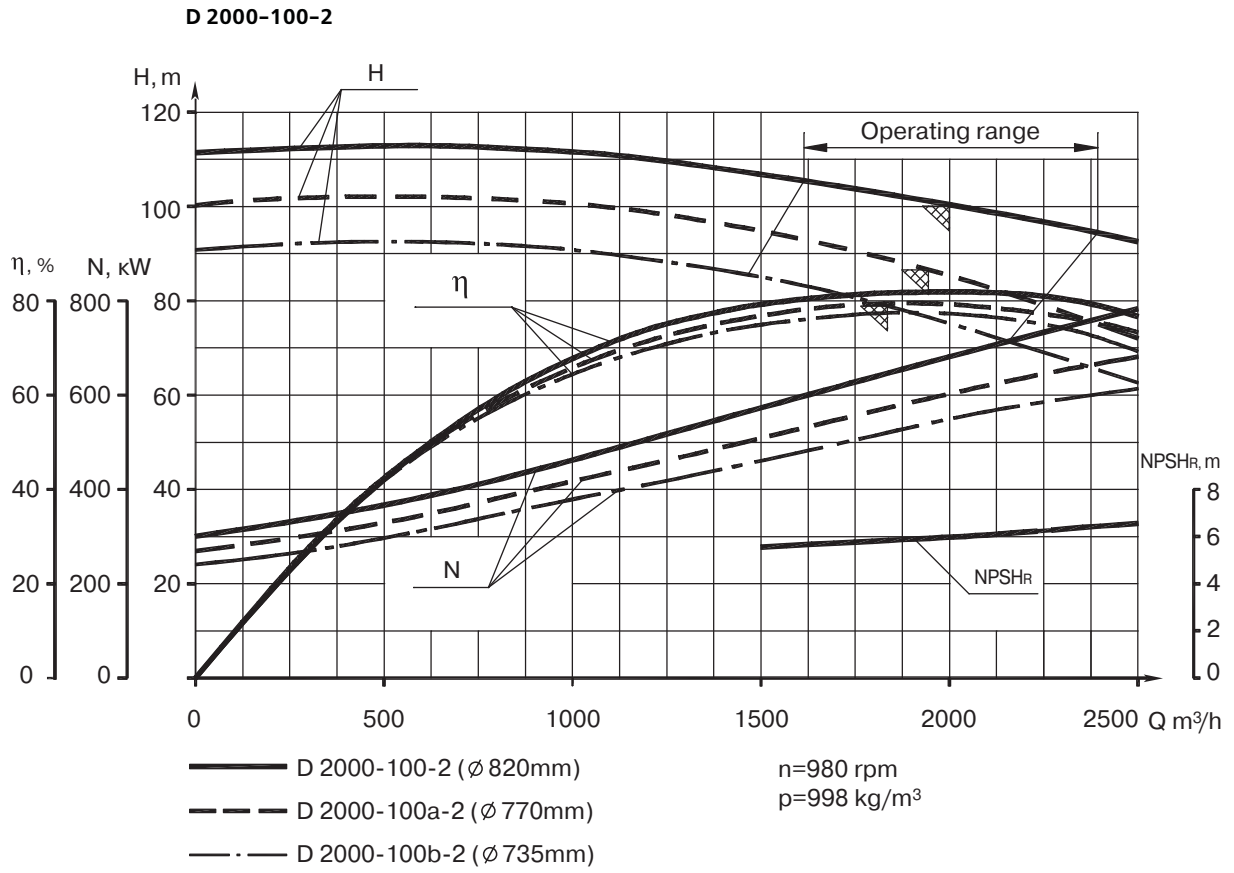

PERFORMANCE CURVE

D 2500-62-2

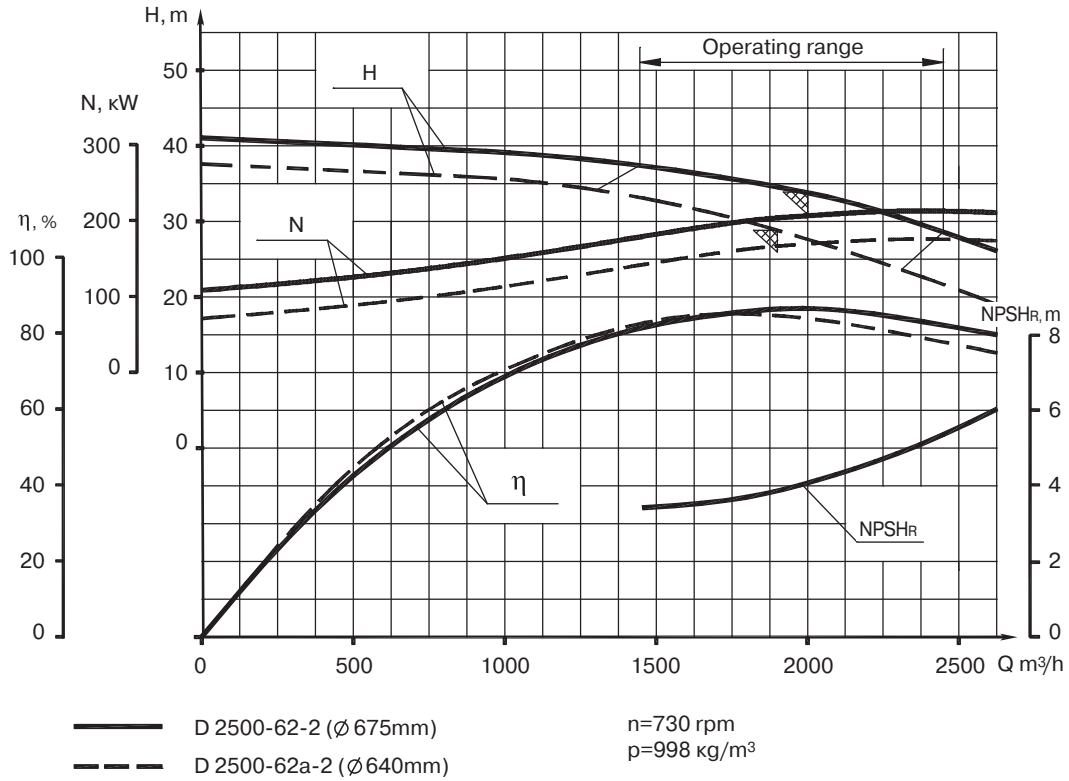

D 2500-62-2

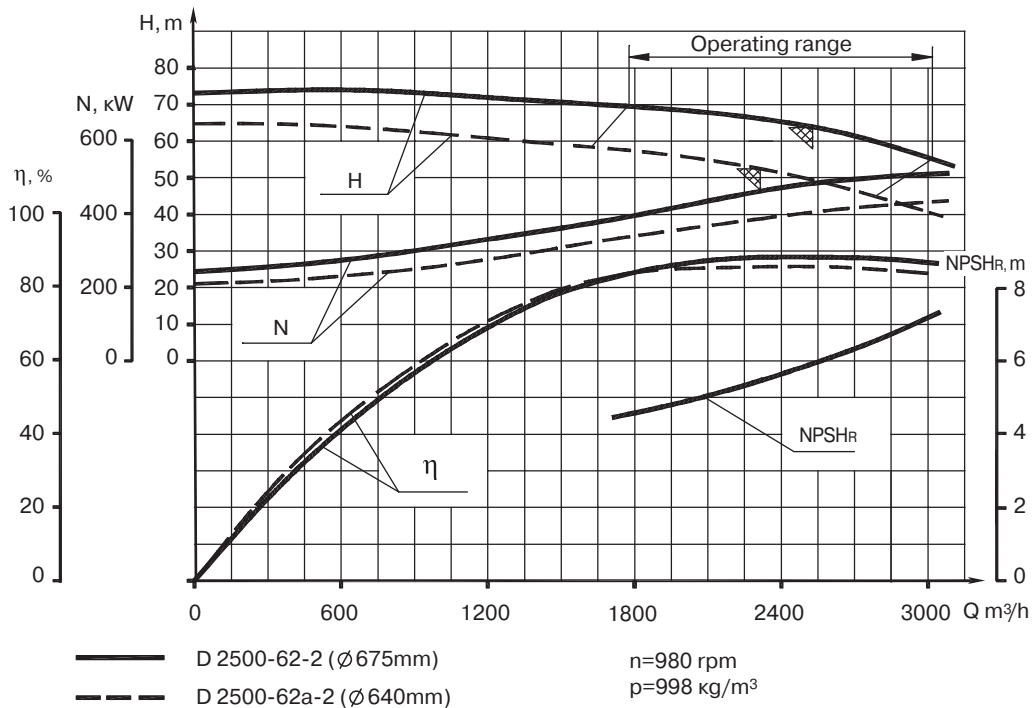

PERFORMANCE CURVE

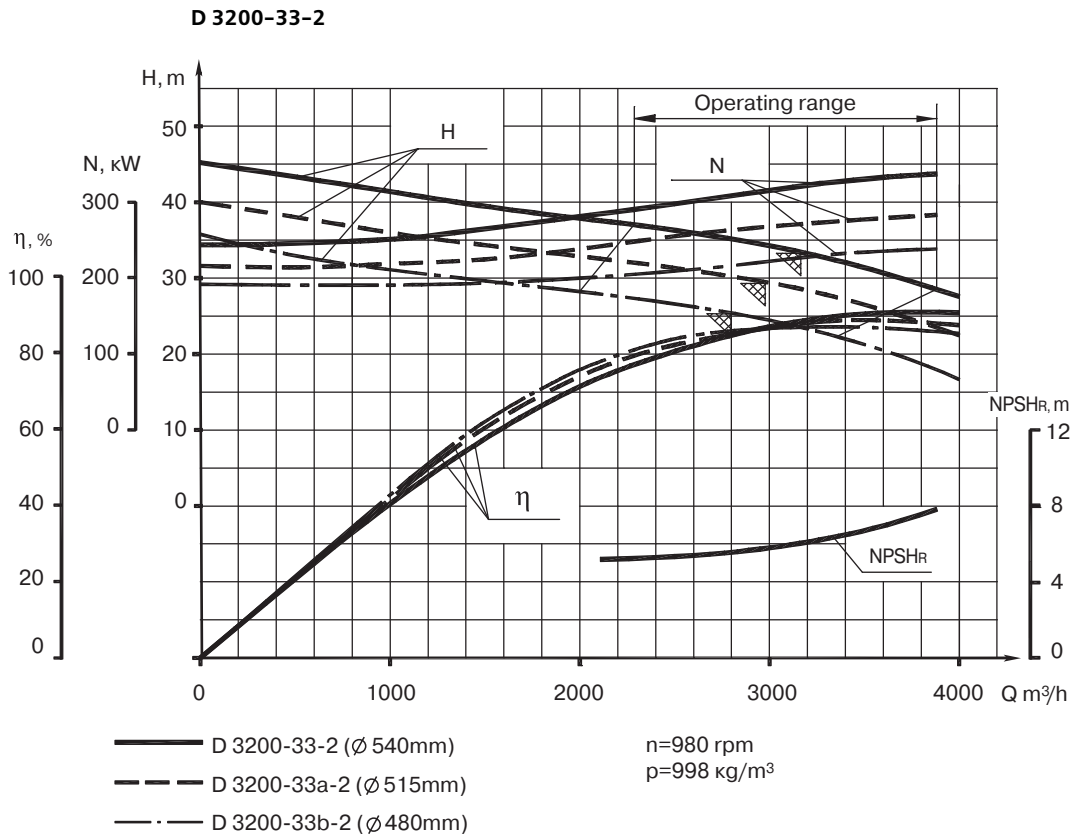
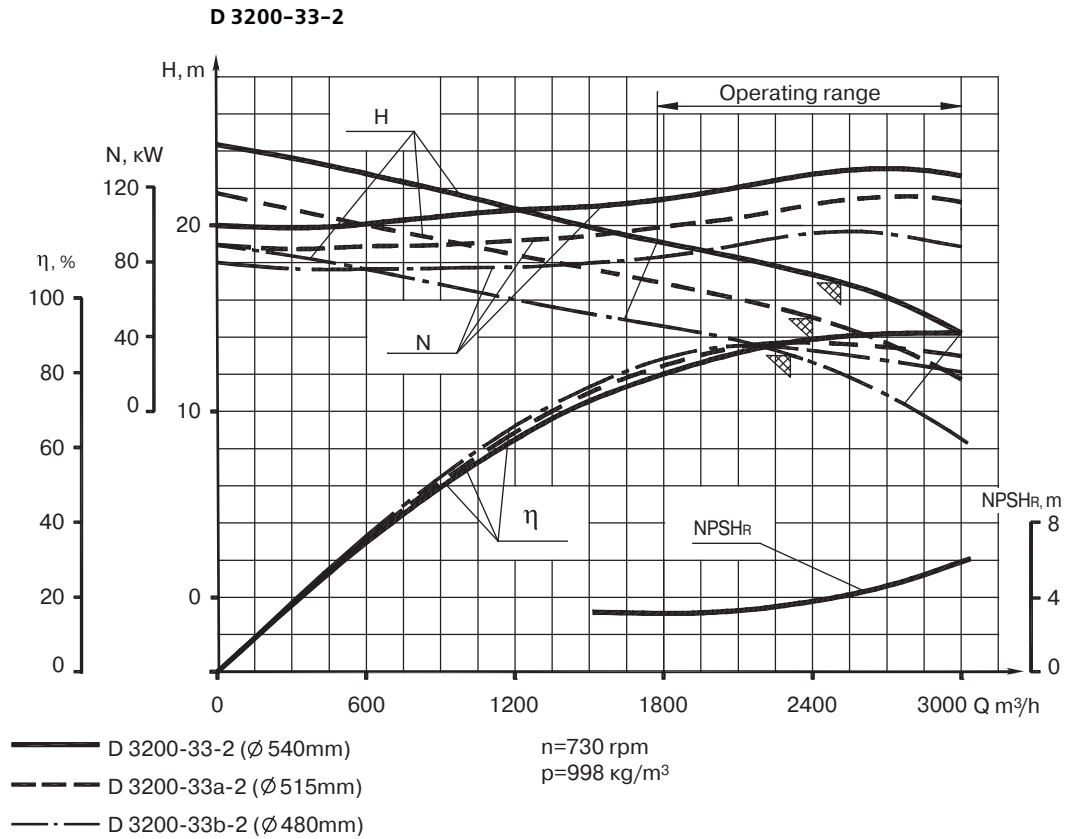

PERFORMANCE CURVE

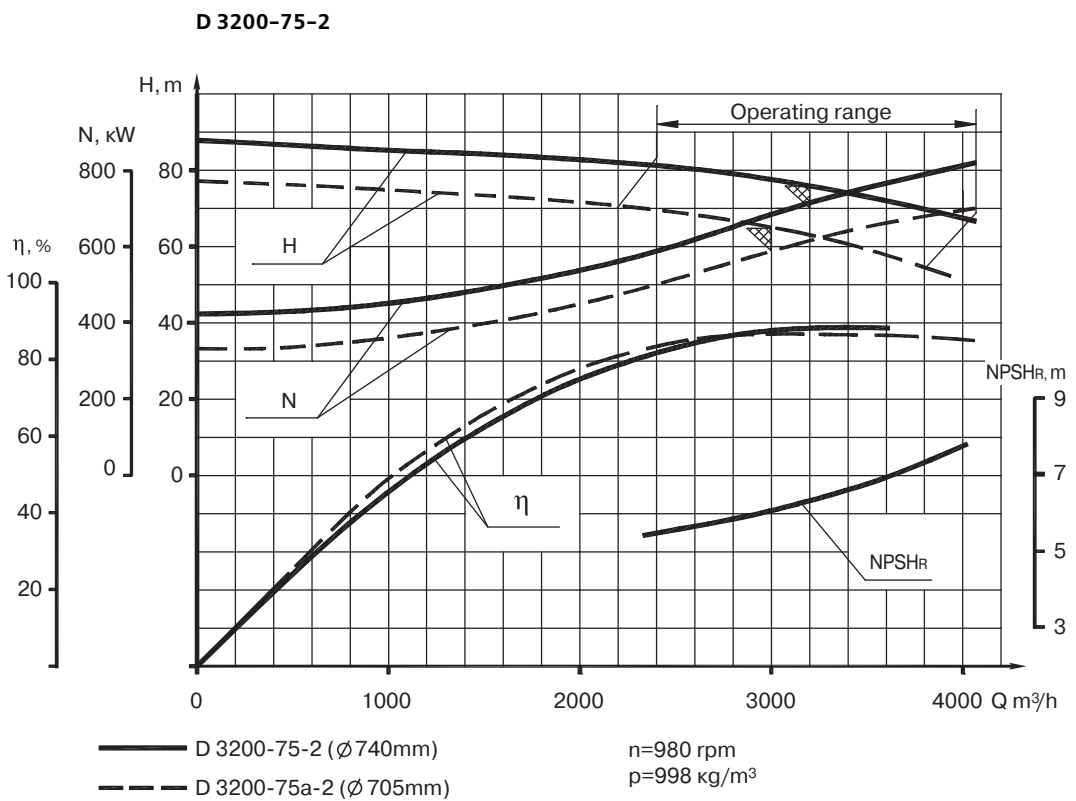
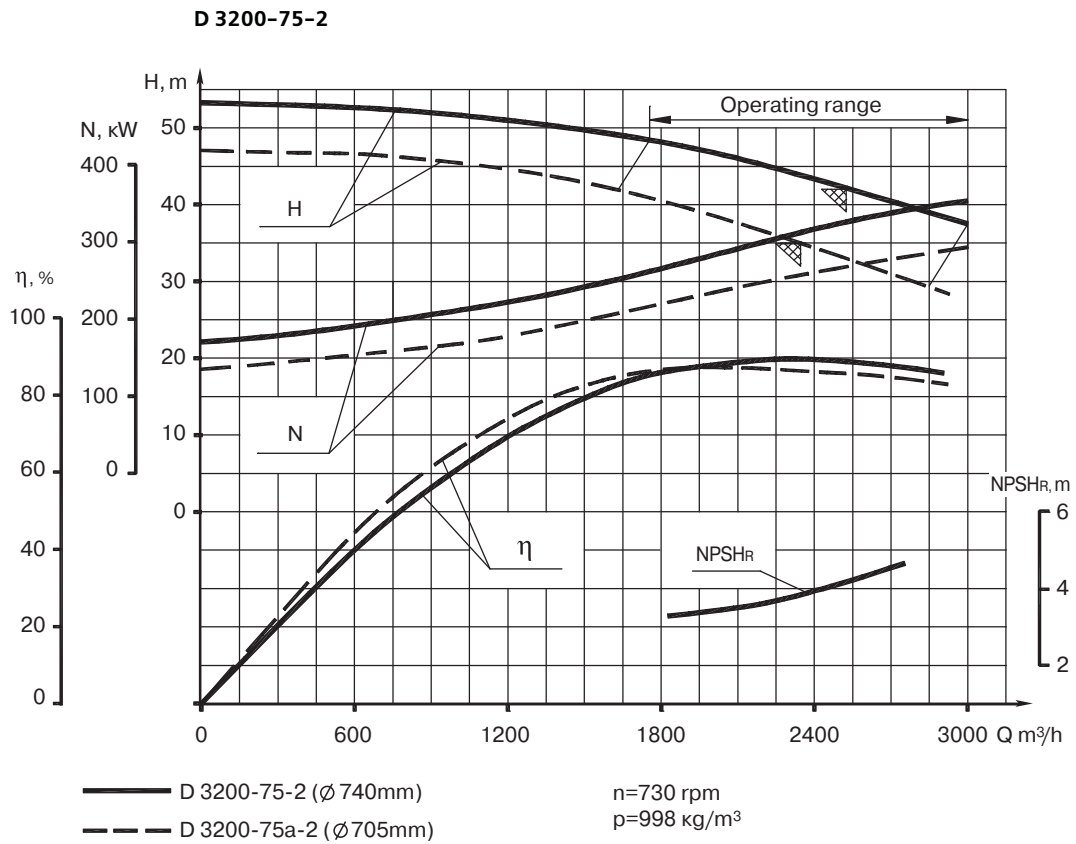

PERFORMANCE CURVE

D 4000-95-2

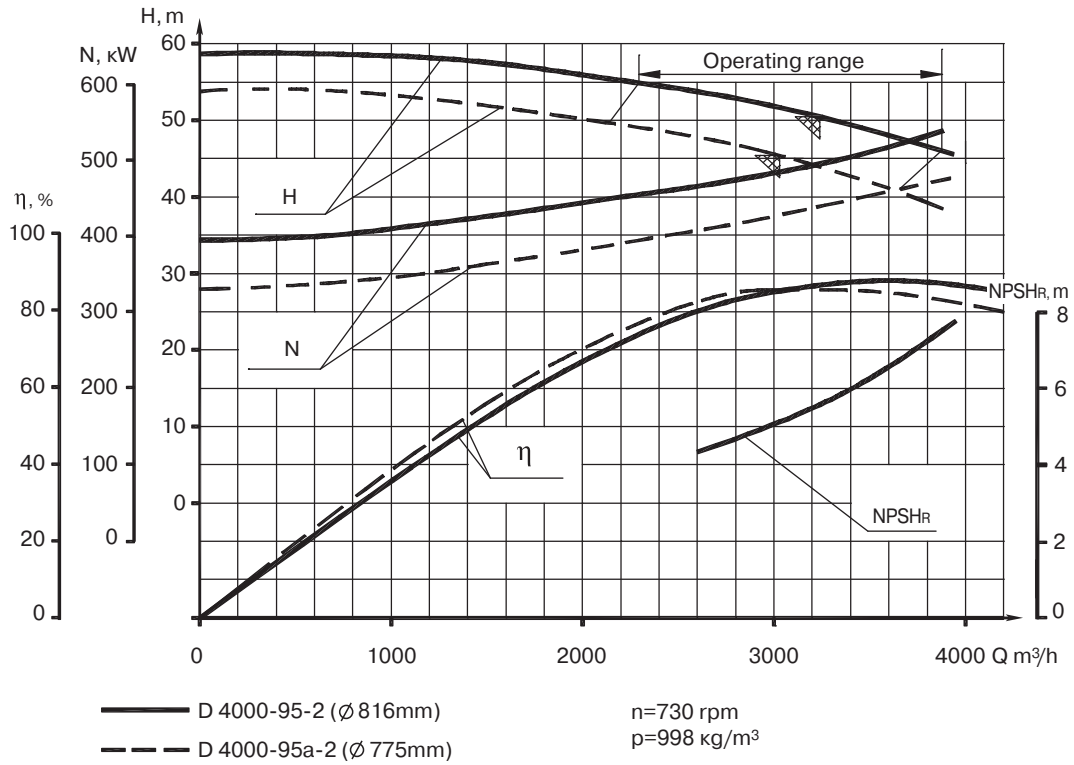

D 4000-95-2

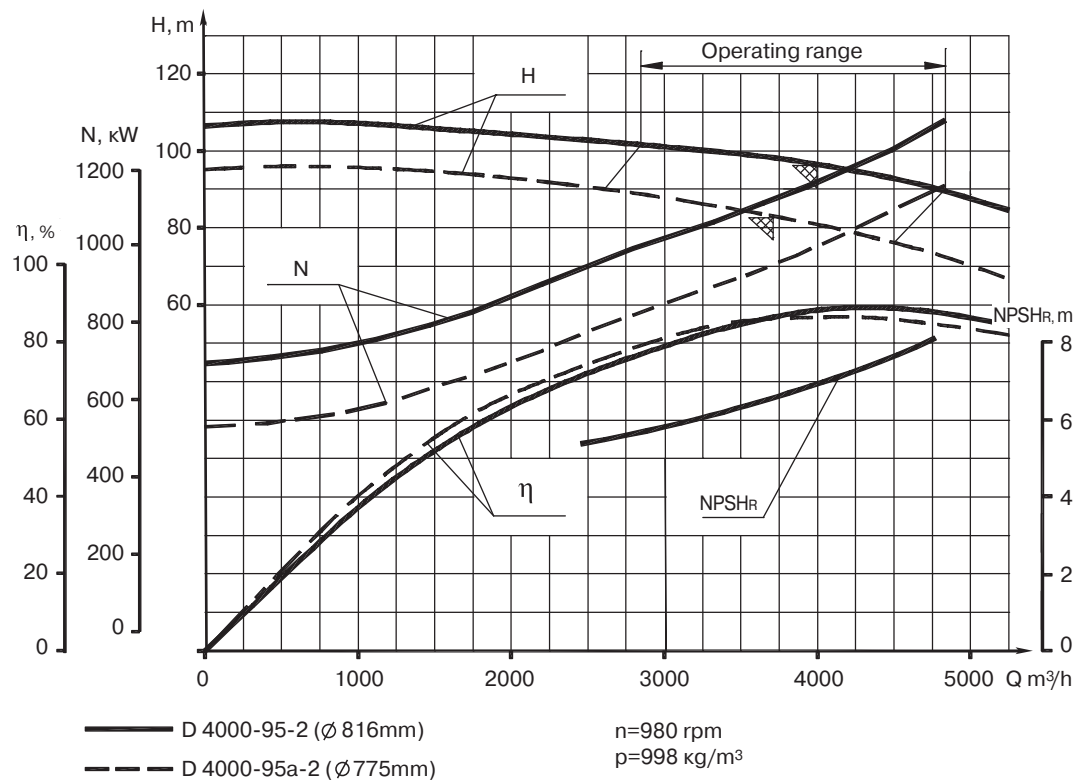

PERFORMANCE CURVE

D 6300-27-3

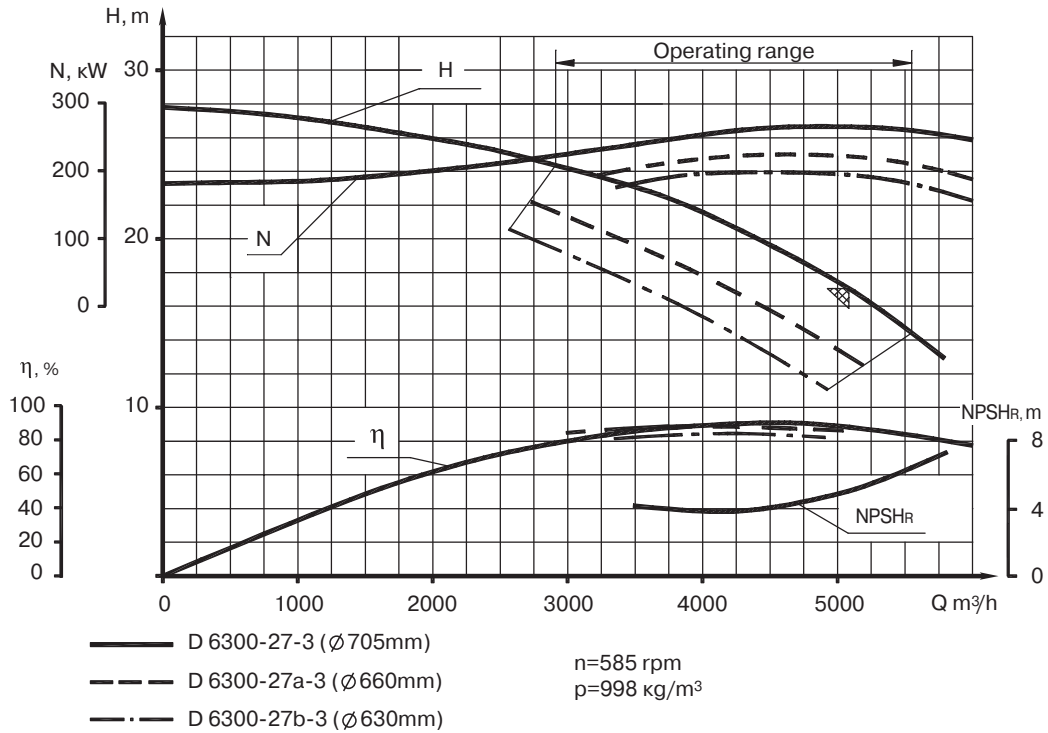

D 6300-27-3

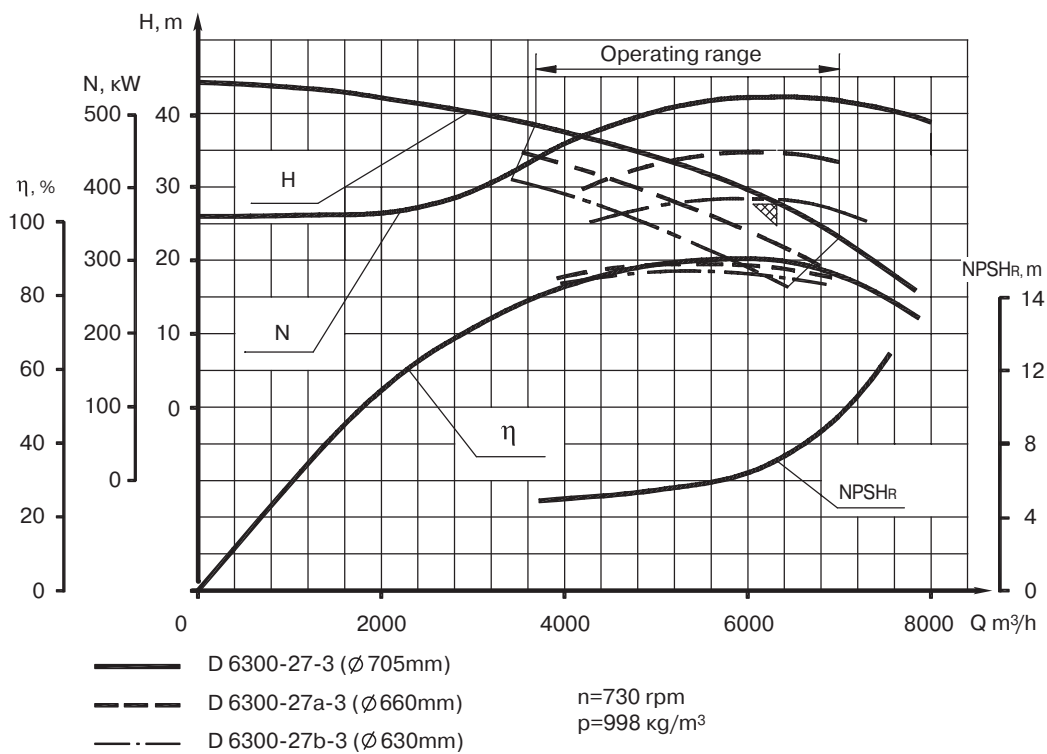

PERFORMANCE CURVE

D 6300-27-3-1

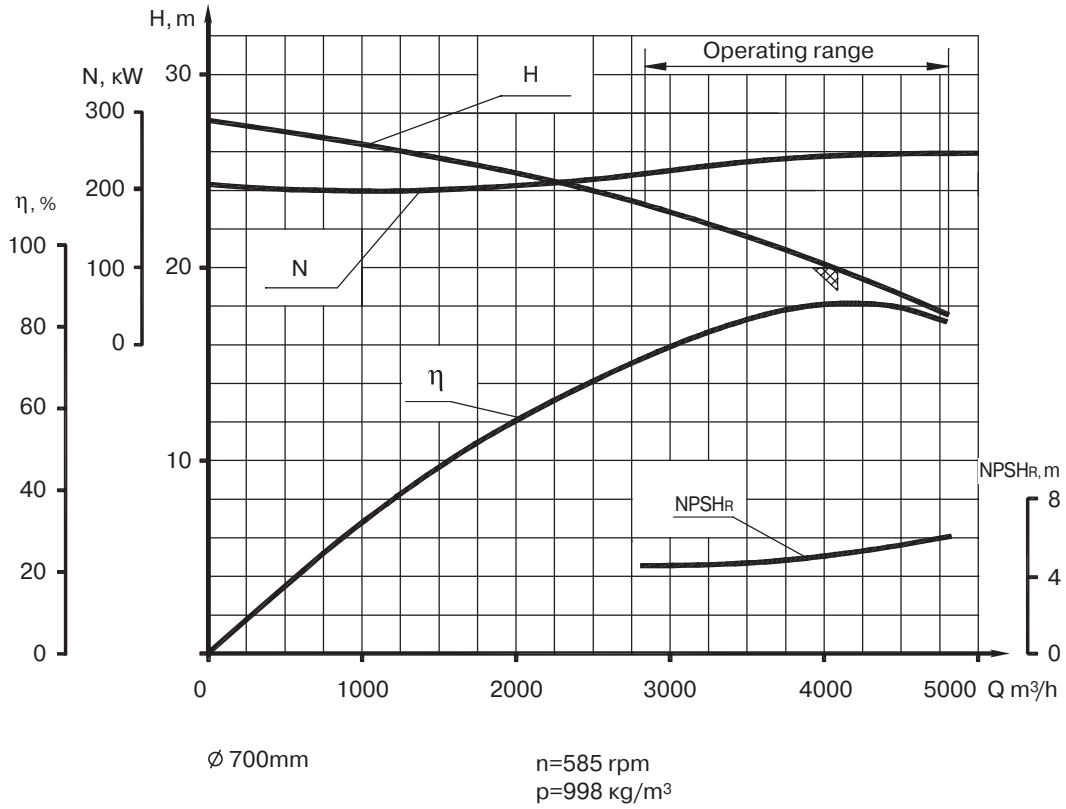

D 6300-27-3-1

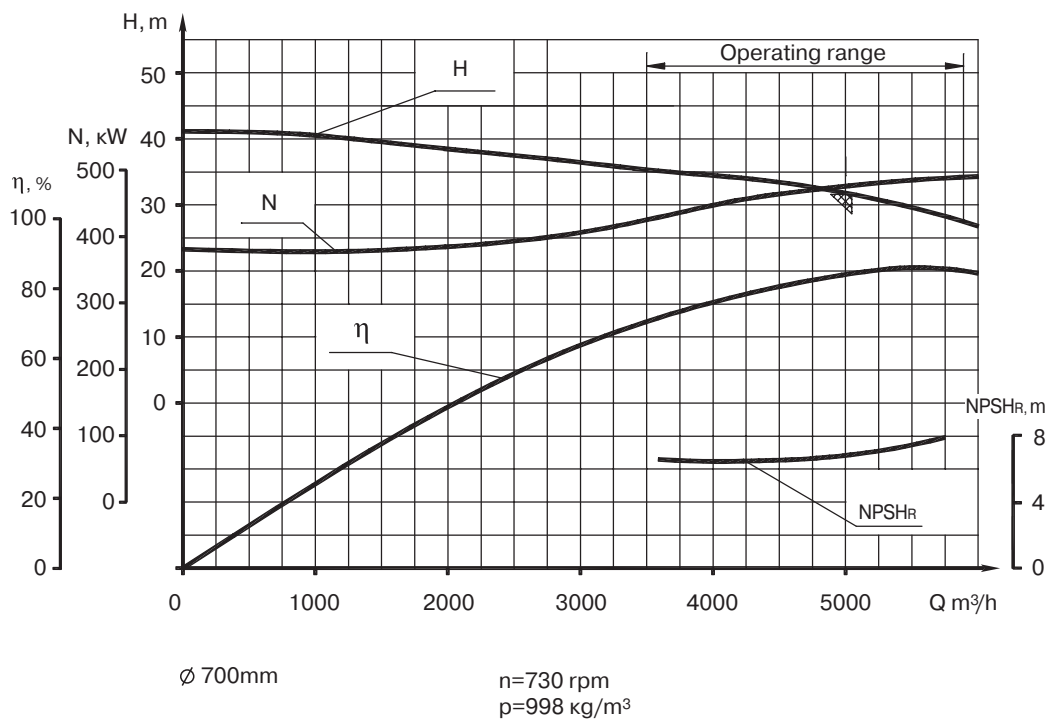

PERFORMANCE CURVE

D 6300-80-2

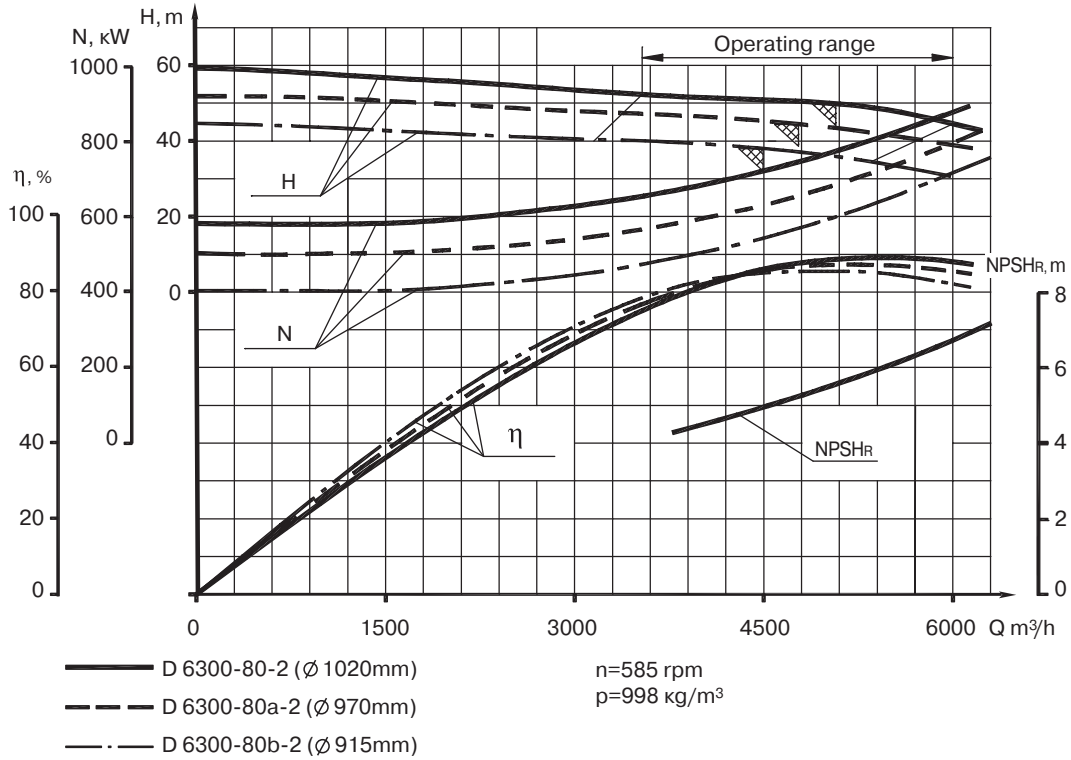

D 6300-80-2

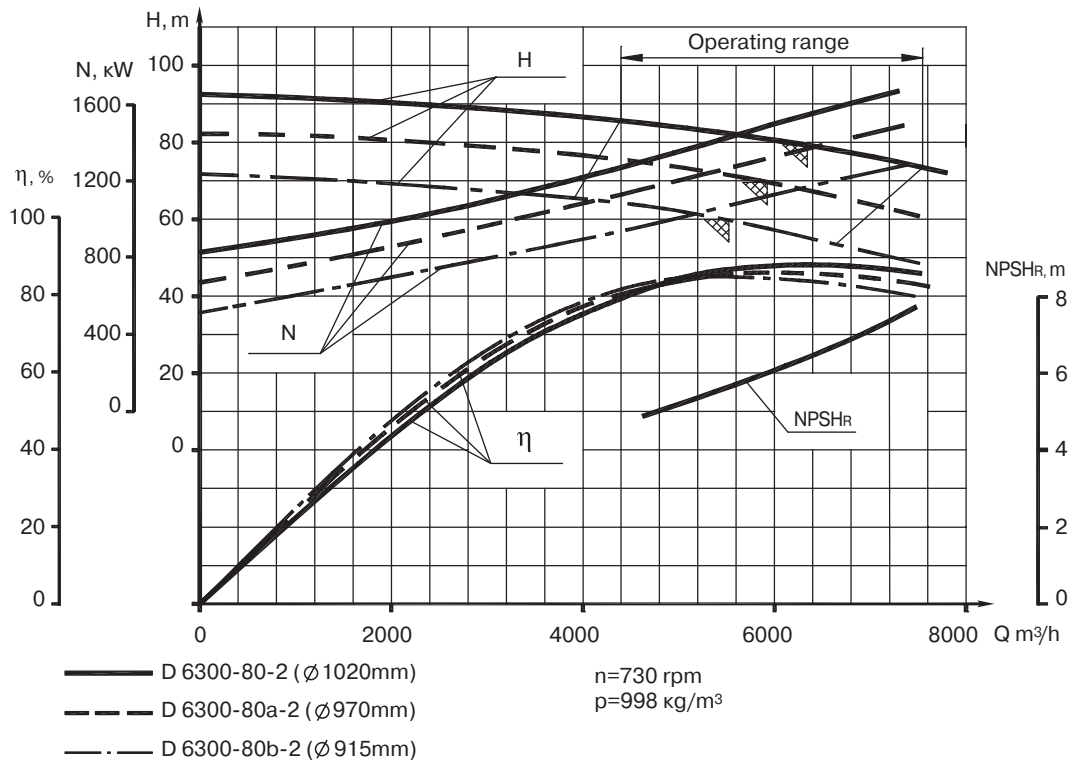

PERFORMANCE CURVE

D 12500-10

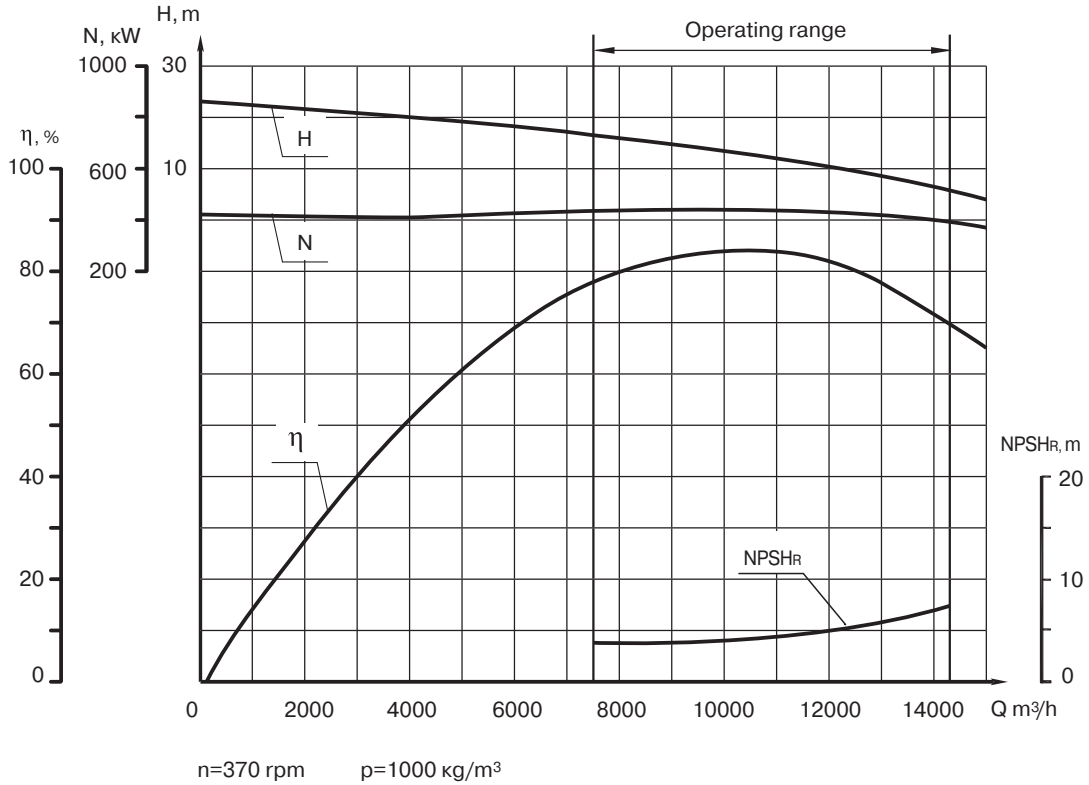

D 12500-24

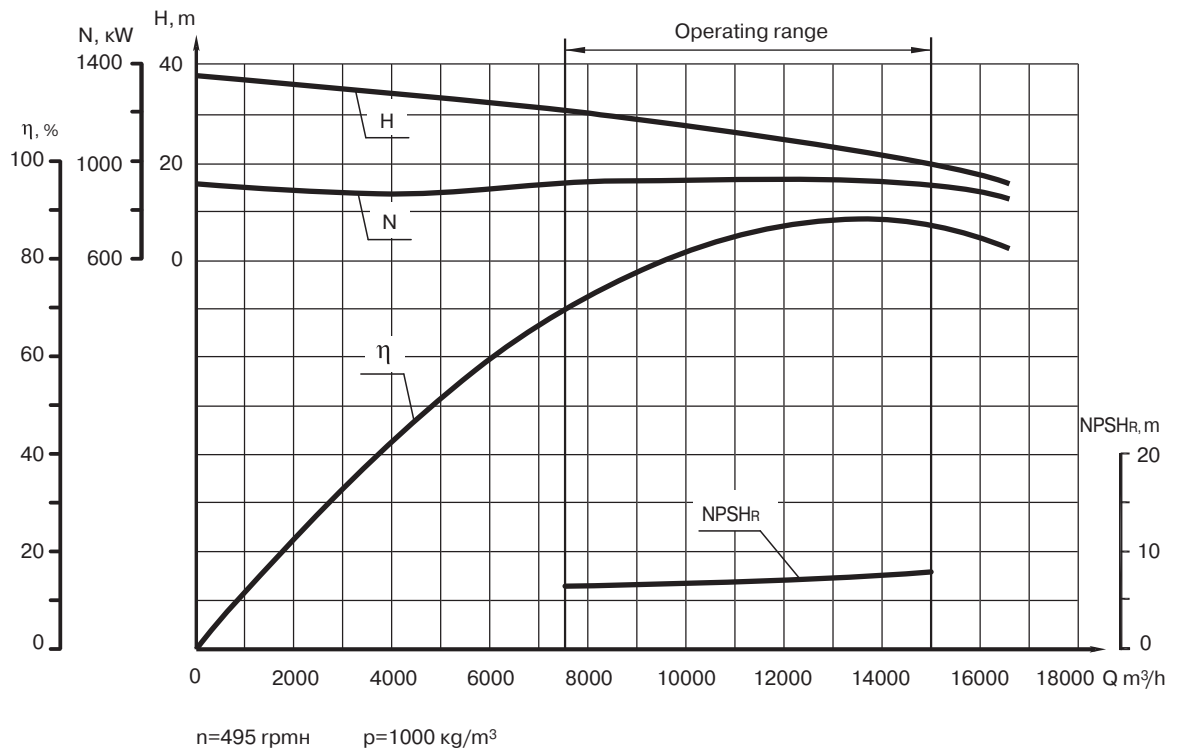

OVERALL DIMENSIONS

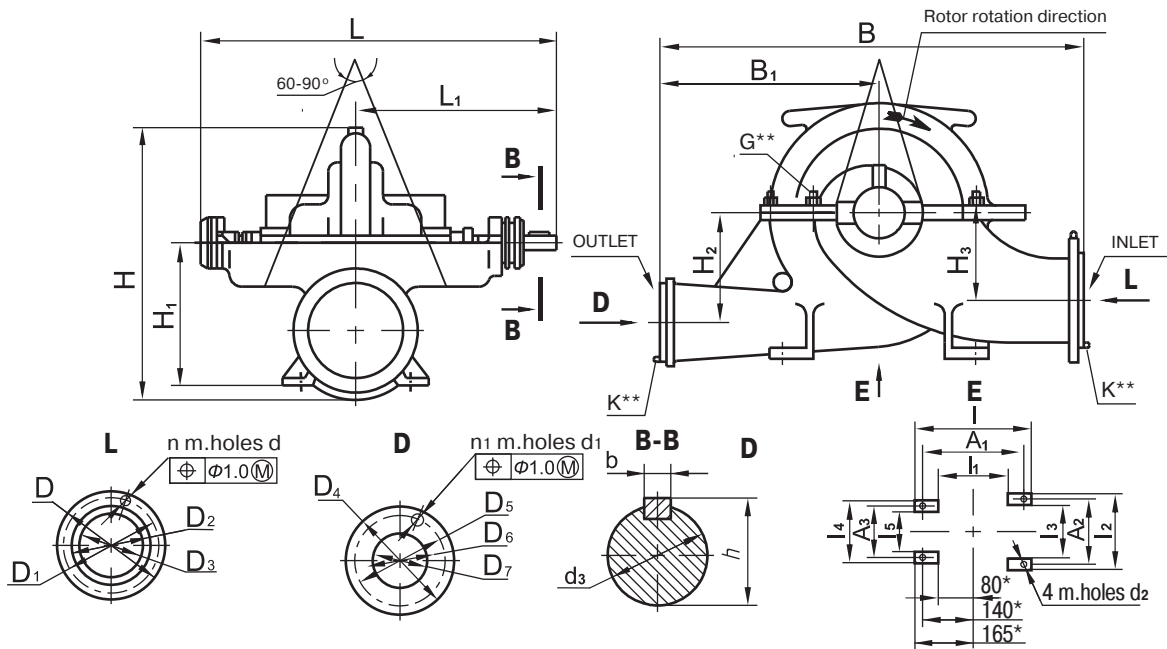

*Dimensions for pumps
1D200-90, 1D250-125, 1D315-50 and 1D315-74

G** — guarantee sealing
K** — conservation sealing

pump model	dimensions in mm													
	L	L ₁	I	I ₁	I ₂	I ₃	I ₄	I ₅	B	B ₁	H	H ₁	H ₂	H ₃
D160-112	790	450	450	210	340	160	340	160	640	300	555	300	181	146
D200-36	830	458	510	300	340	160	340	160	800	373	620	350	224	162
D320-50	830	458	600	350	400	200	400	200	966	474	700	400	260	188
1D200-90	766	420	355	165	370	220	250	100	530	250	495	260	170	170
1D250-125	766	420	355	165	370	220	250	100	550	250	515	260	190	170
1D315-50	766	420	355	165	370	220	250	100	600	300	520	290	170	170
1D315-71	766	420	355	165	370	220	250	100	600	300	520	290	170	170
1D500-63	1145	645	500	260	590	390	360	160	770	350	714	390	280	220
1D630-90	1145	645	590	360	590	390	360	160	1000	500	845	440	330	270
1D630-125	1145	645	590	360	590	390	360	160	900	400	900	470	370	300
1D800-56	1145	645	590	360	590	390	360	160	880	400	835	440	300	240
1D1250-63	1185	665	590	360	590	390	360	160	950	450	897	500	340	300
1D1250-125	1421	782	710	400	710	450	440	180	1050	450	1005	530	400	300
1D1600-90	1421	782	710	400	710	450	440	180	1200	600	1030	530	380	300
2D630-90	1278	695	590	350	590	390	360	160	780	390	650	400	220	220
2D630-125	1278	695	590	350	590	390	360	160	800	400	670	380	220	220
2D2000-21	1590	885	850	450	940	600	630	290	1200	500	1160	710	400	400

pump model	dimensions in mm												
	A ₁	A ₂	A ₃	h	D	D ₁	D ₂	D ₃	D ₄	D ₅	D ₆	D ₇	
D160-112	330±1,6(M)	260±1,6(M)	260±1,6(M)	39-0,29	280	240	212	150	215	180	158	100	
D200-36	430±1,1(M)	260±1,1(M)	260±1,1(M)	35-0,21	260	225	202	150	235	200	178	125	

OVERALL DIMENSIONS

pump model	dimensions in mm											
	A ₁	A ₂	A ₃	h	D	D ₁	D ₂	D ₃	D ₄	D ₅	D ₆	D ₇
D320-50	510±1.1(M)	320±1.1(M)	320±1.1(M)	35-0.21	315	280	258	200	260	225	202	150
1D200-90	270±1.1(M)	320±1.1(M)	200±1.1(M)	39-0.29	260	225	202	150	215	180	158	100
1D250-125	270±1.1(M)	320±1.1(M)	200±1.1(M)	39-0.29	260	225	202	150	215	180	158	100
1D315-50	270±1.1(M)	320±1.1(M)	200±1.1(M)	39-0.29	315	280	258	200	280	240	212	150
1D315-71	270±1.1(M)	320±1.1(M)	200±1.1(M)	39-0.29	315	280	258	200	280	240	212	150
1D500-63	440±1.1(M)	530±1.1(M)	300±1.1(M)	64-0.31	370	335	312	250	280	240	212	150
1D630-90	530±1.1(M)	530±1.1(M)	300±1.1(M)	64-0.31	370	335	312	250	335	295	268	200
1D630-125	530±1.1(M)	530±1.1(M)	300±1.1(M)	64-0.31	370	335	312	250	280	240	212	150
1D800-56	530±1.1(M)	530±1.1(M)	300±1.1(M)	64-0.31	435	395	365	300	335	295	268	200
1D1250-63	530±1.1(M)	530±1.1(M)	300±1.1(M)	64-0.31	485	445	415	350	390	350	320	250
1D1250-125	630±1.1(M)	630±1.1(M)	360±1.1(M)	85-0.31	485	445	415	350	335	295	268	200
1D1600-90	630±1.1(M)	630±1.1(M)	360±1.1(M)	85-0.31	485	445	415	350	460	410	370	300
2D630-90	530±1.1(M)	530±1.1(M)	300±1.1(M)	64-0.31	370	335	312	250	335	295	268	200
2D630-125	530±1.1(M)	530±1.1(M)	300±1.1(M)	64-0.31	370	335	312	250	335	295	268	200
2D2000-21	670±1.1(M)	810±1.1(M)	510±1.1(M)	85-0.31	670	620	585	500	565	515	482	400

pump model	dimensions in mm							P _y ,MPa(kgf/sm ²) inlet/outlet	weight, kg
	d	d ₁	d ₂	d ₃	n	n ₁	b		
D160-112	22	18	23	36js6(±0.008)	8	8	10 $\frac{N9(-0.036)}{h9(-0.036)}$	1.0(10)/1.6(16)	200
D200-36	18	18	23	32js6(±0.008)				0.6(6)/0.6(6)	240
D320-50	18	18	23	32js6(±0.008)				0.6(6)/0.6(6)	300
1D200-90	18	18	24	36js6(±0.008)				0.6(6)/1.6(16)	145
1D250-125	18	18	24	36js6(±0.008)				0.6(6)/1.6(16)	165
1D315-50	18	22	24	36js6(±0.008)				0.6(6)/1.0(10)	190
1D315-71	18	22	24	36js6(±0.008)				0.6(6)/1.0(10)	190
1D500-63	18	22	28	60k6 $_{+0.002}^{+0.021}$	12	8	18 $\frac{N9(-0.043)}{h9(-0.043)}$	0.6(6)/1.0(10)	450
1D630-90	18	22	28	60k6 $_{+0.002}^{+0.021}$	12	12		0.6(6)/1.6(16)	524
1D630-125	18	22	28	60k6 $_{+0.002}^{+0.021}$	12	8		0.6(6)/1.6(16)	797
1D800-56	22	22	28	60k6 $_{+0.002}^{+0.021}$	12	8		0.6(6)/1.0(10)	560
1D1250-63	22	22	28	60k6 $_{+0.002}^{+0.021}$	12	12		0.6(6)/1.0(10)	800
1D1250-125	22	22	35	80k6 $_{+0.002}^{+0.021}$	12	12	22 $\frac{N9(-0.052)}{h9(-0.052)}$	0.6(6)/1.6(16)	1515
1D1600-90	22	26	35	80k6 $_{+0.002}^{+0.021}$	12	12		0.6(6)/1.6(16)	1165
2D630-90	18	22	28	60k6 $_{+0.002}^{+0.021}$	12	12	18 $\frac{N9(-0.043)}{h9(-0.043)}$	0.6(6)/1.6(16)	465
2D630-125	18	22	28	60k6 $_{+0.002}^{+0.021}$	12	12		0.6(6)/1.6(16)	500
2D2000-21	26	26	35	80k6 $_{+0.002}^{+0.021}$	20	16		22 $\frac{N9(-0.052)}{h9(-0.052)}$	1.0(10)/1.0(10)

OVERALL DIMENSIONS & TECHNICAL PARAMETERS

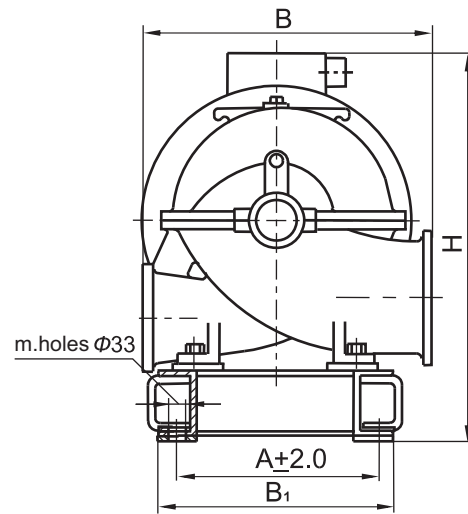
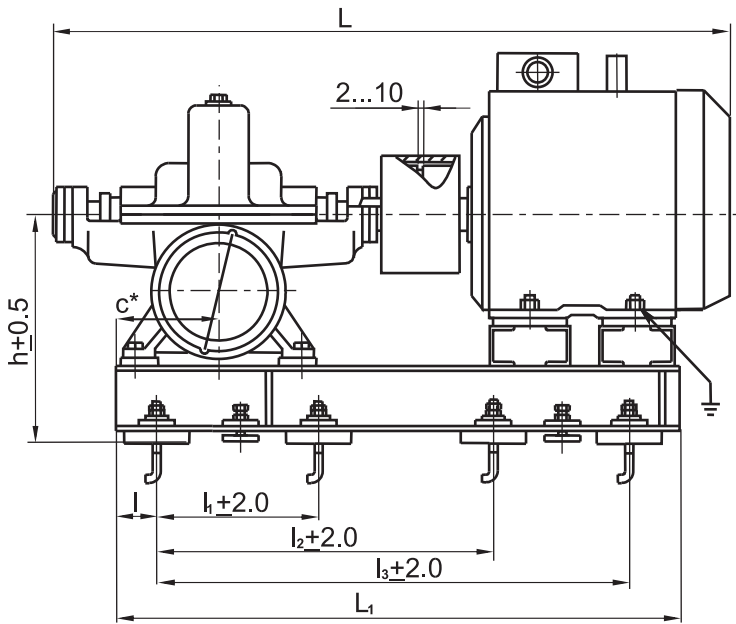

C* (mm)	175	185	215	190	370	485	310
pump model	D160-112	D200-36	D320-50	1D200-90 1D250-125 1D315-50 1D315-71	1D1250-125 1D1600-90	2D200-21	other pumps

pump model	dimensions in mm											n	motor				unit weight, kg	
	L	L ₁	I	I ₁	I ₂	I ₃	B	B ₁	A	H	h		electric motor model	power, kW	voltage, V	weight, kg		
D160-112	1760	1355	175			900				905	525	4	5AM250M2 U3, T2	90	220/380	550	877	
	1465	1080	175	-	-	700	640	510	440	765	520		5A160S4 U3, T2	15		127	467	
	1400	1080	175			700				765	520		AIR160S4 U3, T2	15		120	460	
D160-112a	1730	1355	175			900				905	525	4	5AM250S2 U3, T2	75	220/380	480	847	
	1465	1080	175	-	-	700	640	510	440	765	520		5A160S4 U3, T2	15		127	467	
	1400	1080	175			700				765	520		AIR160S4 U3, T2	15		120	460	
D160-112b	1630	1260	175			900	640	510	440	830	520	4	5A225M2 U3, T2	55	220/380	340	693	
D200-36	1455	1170	185	-	-	800	800	500	400	850	560	4	4AMN180M4U3	37	380	190	557	
	1600	1235				845				5A200M4 U3, T2			37	245		557		
	1585	1235				835				A200M4 U3, T2			37	220/380		230	542	
	1670	1270				835				A200L4 U3, T2			45	220/380		260	547	
D200-36a	1415	1135	185	-	-	800	800	500	440	850	560	4	4AMN180S4U3	30	380	170	535	
	1540	1170				830				A180M4U3, T2			30	220/380		190	557	
	1515	1170				830				AIR180M4U3, T2			30	380		190	557	
D200-36b	1465	1135	185	-	-	800	800	500	440	830	560	4	AIR180S4U3.T2	22	380	170	534	
	1480	1135	185			800	800	500	440	830	560		A180S4Y3,T2	22		220/380	157	525
D320-50	1775	1360	215	-	-	940	970	530	470	990	610	4	5AM250S4U3, T2	75	380	480	955	
	1770	1360	215			940	970	530	470	955	610		A250S4 U3, T2	75		220/380	450	920
D320-50a	1710					940				890	600	4	A225M4 U3,T2	55	220/380	325	785	
	1705	1320	215	-	-	940	970	530	470	910	600		5A225M4 U3.T2	55		380	345	805
	1575					890				955	620		5AN200L4 U3,T2	55		380	290	740
D320-50b	1650	1320	215	-	-	890	970	530	470	920	620	4	5A200L4 U3.T2	45	380	270	745	
	1675	1320	215			890	970	530	470	920	620		A200L4 U3.T2	45		220/380	260	735

OVERALL DIMENSIONS & TECHNICAL PARAMETERS

pump model	dimensions in mm											motor				unit weight, kg	
	L	L ₁	I	I ₁	I ₂	I ₃	B	B ₁	A	H	h	n	electric motor model	power, kW	voltage, V		weight, kg
1D200-90	1740						545			840			5AM250M2 U3, T2	90	380	505	770
	1705	1330				910	530	460	400	805			A250M2 U3, T2	90	220/380	490	755
	1710		190	-	-		545			805	460	4	5AMN250S2 U3	90	380	485	750
	1445	1080				735	530	350	290	705			5A160S4U3, T2	15	220/380	127	365
1405	1080				735	530	350	290	715			AIR160S4U3, T2	15	220/380	120	360	
1565	1190				780	530	350	290	705			4ANM180MO4	15	220	179,5	410	
1710	1330				910	545	460	400	840			5AM250S2 U3, T2	75	380	475	740	
1705	1330	190	-	-	910	530	460	400	805	460	4	A250S2 U3, T2	75	220/380	450	715	
1525	1270				820	530	360	300	750			5AN200L2U3, T2	75	380	280	525	
1610	1235				840		450	380	790	480		5A225M2 U3, T2		380	340	605	
1615	1235				840		450	380	745	480		A225M2 U3, T2	55	220/380	320	585	
1495	1205	190	-	-		530	360	300	745		4	5AN200M2 U3, T2		380	250	500	
1555	1240				820				735	460		5A200L2 U3, T2		380	255	500	
1575	1240								750			A200L2 U3, T2	45	220/380	255	500	
1395	1125				780		350	290	750			4AMN180M2U3		380	185	430	
1932	1500					895	630	510	985	535		5AM315S2U3, T2		380	970	1287	
1972	1500	190	-	-		590	630	510	880	535	4	A315S2U3, T2		220/380	905	1225	
1852	1490				990		620	520	880	500		5AMN280M2U3	160	380	770	1080	
1628	1490					665	520	450	965	500		5AN280A2U3, T3		380	744	1042	
1852	1490	190	-	-	990	620	520	450	880	500	4	5AM280M2U3, T2	132	380	770	1080	
1822	1490	190	-	-	990	550	520	450	845	500	4	A280M2 U3, T2	132	220/380	620	943	
1707	1325				890		470	400	890	510		5AM250S2 U3, T2		380	475	788	
1702	1325	190	-	-	890	600	470	400	895	510	4	A250S2 U3, T2	75	220/380	450	750	
1522	1265				820		360	300	790	500		5AN200L2 U3, T3		380	280	580	
1607	1255				840		440	370	805	495		5A225M2 U3, T2		380	340	650	
1612	1255	190	-	-	840	600	440	370	760	495	4	A225M2 U3, T2	55	220/380	320	630	
1492	1235				820		360	300	790	500		5AN200M2 U3, T3		380	250	549	
1553	1235				820				785			5A200L2 U3, T2		380	255	554	
1577	1235	190	-	-	820	600	360	300	775	500	4	A200L2 U3, T2	45	220/380	255	554	
1392	1130				780				790			4AMN180M2U3		380	185	474	

OVERALL DIMENSIONS & TECHNICAL PARAMETERS

pump model	dimensions in mm											motor				unit weight, kg	
	L	L ₁	l	l ₁	l ₂	l ₃	B	B ₁	A	H	h	n	electric motor model	power, kW	voltage, V		weight, kg
1D315-71	1737	1325				890	600	470	400	890			5AMN250M2 U3		380	530	843
	1852	1400	190	-	-	940	620	520	450	890	510	4	5AM280S2 U3, T2	110	380	720	1045
	1822	1400				940	620	520	450	855			A280S2 U3, T2		220/380	590	915
1D315-71a	1737	1325								890			5AM250M2 U3, T2		380	505	818
	1702	1325	190	-	-	890	600	470	400	855	510	4	A250M2 U3, T2	90	220/380	490	803
1D500-63	1707	1325								890			5AMN250S2 U3		380	485	798
	2445	1895						630	570	1065	615		5AM315S4 V3, T2			1110	1850
1D500-63a	2335	1830	310	-	620	1240	770	530	470	1000	620	6	5AMN280M4 U3	160	380/660	835	1510
	2040	1885						530	470	1205	620		5AN280B4 U3, T3			764	1445
	2265	1830								1000			5AMN280S4 U3			756	1430
1D500-63b	2290	1830	310	-	620	1240	770	530	470	965	620	6	A280M4 U3, T2	132	380/660	700	1360
	2040	1885								1205			5AN280A4 U3, T3			720	1400
	2265	1830						530	470	1000	620		5AM280S4 U3, T2			780	1455
	2175	1830	310	-	620	1240	770	530	470	965	620	6	A280S4 U3, T2	110	380/660	570	1230
1D630-90	2120	1670				570	1140	500	440	1000	610		5AMN250M4 U3			540	1175
	2090												5AMN250-S4 U3			490	1125
	2120	1670	310	-	570	1140	770	500	440	1000	610	6	5AM250-M4 U3, T2	90	220/380	515	1150
	2105												5A250-M4 U3, T2			525	1160
1D630-90	2145									955			A250-M4 U3, T2			550	1185
	2930	2435	200	650	1300	1950	1320	885	800	1580	710	8	DA3O4 400XK-4M Y1	315		2190	3050
	2930	2435	200	650	1300	1950	1320	885	800	1580	710	8	DA3O4 400X-4M T2	315	6000	2330	3050
	2360	2125			700	1400	1090	720	660	1535			A4-355-L4 U3, T3			1250	2070
	2445	1960								1115			5AMN315-M4U3	250	380/660	1050	1940
	2195	1930			630	1250	1000	600	540	1175			5AN315-B4U3, T3			990	1780
	2250	2065								1200			DAN315-M4U3			970	1775
	2580	2290	310	-	700	1400	1090	720	660	1110	665	6	DAV250-4 U3		6000	1420	2260
	2345	1960			630	1250				1115			5AM315 S6U3, T2	110		960	1750
	2040												5AN280B-6 U3, T3	110		732	1500
2265	1905			570	1140	1000	600	540	1070			5AMN280-S6 U3		380/660	715	1480	
2265												5AM280M-6 U3, T2	90		780	1545	
2040												5AN280A-6 U3, T2			700	1470	

OVERALL DIMENSIONS & TECHNICAL PARAMETERS

pump model	dimensions in mm											motor				unit weight, kg	
	L	L ₁	I	I ₁	I ₂	I ₃	B	B ₁	A	H	h	n	electric motor model	power, kW	voltage, V		weight, kg
1D630-90a	2360	2125			700	1400	1090	720	660	1535			A4-355-LK-4 U3, T3		6000	1200	2025
	2445	1960							1115				5AMN315-S4U3			1050	1845
	2445	1960			630	1250			1115				5AM315M4U3, T2	200		1110	1945
	2195	1930	310	-					1175		655	6	5AN315A-4U3, T3		380/660	900	1960
	2200	2015					1000	600	540	1200			DAN315-S4U3			870	1675
	2265	1905											5AM280-S6 U3, T2			745	1510
1D630-90b	2175	1905			570	1140			1070				A280S6 U3, T2	75		570	1335
	2120	1695											5AMN250-M6 U3		220/380	475	1200
	2445	1960			630	1250			1115				5AM315-S4 U3, T2			1110	1905
	2335	1905							1070				5AMN280-M4 U3	160		835	1600
	2040	1905	310	-	570	1140	1000	600	540	1130	655	6	5AN280-B4 U3, T3			764	1530
	2120	1695							1070				5AM250-M6 U3, T2	55	220/380	450	1200
1D630-125	2085	1695							1070				A250-M6 U3, T2	55	220/380	455	1205
	2330	2065	310	-	700	1345	910	625	530	1725	750	6	5AN355-B4 U3, T3		380/660	1400	2500
	2805	2260	310	-	700	1345	1090	625	530	1265	750	6	A4-355Y-4 U3, T3		6000	1730	2845
	2705	2395	200	650	1300	1950	1320	885	800	1650	750		A4-400XK-4M U3	400	6000	1930	3095
	2905	2590	200	700	1400	2100	1540	1005	920	1755	770	8	A4-85/37K-4 U3		10000	2600	3775
	2930	2415	200	650	1300	1950	1320	885	800	1620	750		DA304-400X-4M Y1		6000	2330	3495
1D630-125a	3130	2590	200	700	1400	2100	1540	1005	920	1795	770		DA304-85/37-4 Y1		10000	2820	4000
	2330	2065	310	-	700	1345	910	625	530	1725		6	5AN355-A4 U3, T3		380/660	1290	2395
	2715	2160	310	-	700	1345	1090	625	530	1265		6	A4-355X-4 U3, T3		6000	1450	2560
	2930	2415	200	650	1300	1950	1320	885	800	1620	750	8	DA304-400XK-4M Y1		6000	2190	3360
	2385	2185	310	-	700	1345	1040	625	530	1445		6	DAN-355S-4 U3	315	380/660	1270	2390
	2575	2365	310	-	700	1345	1140	625	530	1195		6	DAB-315-4U3		6000	1450	2570
1D630-125b	3130	2590	200	700	1400	2100	1540	1005	920	1795	770	8	DA304-85/37K-4 Y1		10000	2820	4000
	2595	1935					900			1195	745		5AMN315-M4U3		380/660	1145	2235
	2195	1935					900			1245	745		5AN315-B4U3, T3		380/660	990	2080
	2635	2090	310	-	700	1345	1090	625	530	1265	750	6	A4-355L-4 U3, T3	250	6000	1250	2355
	2250	2055					900			1280	745		DAN-315-M4U3		380/660	970	2075
	2575	2365					1140			1195	750		DAV-250-4 U3		6000	1420	2570

OVERALL DIMENSIONS & TECHNICAL PARAMETERS

pump model	dimensions in mm											motor				unit weight, kg		
	L	L ₁	I	I ₁	I ₂	I ₃	B	B ₁	A	H	h	n	electric motor model	power, kW	voltage, V		weight, kg	
1D800-56	2306	2125			700	1400	990	720	660	1535				A4-355-LK4 U3, T3		6000	1200	2050
	2595	1960							1115				5AMN315-S4U3			1050	1870	
	2595	1960	310	-	630	1250	880	600	540	1115	665	6	5AM315-M4U3, T2	200	380/660	1150	1970	
	2195	1930								1165			5AN315-A4U3, T3			900	1710	
	2200	2015								1165			DAN315-S4U3			870	1695	
	2385									1045			5AMN280-S4 U3			756	1545	
1D800-56a	2040	1905	310	-	570	1140	880	600	540	1130	665	6	5AN280-A4 U3, T3	132	380/660	720	1505	
	2325								1045				A280-M4 U3, T2			700	1485	
1D800-56b	2415	1905											5AM280-S4 U3, T2			780	1565	
	2325	1905	310	-	570	1140	880	660	540	1045	665	6	A280-S4 U3, T2	110	380/660	570	1355	
	2270	1695											5AMN250-M4 U3			540	1310	
	2370	2064											5AN355-A4 U3, T3			1290	2485	
	2670	2385	310	-	700	1400	1050	720	650	1175	690	6	DAV-315-4U3			1450	2583	
	2425	2205								1425	690		DAH355-S4 U3	315	380/660	1270	2387	
1D1250-63	2970	2415	200	650	1300	1950	1320	885	800	1640	770	8	DA304-400XK-4M U1			2190	3385	
	2755	2210			700	1400	1040	720	650	1280	690		A4-355X-4 U3, T3			1450	2558	
	2535	1970	310	-	620	1265				1175	725	6	5AM315-S6U3, T2			960	2045	
	2545	1840			620	1265	950	600	540	1080	725		A315-S6U3, T2	110	380/660	750	1795	
	2080	1890			600	1200				1195	730		5AN280-V6 U3, T3			732	1742	
	2670	2385			700	1400	1050	720	650	1175	690		DAV-250-4 U3			1420	2583	
1D1250-63a	2290	2075								1260			DAN-315-M4U3			970	2062	
	2235	1920			620	1265	950	600	540	1225	725		5AN315-V4U3, T3	250	380/660	990	2070	
	2635	1970	310	-						1175		6	5AMN315-M4U3			1145	2230	
	2675	2130			700	1400	1040	720	650	1280	690		A4-355L-4 U3, T3			1250	2352	
	2455	1890			600	1200	950	600	540	1110	730		5AM280-S6 U3, T2	75	380/660	430	1755	
	2425	1780			600	1245	950	600	540	1085	730		A280-S6 U3, T2	75	380/660	570	1712	
1D1250-63b	2635	1970								1175			5AM315-M4U3, T2			1150	2235	
	2635	1970			620	1265	950	600	540	1175	725		5AMN315-S4U3			1050	2135	
	2235	1920								1225			5AN315-A4U3, T3	200		900	1980	
	2675	2130	310	-	700	1400	1040	720	650	1280	690	6	A4-355LK-4 U3, T3			1200	2300	
	2240	2025			620	1265				1260	725		DAN-315-S4U3			970	1960	
	2280	1710			600	1150	950	600	540	1110	730		5AM250-M6 U3, T2	55	220/380	450	1464	
2260	1710			600	1150				1085	730		A250-M6 U3, T2	55	220/380	455	1435		

OVERALL DIMENSIONS & TECHNICAL PARAMETERS

pump model	dimensions in mm													motor				unit weight, kg
	L	L ₁	l	l ₁	l ₂	l ₃	B	B ₁	A	H	h	n	electric motor model	power, kW	voltage, V	weight, kg		
1D1250-125	3255	2655		700	1400	2100	1420			1835			DA304-450H-4M U1		6000	2900	4830	
	3180	2810	250	720	1440	2160	1540	1005	920	1795	810	8	A4-85/43-4 U3	630	10000	2800	4700	
	3526	2930		800	1600	2400	1540			1835			DA304-85/49-4 U1		10000	3325	5335	
1D1250-125a	2980	2615	250	700	1400	2100	1320	985	900	1700	800	8	A4-400H-4M U3	500	6000	2070	4015	
	3305	2715	250	700	1400	2100	1320	985	900	1670	800	8	DA304-400U-4M U1	500	6000	2630	4540	
1D1250-125b	2980	2615	250	700	1400	2100	1320	985	900	1700	800	8	A4-400HK-4M U3	400	6000	1930	3875	
	2605	2240	370	-	700	1500	1200	715	630	1345	800	6	5AN355-B4 U3, T3	400	380/660	1400	3300	
1D1600-90	3255	2655		700	1400	2100	1420			1835			DA304-450H-4M U1		6000	2900	4830	
	3180	2810	250	720	1440	2160	1540	1005	920	1795	810	8	A4-85/43-4 U3	630	10000	2800	4350	
	3526	2930		800	1600	2400	1540			1835			DA304-85/49-4 U1		10000	3325	4985	
1D1600-90a	2470	2100	370	-	700	1400	1200	715	630	1305	805	6	5AN315-B6U3, T3	160	380/660	980	2470	
	2980	2615								1700			A4-400H-4M U3	500		2070	3665	
	3305	2715	250	700	1400	2100	1320	985	900	1670	800	8	DA304-400U-4M U1	500	6000	2630	4225	
1D1600-90b	2980	2615								1700			A4-400HK-4M U3	400		1930	3525	
	2605	2240	370	-	700	1500	1200	715	630	1345		6	5AN355-B4 U3, T3	400	380/660	1400	2950	
	2470	2100	370	-	700	1400	1200	715	630	1305	805	6	5AN315-A6U3, T3	132	380/660	900	2395	
1D1600-90b	2605	2240	370	-	700	1500	1200	715	630	1345	800	6	5AN355-A4 U3, T3	315	380/660	1290	2790	
	3205	2615	250	700	1400	2100	1320	985	900	1670	800	8	DA304-400HK-4M U1	315	6000	2190	3785	
	2620	2100	370	-	700	1400	1200	715	630	1305	805	6	5AM315-S6U3, T2	110	380/660	960	2495	
2D2000-21	2436	2065	370	-	700	1400	1200	690	630	1260	760	6	5AN280-B6 U3, T3	110	380/660	732	2185	
	2790	2345								1435			5AMN315-M6U3	160		1005	2975	
	2640	2345								1485			5AN315-B6U3, T3	160		980	2945	
2D2000-21	2710		485	-	800	1450	1200	765	670	1405	980	6	5AM280-M8 U3, T2		380/660	790	2710	
	2710	2300								1405			5AMN280-S8 U3	75		705	2625	
	2605									1450			5AN280-A8 U3, T3			743	2655	
2D2000-21a	2790	2345								1435			5AM315-S6U3, T2	110		960	2930	
	2605	2300	485	-	800	1450	1200	765	670	1450	980	6	5AN280-B6 U3, T3	110	380/660	732	2645	
	2605	2300								1450			5AM280-S8 U3	55		725	2640	

OVERALL DIMENSIONS

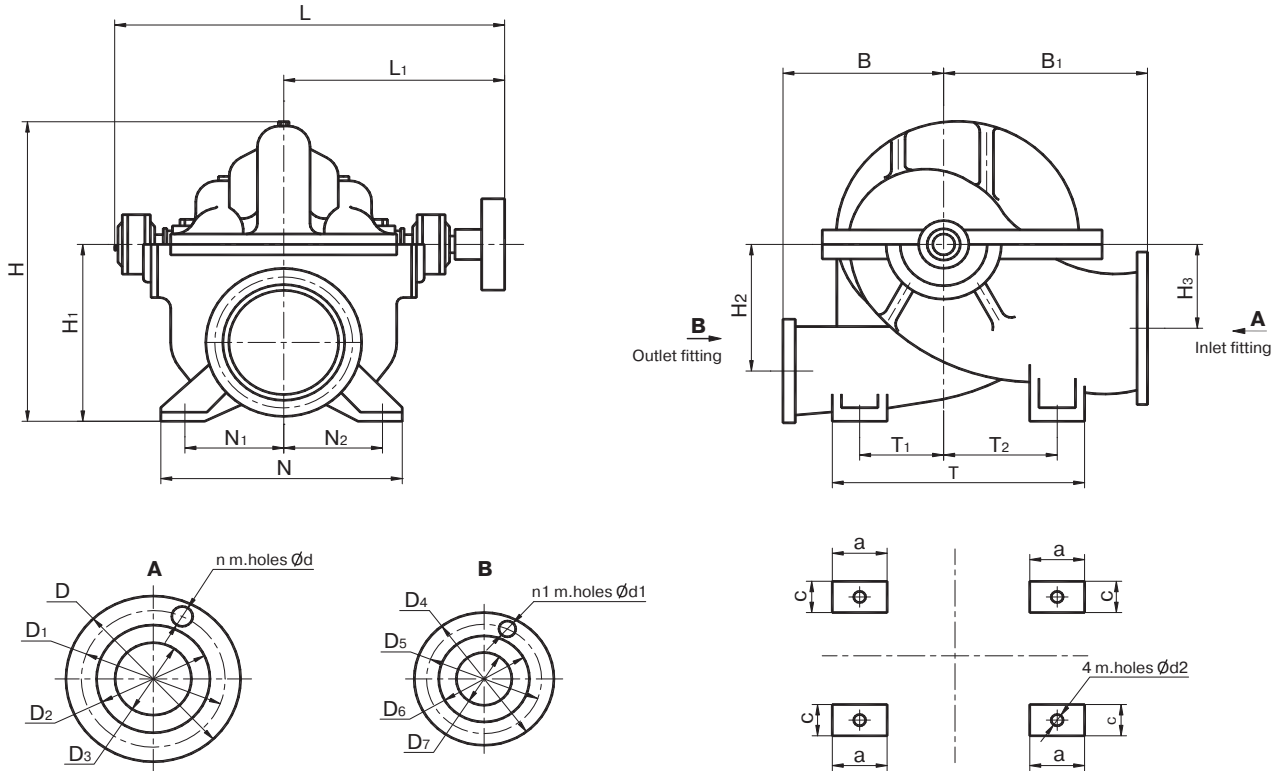

pump model	dimensions in mm										
	L	L ₁	B	B ₁	H	H ₁	H ₂	H ₃	d	d ₁	d ₂
D630-90-2											
D630-90a-2	1190	645	500	500	865	440	330	270	19	24	28
D630-90b-2											
D2000-21-2											
D2000-21a-2	1440	795	500	850	1285	760	440	460	20	26	35
D2000-21b-2											
D2000-100-2											
D2000-100a-2	1800	1010	800	750	1405	800	565	415	33	26	42
D2000-100b-2											
D2500-62-2											
D2500-62a-2	1850	1025	770	900	1420	850	620	475	33	30	42
D3200-33-2											
D3200-33a-2	1890	1025	740	1020	1520	940	525	550	26	30	35
D3200-33b-2											
D3200-75-2											
D3200-75a-2	2000	1100	740	1000	1590	950	642	532	35	30	42
D4000-95-2											
D4000-95a-2	2260	1260	1100	1100	1756	1050	758	595	33	33	45

OVERALL DIMENSIONS

pump model	dimensions in mm										
	L	L ₁	B	B ₁	H	H ₁	H ₂	H ₃	d	d ₁	d ₂
D6300-27-3	2000	1085	750	1200	1950	1210	660	690	35	30	42
D6300-27-3-1											
D6300-27a-3											
D6300-27b-3											
D6300-80-2	2880	1490	1100	1285	2195	1330	880	700	35	35	52
D6300-80a-2											
D6300-80b-2											

pump model	dimensions in mm																	
	n	n ₁	D	D ₁	D ₂	D ₃	D ₄	D ₅	D ₆	D ₇	T	T ₁	T ₂	N	N ₁	N ₂	a	c
D630-90-2	12	12	370	335	312	250	335	295	268	200	590	275	275	590	275	275	120	120
D630-90a-2																		
D630-90b-2																		
D2000-21-2	20	16	670	620	585	500	565	515	482	400	800	300	300	800	330	330	200	160
D2000-21a-2																		
D2000-21b-2																		
D2000-100-2	20	12	710	650	585	500	480	410	370	300	1200	515	465	800	340	340	220	150
D2000-100a-2																		
D2000-100b-2																		
D2500-62-2	20	16	710	650	585	500	580	525	482	400	1100	425	425	110	450	450	250	250
D2500-62a-2																		
D3200-33-2	20	20	780	725	685	600	670	620	585	500	1760	360	360	940	390	390	240	200
D3200-33a-2																		
D3200-33b-2																		
D3200-75-2	20	16	840	770	685	600	580	525	482	400	1250	500	500	1100	450	450	250	250
D3200-75a-2																		
D4000-95-2	20	20	840	770	685	600	710	650	585	500	1500	600	600	1200	500	500	300	250
D4000-95a-2																		
D6300-27-3	24	20	1020	950	905	800	780	725	685	600	1200	450	450	1200	500	500	250	300
D6300-27-3-1																		
D6300-27a-3																		
D6300-27b-3																		
D6300-80-2	24	20	1020	950	905	800	840	770	685	600	1700	675	675	1300	500	500	350	300
D6300-80a-2																		
D6300-80b-2																		

OVERALL DIMENSIONS

D12500-24M, D12500-10M

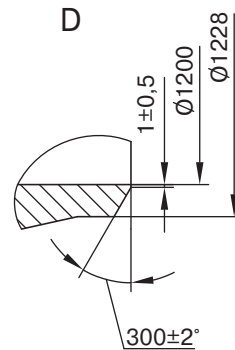
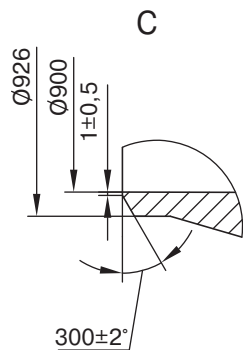
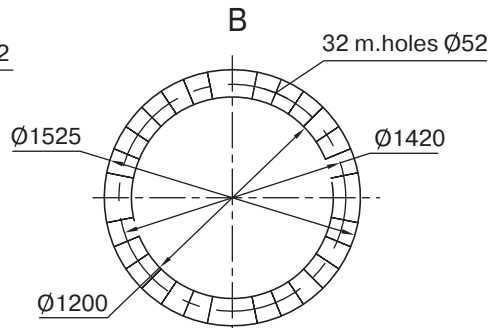
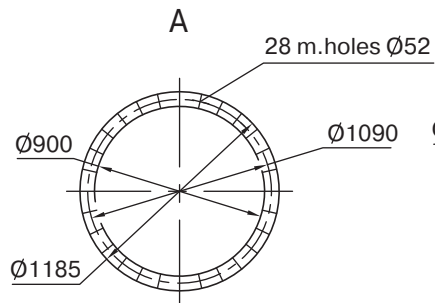
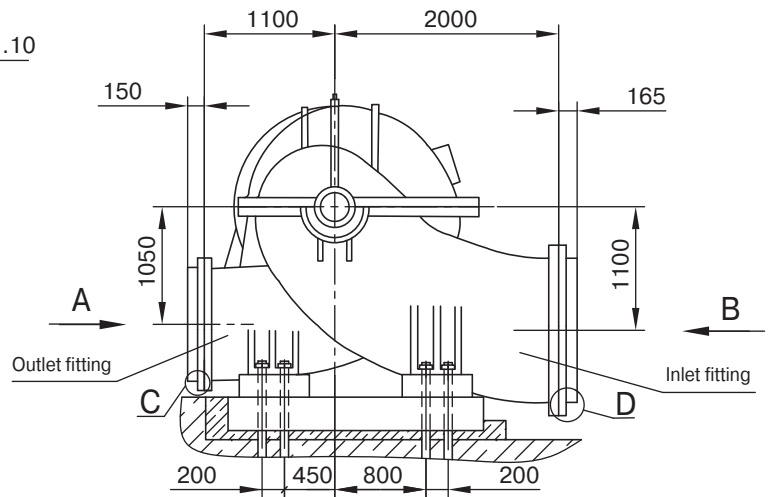
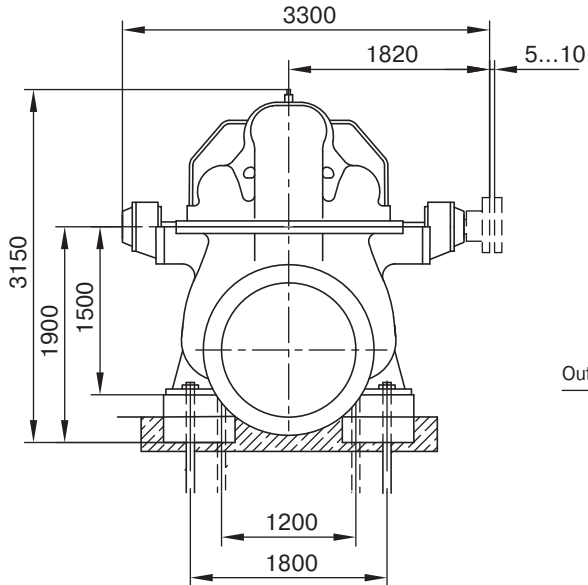

DIESEL-DRIVEN PUMP UNITS OF DNA TYPE

APPLICATION

Diesel driven pump units of **DNA** type are intended for pumping of water and other liquids with the viscosity properties and chemical activity similar to water, with the dry solids content not more than 0,05% by weight, with the size not more than 0.2 mm. The pumped liquid temperature is from 274 to 358K (from 1 to 85 °C).

Climatic version UHL (moderate cold), location category 3.1 under GOST 15150. Upon customer's request the units can be manufactured in other climatic version and location category.

Diesel driven pump units may be used in fire extinguishing systems.

Diesel driven pump units are not intended for use in explosion and fire hazardous premises.

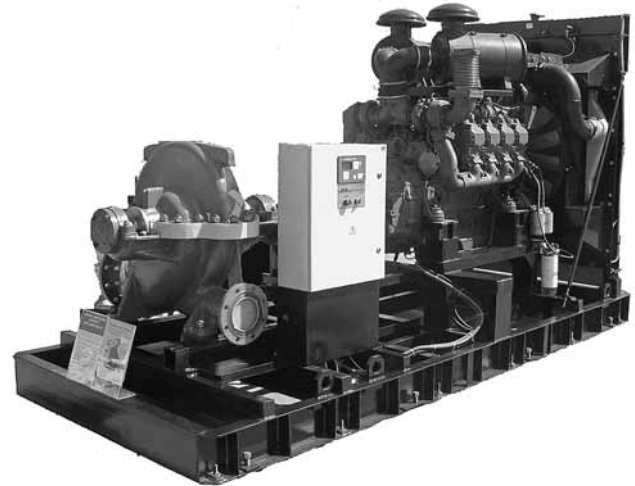

PERFORMANCE RANGE

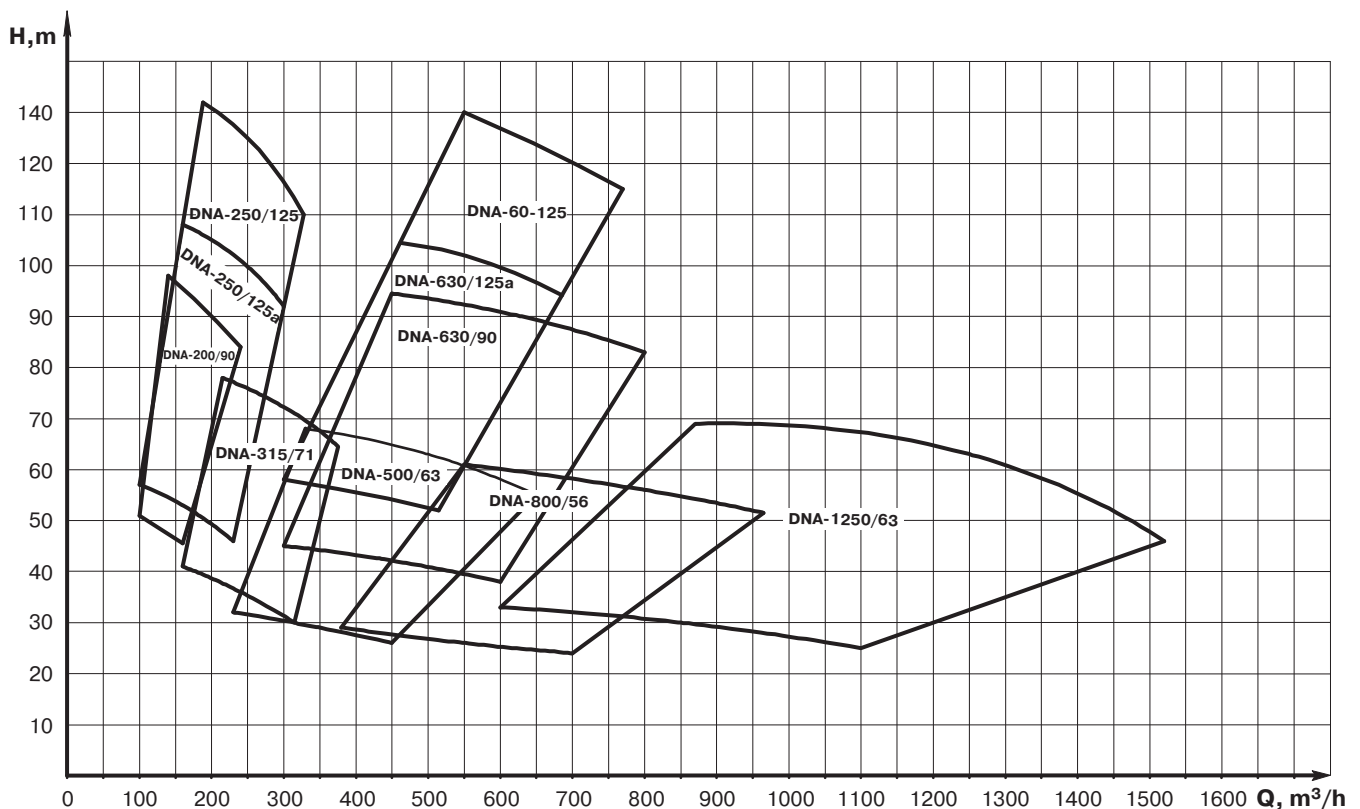

PUMP TYPE KEY

Example of designation:

DNA- 250/125a UHL 3.1 TU4734-306-05747979-2007

DNA - XXX/XXX UHL X

diesel driven pump unit

designation of associated pump

climatic version

location category

technical conditions - **TU4734-306-05747979-2007**

TECHNICAL PARAMETERS					
unit model	capacity. m ³ /h	head. m	positive suction head. m	associated motor	fuel flow rate. kg/h
DNA-200/60	200	60	6	D245	
DNA-200/90	140-240	98-82	5.5	YAMZ-236M2	17
DNA-200/90a	125-220	78-68	5.8		
DNA-250/125	165-320	132-114	6.0	YAMZ-238M2	25
DNA-250/125a	160-300	108-92	6.4	YAMZ-236M2	17
DNA-315/50	240-380	56-41	6.5		
DNA-315/71	220-375	78-65	6.5		
DNA-315/71a	210-360	68-57	7.0		
DNA-500/63	380-650	68-55	4.5	YAMZ-238B14	38
DNA-500/63a	330-600	58-45	4.8	YAMZ-238M2	25
DNA-500/63b	300-550	48-35	5.0		
DNA-630/90	450-800	94-83	5.5	YAMZ-7511.10	46.8
DNA-630/90a	370-720	78-68	5.8	YAMZ-238B14	38
DNA-630/90b	300-670	63-56	5.9		
DNA-630/125a	425-720	106-94	5.6	TMZ-84352.10	63
DNA-800/56	550-970	62-52	5.0	YAMZ-238B14	38
DNA-800/56a	520-880	52-43	5.1		
DNA-800/56b	500-820	44-37	5.2	YAMZ-236M2	17
DNA-1250/63	940-1550	69-56	6.0	TMZ-84352.10	63
DNA-1250/63a	730-1400	58-46	6.1	YAMZ-7511.10	46.8
DNA-1250/63b	600-1300	49-39	6.2	YAMZ-238B14	38
DNA-1600/90b	920-1600	59-57	7.2	TMZ-84352.10	63

OVERALL DIMENSIONS

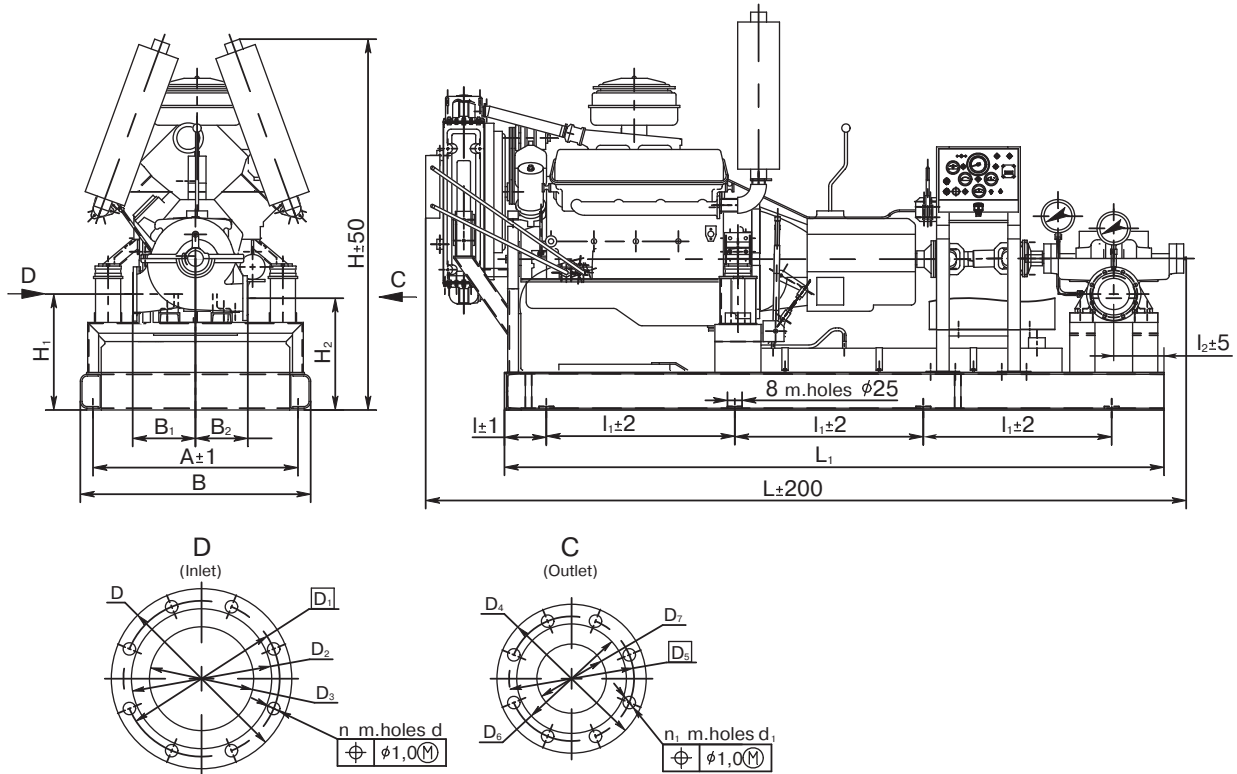

unit model	dimensions in mm												weight, kg								
	A	B	B ₁	B ₂	L	L ₁	I	I ₁	I ₂	H	H ₁	H ₂									
DNA-200/90	1080	1310	280	250	3250	3150	225	900	370	1830	545	545	2240								
DNA-200/90a					3470								2240								
DNA-250/125			3260	2300																	
DNA-250/125a			300	300	3255								525	2200							
DNA-315/50					3150								580	580	2250						
DNA-315/71			420	350	3430								370	2050	645	585	2250				
DNA-315/71a					3390									2420							
DNA-500/63			500	500	3620								370	2120	650	590	3110				
DNA-500/63a					3440									2522							
DNA-500/63b			1400	1380	400								3750	3560	205	1050	355	2060	645	575	3400
DNA-630/90													3790					2130			555
DNA-630/90a			1310	480	400								3440	3150	225	900	370	2050	655	595	2558
DNA-630/90b													3400					1980			2520
DNA-800/56			1380	500	450								3810	3560	205	1050	370	2130	685	585	3142
DNA-800/56a													3640					2120			615
DNA-800/56b			1310	600	600								3460	3150	225	900	370	2100	690	610	2815
DNA-1250/63													4020					2130			585
DNA-1250/63a			1400	1380	600								4070	3750	225	1100	410	2170	690	610	3517
DNA-1250/63b													4070					2170			610
DNA-1250/125b			1380	600	600								4070	3750	225	1100	410	2170	690	610	3517
DNA-1600/90b	4070	2170				610	3517														

unit model	dimensions in mm													
	D	D ₁	D ₂	D ₃	D ₄	D ₅	D ₆	D ₇	d	d ₁	n	n ₁		
DNA-200/90	260	225	202	150	215	180	158	100	18	18	8	8		
DNA-200/90a														
DNA-250/125														
DNA-250/125a	315	280	258	200	280	240	212	150			18	8	8	
DNA-315/50														
DNA-315/71														
DNA-315/71a	370	335	312	250	280	240	212	200			22	12	8	8
DNA-500/63														
DNA-500/63a														
DNA-500/63b					335	295	268	200					150	200
DNA-630/90														
DNA-630/90a														
DNA-630/90b	280	240	212	150	200	150	12	8						
DNA-630/125														
DNA-630/125a									435	395	365	300	335	295
DNA-800/56														
DNA-800/56a														
DNA-800/56b	485	445	415	350	390	350	320	250	22	26	12	12		
DNA-1250/63														
DNA-1250/63a														
DNA-1250/63b					335	295	268	200					300	12
DNA-1250/125b														
DNA-1600/90b														

CONFIGURATION

Standard configuration:

- diesel drive on the basis of a diesel motor;
- centrifugal two-side inlet pump of D type (own production);
- foundation frame;
- drive shaft with protective cover;
- manual start, stop and control system with warning protection system and motor protection;
- weather protection hood (version with a hood).

Configuration for melioration:

- skids for unit displacement by tracking or chassis;

- suction line with lifting mechanism (hand winch);
- gas-jet vacuum device for suction line filling;
- shutter on the pressure tube.

Configuration for fire-extinguishing stations and main pump reservation (automatic start):

- manual start, stop and control system with warning protection system and motor protection on the basis of a microprocessor controller ComAP;
- cooling liquid electric heater 220V or 380V main supply for maintenance of motor in hot standby mode;
- accumulator battery automatic charge system.

Auxiliary equipment			
	name		name
1	liquid prestart heater PDZH-30	5	weather protection hood
2	liquid prestart heater PDZH-600I for YAMZ-8502	6	extra fuel tanks for 1000 L, 1500 L or 2000 L
3	emergency stop air choke	7	trailer with PSM or PTS for general road travel
4	spark guard		

SUBMERSIBLE ELECTRIC PUMP UNITS OF 2ECV TYPE WITH LEAK PROOF MOTORS OF DAP SERIES

DAP — asynchronous submersible motor.

New electric motor design makes it possible to increase the unit operation life, enhance efficiency, and maintain it within the entire period of operation, which results in power consumption.

APPLICATION

Leak proof electric motors of **DAP** series are intended for use as a part of centrifugal well electric pump units of **2ECV** type.

Advantages of DAP series electric motors:

- electric motor life till overhaul is 25000 hours;
- electric motor inner chamber is insulated against pumped water, which prevents sand ingress in the bearings and corrosion of electrotechnical steel, resulting in increase of the electric motor operation life;
- high efficiency within the entire period of operation.

Design features:

- electric motor inner chamber is insulated by means of an end seal unit;
- electric motor inner chamber is filled with a mixture approved for contact with drinking water having antifreeze properties, which makes it possible to store and transport the pump units at the temperature down to -30°C ;
- axial and radial bearings are made of modern polymer materials;
- return thrust bearing is intended for prevention of rotor axial displacement at «floating-up» of impellers;



- a «breathing» unit is provided for compensation of liquid thermal expansion inside the electric motor;
- a sand baffle is used for protection of the end seal against sand;
- all electric motors are pre-filled with liquid at the manufacturer plant, passed complete testing and supplied ready for use to consumers;
- **2ECV** pumps guarantee is 2 years.

Design of asynchronous immersed motor (DAP)

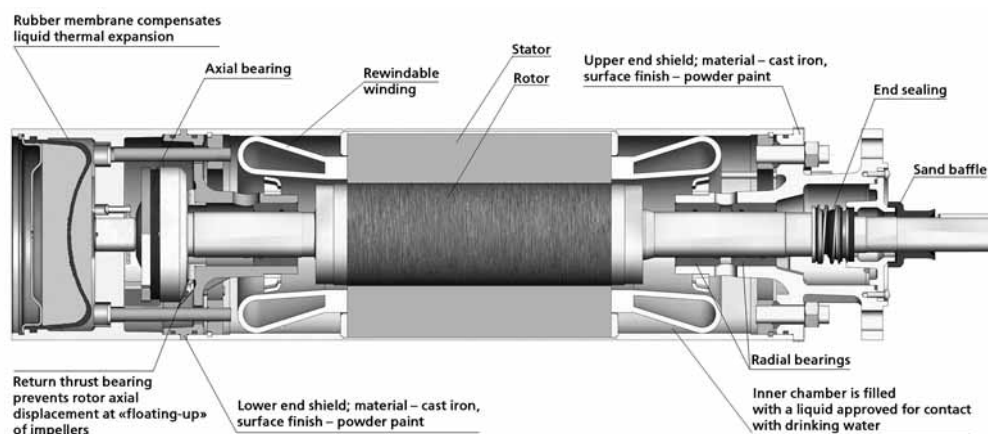

MOTOR TYPE KEY

Example of designation of immersed leak proof electric motors:

DAP 10-130

D – motor
A – asynchronous
P – immersed

motor characteristics by diameter of well decreased by 25 times and rounded:

6 – for a well with the inner diameter of well casing equal to 150 mm

8 – for a well with the inner diameter of well casing equal to 200 mm

10 – for a well with the inner diameter of well casing equal to 250 mm

12 – for a well with the inner diameter of well casing equal to 300 mm

nominal power, kW

DAP XX - XXX

The reference designation structure of electric pump units 2ECV is fully equivalent to the reference designation structure of electric pump units ECV

TECHNICAL PARAMETERS OF ELECTRIC PUMP UNITS WITH MOTORS OF DAP SERIES							
unit model	electric motor			unit model	electric motor		
	model	power, kW	eff., %		model	power, kW	eff., %
2ECV6-4-70, 100	DAP6-3	3	77	2ECV6-10-290, 350	DAP6-13	13	79
2ECV6-6.5-60, 85				2ECV6-16-160, 190			
2ECV6-10-50				2ECV8-16-160,180			
2ECV6-4-160, 190	DAP6-4	4	78	2ECV8-25-125	DAP6-15	15	82
2ECV6-6.5-105, 125				prospective pump			
2ECV6-10-80				prospective pump			
2ECV6-16-50	DAP6-5.5	5.5	79	2ECV6-18.5	DAP6-18.5	18.5	82
2ECV6-6.5-140, 160				2ECV8-25-100			
2ECV6-10-110, 120				2ECV8-40-60			
2ECV6-25-50	DAP6-7.5	7.5	80	2ECV8-25-125	DAP8-11	11	82
2ECV6-6.5-185, 225				2ECV8-16-140,160			
2ECV6-10-160, 185				2ECV8-16-180,200			
2ECV6-16-110	DAP6-7.5	7.5	80	2ECV8-25-150	DAP8-13	13	82
2ECV6-25-60,70, 80				2ECV8-40-90			
2ECV8-16-100				2ECV8-65-40			
2ECV8-25-55, 70	DAP6-7.5	7.5	80	2ECV8-16-260	DAP8-15	15	83
2ECV8-40-40				2ECV8-25-180			
2ECV6-10-185				2ECV8-65-40			
2ECV6-16-140	DAP6-9	9	81	2ECV8-25-230	DAP8-18.5	18.5	83
2ECV6-25-90				2ECV8-40-120			
2ECV6-10-235				2ECV8-65-70			
2ECV6-16-140	DAP6-11	11	81	2ECV10-65-65	DAP8-22	22	84
2ECV6-25-100,120				2ECV10-120-40			
2ECV8-16-140				2ECV10-65-90			
2ECV8-25-100	DAP6-11	11	81	2ECV10-120-40	DAP8-26	26	84
2ECV8-40-60				2ECV10-65-90			

TECHNICAL PARAMETERS OF ELECTRIC PUMP UNITS WITH MOTORS OF DAP SERIES			
unit model	electric motor		
	model	power, kW	efficiency, %
2ECV8-25-300	DAP8-30	30	85
2ECV8-40-150			
2ECV8-65-90, 110			
2ECV10-65-110,125			
2ECV10-120-60, 80			
2ECV10-160-50			
2ECV8-40-180, 200	DAP8-37	37	85
2ECV8-65-110, 145			
2ECV8-25-340, 400			
2ECV8-40-200	DAP8-45	45	86
2ECV8-65-180			
2ECV10-65-110			
2ECV10-120-60	DAP10-30	30	85
2ECV10-160-25,35			
2ECV12-210-25			
2ECV10-65-125			
2ECV12-250-35	DAP10-37	37	86
2ECV10-65-150, 175			
2ECV10-120-100	DAP10-45	45	86
2ECV10-160-75			
2ECV12-160-65			
2ECV12-210-55			
2ECV10-65-200, 225			
2ECV10-100-120			
2ECV10-120-120	DAP10-55	55	87
2ECV10-65-250			
2ECV10-160-100			
2ECV12-160-100			
2ECV12-200-70	DAP10-65	65	87
2ECV10-65-275			
2ECV10-120-140, 160			
2ECV10-160-125			
2ECV12-200-70			
2ECV12-250-70			
2ECV10-160-150	DAP10-75	75	88
2ECV12-160-140			
2ECV12-200-105			
2ECV12-160-175			
2ECV12-250-105	DAP10-110	110	88
2ECV12-160-200			
2ECV12-250-140			
2ECV12-160-200	DAP10-130	130	88
2ECV12-250-140			

CENTRIFUGAL SUBMERSIBLE ELECTRIC PUMP UNITS OF ECV TYPE

APPLICATION

Electric pump units of **ECV** type are intended for lifting of drinking water from artesian wells for the purpose of municipal, industrial and agricultural water supply, irrigation, well drainage and other similar works.

Pumped liquid is water with the total mineral content (dry residue) not more than 1500 mg/l, with the hydrogen index (pH) from 6.5 to 9.5, temperature up to 25°C, weight ratio of solid mechanical impurities not more than 0.01%, with chloride content not more than 350 mg/l, sulfates – not more than 500 mg/l, hydrogen sulfide – not more than 1.5 mg/l.

Design features:

The unit consists of an asynchronous electric motor and a multi-section centrifugal pump unit interconnected by a rigid coupling. The rotors of electric motor and pump are equipped with rubber-metal bearings. In the bottom of the electric motor there is a thrust bearing receiving axial load. At the entry to the pump unit there is a protective filter screen protecting the pump from ingress of big mechanical fragments. The electric motor is water-filled, with short-circuited rotor and synchronous speed of 3000 rpm. The rotor «squirrel cage» is made of copper. The stator winding is made of water resistant wire.

The electric motor is cooled with pumped water.

PUMP TYPE KEY

Examples of designation:

ECV 6-10-80 \ ECV 8-40-90 \ ECV 10-120-100

electric unit type

motor characteristics by diameter of well decreased by 25 times and rounded:

6 – for a well with the inner diameter of well casing equal to 150 mm

8 – for a well with the inner diameter of well casing equal to 200 mm

10 – for a well with the inner diameter of well casing equal to 250 mm

12 – for a well with the inner diameter of well casing equal to 300 mm

nominal capacity, m³/h

nominal head, m



ECV XX - XXX - XXX

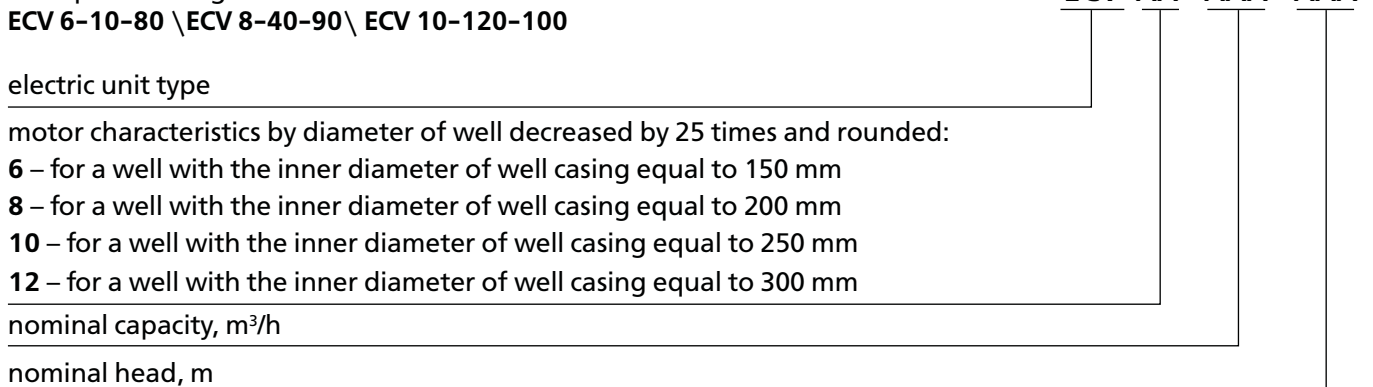

TECHNICAL PARAMETERS

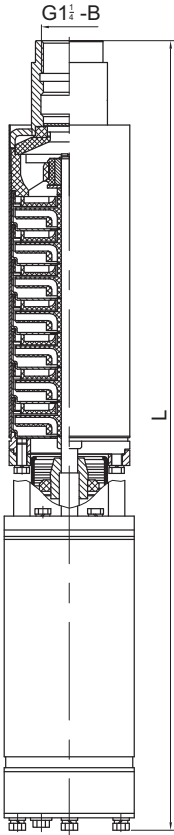

unit model	capacity m ³ /h	rated parameters			L, mm	weight, kg
		head, m	current, A	power, kW		
ECV4-2.5-65	2,5	65	3.8	1.1	775	19.5
ECV4-2.5-80		80	4.2	1.1	855	20
ECV4-2.5-100		100	5.8	1.5	1050	25.9
ECV4-2.5-120		120	6.2	2.2	1130	26.5
ECV4-2.5-140		140	6.5	2.2	1260	29
ECV4-2.5-160		160	9.5	3	1410	32
ECV4-2.5-200		200	9.5	3	1600	35

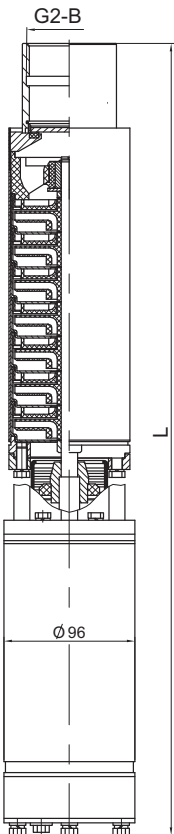

unit model	capacity m ³ /h	rated parameters			L, mm	weight, kg
		head, m	current, A	power, kW		
ECV4-6.5-70	6.5	70	8	2.2	1265	28.5
ECV4-6.5-85		85	11	3	1480	32.5
ECV4-6.5-115		115	12	4	1700	38.5
ECV4-6.5-130		130	14.5	5.5	1980	42
ECV4-6.5-150		150	16	5.5	2130	44
ECV4-10-25	10	25	4.5	1.1	760	20
ECV4-10-40		40	9.5	3	1175	29
ECV4-10-55		55	9.8	3	1315	31
ECV4-10-70		70	10	4	1530	35
ECV4-10-85		85	13	5.5	1760	41
ECV4-10-95		95	15	5.5	1980	42
ECV4-10-110		110	16	5.5	2130	44

TECHNICAL PARAMETERS

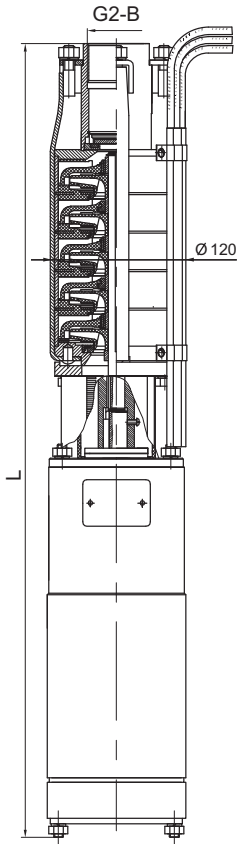

unit model	capacity m ³ /h	rated parameters			L, mm	weight, kg
		head, m	current, A	power, kW		
ECV5-4-75	4	75	6.5	2.2	1200	42
ECV5-4-100		100	9	3	1400	48
ECV5-4-125		125	11	3	1540	52
ECV5-4-160		160	12	4	1930	66
ECV5-6.5-50	6.5	50	6	2.2	1100	40
ECV5-6.5-65		65	6	2.2	1220	42
ECV5-6.5-80		80	10	3	1380	49
ECV5-6.5-100		100	11	3	1560	52
ECV4-6.5-120		120	12	4	1860	67
ECV5-6.5-140		140	12	4	2010	67

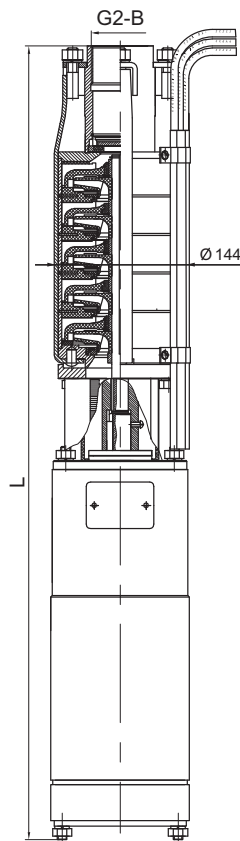

unit model	capacity m ³ /h	rated parameters			L, mm	weight, kg
		head, m	current, A	power, kW		
ECV6-4-70	4	70	4.6	2.2	1030	55
ECV6-4-100		100	6	3	1180	55
ECV6-4-130		130	8	4	1300	64
ECV6-4-160		160	9	4	1360	68
ECV6-4-190		190	10	4	1450	69
ECV6-6.5-60	6.5	60	5.5	2.2	1045	56
ECV6-6.5-85		85	8	3	1240	66
ECV6-6.5-105		105	9	4	1230	62
ECV6-6.5-125		125	10	4	1370	68
ECV6-6.5-140		140	11	5.5	1410	72
ECV6-6.5-160		160	12.5	6.3	1465	74
ECV6-6.5-185	10	185	14	7.5	1650	83
ECV6-6.5-225		225	18	7.5	1780	87
ECV6-10-50		50	5.8	2.2	1015	55
ECV6-10-80		80	8	4	1200	66
ECV6-10-110		110	12	5.5	1320	68
ECV6-10-120		120	13	5.5	1360	69
ECV6-10-140		140	13.5	6.3	1470	72
ECV6-10-160		160	17.5	7.5	1545	79
ECV6-10-185		185	18.5	8	1750	89
ECV6-10-235		235	24	11	1960	94
ECV6-10-290	290	31	13	2200	110	
ECV6-10-350	350	35	13	2480	121	

TECHNICAL PARAMETERS

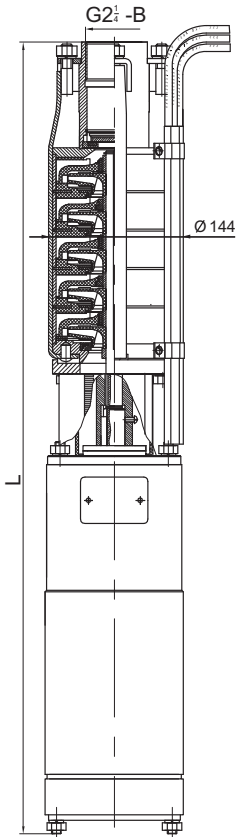

unit model	capacity m ³ /h	rated parameters			L, mm	weight, kg
		head, m	current, A	power, kW		
ECV6-16-50	16	50	10	3	1160	60
ECV6-16-75		75	16	5.5	1355	70
ECV6-16-90		90	15	6.3	1430	72
ECV6-16-100		100	16.5	6.3	1480	74
ECV6-16-110		110	20	7.5	1615	80
ECV6-16-140		140	26	11	1850	91
ECV6-16-160		160	30	13	2000	103
ECV6-16-190		190	34	13	2200	110

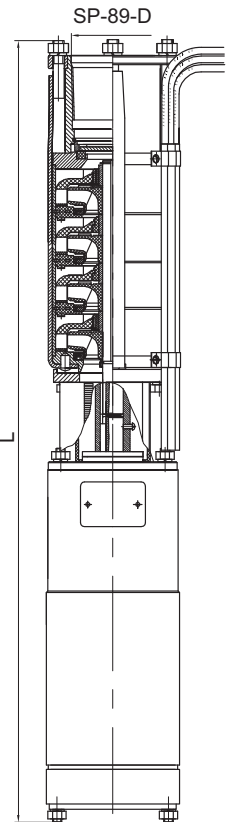

unit model	capacity m ³ /h	rated parameters			L, mm	weight, kg
		head, m	current, A	power, kW		
ECV6-25-50	25	50	12	5.5	1210	65
ECV6-25-60		60	14.8	6.3	1340	70
ECV6-25-70		70	16	7.5	1430	74
ECV6-25-80		80	18	7.5	1480	77
ECV6-25-90		90	18.8	9	1615	87
ECV6-25-100		100	23	11	1720	90
ECV6-25-120		120	26	11	1820	92

TECHNICAL PARAMETERS

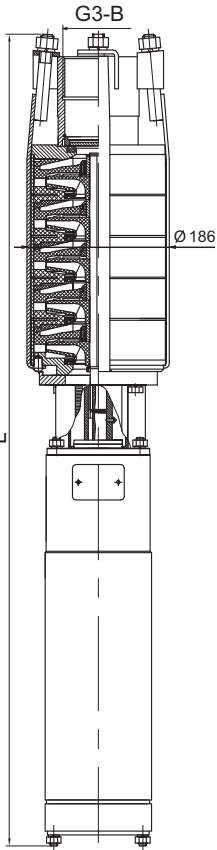

unit model	capacity m ³ /h	rated parameters			L, mm	weight, kg
		head, m	current, A	power, kW		
ECV8-16-100	16	100	16	6,3	1220	74
ECV8-16-140		140	25	11	1440	93
ECV8-16-160		160	30	13	1590	107
ECV8-16-180		180	32	13	1650	110
ECV8-16-200		200	36	17	1620	135
ECV8-16-260		260	45	22	1710	142
ECV8-25-55	25	55	15	5.5	1100	67
ECV8-25-70		70	18	8.5	1220	76
ECV8-25-100		100	27	11	1410	90
ECV8-25-125		125	33	13	1570	102
ECV8-25-150		150	37	17	1545	128
ECV8-25-180		180	49	18.5	1660	132
ECV8-25-230		230	60	22	1840	142
ECV8-25-300		300	76	32	2318	212
ECV8-25-340		340	80	45	2570	225
ECV8-25-400		400	90	45	2570	234
ECV8-40-40	40	40	18	6.3	1140	71
ECV8-40-60		60	25	11	1310	87
ECV8-40-90		90	36	17	1440	127
ECV8-40-120		120	48	22	1490	135
ECV8-40-150		150	56	27	1790	170
ECV8-40-180		180	63	32	1920	172
ECV8-40-200	200	72	45	2180	200	

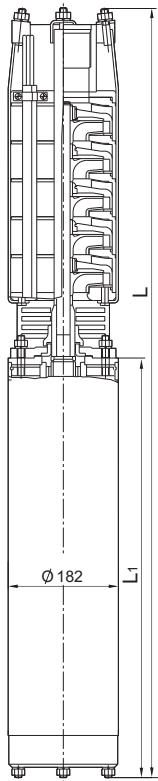

unit model	capacity m ³ /h	rated parameters			L1, mm	L, mm	weight, kg
		head, m	cur- rent, A	power, kW			
ECV8-16-140	16	140	24	11	635	1290	106
ECV8-16-160		160	24	11	635	1340	110
ECV8-16-180		180	35	16	685	1440	124
ECV8-16-200		200	35	16	685	1490	128
ECV8-25-55	25	55	14	5.5	565	1035	70
ECV8-25-70		70	16.5	7.5	585	1115	79
ECV8-25-90		90	20	9	605	1190	88
ECV8-25-100		100	24	11	635	1220	100
ECV8-25-125		125	30	13	635	1330	115
ECV8-25-150		150	35	16	685	1435	123
ECV8-25-180		180	46	22	745	1700	152
ECV8-25-230		230	54	25	785	1900	170
ECV8-25-300		300	66	32	855	2150	190
ECV8-40-35		40	35	14	5.5	565	1000
ECV8-40-60	60		24	11	635	1150	98
ECV8-40-70	70		24	11	635	1150	98
ECV8-40-90	90		33	15	685	1260	110
ECV8-40-110	110		37	17	745	1380	121
ECV8-40-125	125		46	20	745	1440	125
ECV8-40-145	145		54	25	785	1550	133
ECV8-40-150	150		54	25	785	1640	140
ECV8-40-160	160		54	25	785	1640	140
ECV8-40-180	180		63	30	855	1740	150

TECHNICAL PARAMETERS

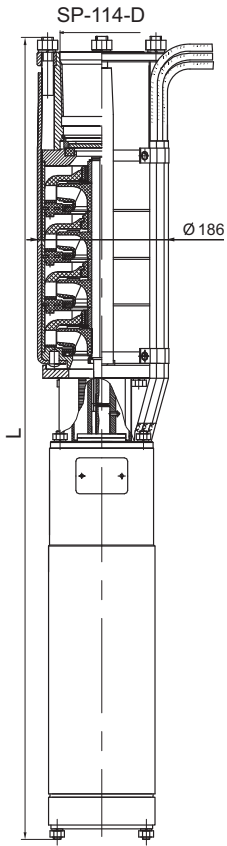

unit model	capacity m ³ /h	rated parameters			L, mm	weight, kg
		head, m	current, A	power, kW		
ECV8-65-40	65	40	38	17	1400	131
ECV8-65-70		70	49	22	1735	115
ECV8-65-90		90	65	27	2090	198
ECV8-65-110		110	70	33	2165	201
ECV8-65-145		145	100	45	2500	232
ECV8-65-180		180	108	45	2660	240

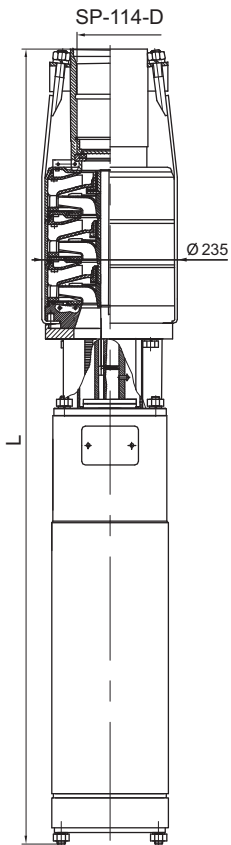

unit model	capacity m ³ /h	rated parameters			L, mm	weight, kg
		head, m	current, A	power, kW		
ECV10-65-65	65	65	45	22	1350	142
ECV10-65-90		90	40	27	1530	210
ECV10-65-110		110	65	32	1640	220
ECV10-65-125		125	71	33	1640	220
ECV10-65-150		150	77	45	1840	257
ECV10-65-175		175	93	45	1920	265
ECV10-65-200		200	106	50	2000	285
ECV10-65-225		225	125	65	2095	290
ECV10-65-250		250	135	65	2170	300
ECV10-65-275		275	155	75	2320	320

TECHNICAL PARAMETERS

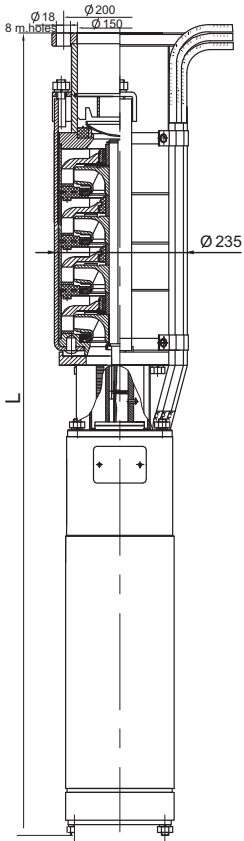

unit model	capacity m ³ /h	rated parameters			L, mm	weight, kg
		head, m	current, A	power, kW		
ECV10-100-120	100	120	115	55	2200	295
ECV10-120-40	120	40	46	22	1320	142
ECV10-120-60		60	60	32	1570	217
ECV10-120-80		80	85	33	1700	222
ECV10-120-100		100	95	45	1930	254
ECV10-120-120		120	115	55	2085	296
ECV10-120-140		140	141	75	2280	315
ECV10-120-160		160	154	75	2355	326

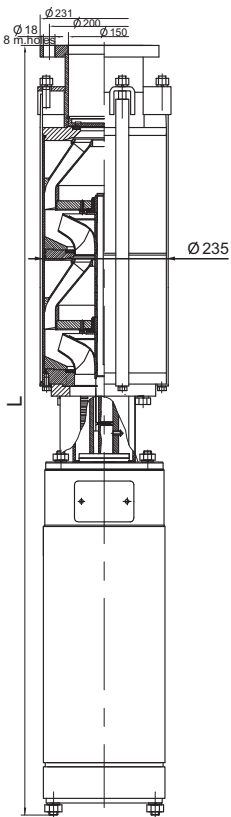

unit model	capacity m ³ /h	rated parameters			L, mm	weight, kg
		head, m	current, A	power, kW		
ECV10-160-25	160	25	36	17	1315	183
ECV10-160-35		35	47	22	1485	204
ECV10-160-50		50	67	32	1615	236
ECV10-160-75		75	98	45	1920	270
ECV10-160-100		100	130	65	2180	310
ECV10-160-125		125	165	80	2420	340
ECV10-160-150		150	185	90	2590	351

TECHNICAL PARAMETERS

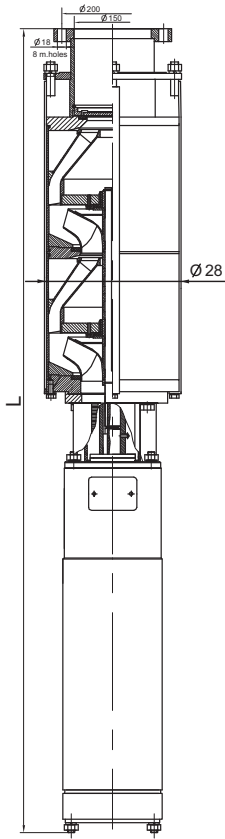

unit model	capacity m ³ /h	rated parameters			L, mm	weight, kg
		head, m	current, A	power, kW		
ECV12-160-65	160	65	93	45	1620	255
ECV12-160-100		100	130	65	1800	286
ECV12-160-140		140	165	90	1970	327
ECV12-160-175		175	225	110	2025	402
ECV12-160-200		200	278	130	2360	477
ECV12-200-35	200	35	69	32	1550	235
ECV12-200-70		70	133	65	2010	313
ECV12-200-105		105	190	90	2390	358
ECV12-200-140		140	270	110	2610	440
ECV12-210-25	210	25	55	22	1260	175
ECV12-210-55		55	98	45	1640	250
ECV12-250-35	250	35	75	37	1680	267
ECV12-250-70		70	146	75	2090	350
ECV12-250-105		105	235	110	2360	410
ECV12-250-140		140	270	130	2840	504

TECHNICAL PARAMETERS							
unit model	unit			motor			
	capacity, m ³ /h	head, m	eff-cy, %	model	power, kW	cur., A	eff., %
ECV 4-1.5-35	1,5	35	29	Franklin 4"-0.37*	0.37	3.0	53
			36	Franklin 4"-0.37		1.1	66
50		30	Franklin 4"-0.37*	3.0		53	
		36	Franklin 4"-0.37	1.1		66	
ECV 4-1.5-65		65	35	Franklin 4"-0.55*	0.55	4.1	63
			37	Franklin 4-0.55"		1.6	67
ECV 4-1.5-80		80	32	Franklin 4"-0.55*		4.1	63
			34	Franklin 4-0.55"		1.6	67
ECV 4-1.5-100		100	31	Franklin 4"-0.75*	0.75	5.4	60
			35	Franklin 4"-0.75		2.1	69
ECV 4-1.5-120		120	34	Franklin 4"-1.1*	1.1	8.0	62
			40	Franklin 4-1.1"		3.0	73
ECV 4-1.5-140		140	32	Franklin 4"-1.1*		8.0	62
			32	DAPV 1.1-96		3.0	61.9
ECV 4-2.5-35	2,5	35	34	Franklin 4"-0.37*	0.37	4.1	63
			42	Franklin 4-0.37"		1.6	67
50		34	Franklin 4"-0.55*	0.55	4.9	53.8	
		38	Franklin 4"-0.55		2	57.5	
ECV 4-2.5-65		65	36	Franklin 4"-0.75*	0.75	5.4	60
			42	Franklin 4"-0.75		2.1	69
ECV 4-2.5-80		80	38	Franklin 4"-1.1*	1.1	8.0	62
			44	Franklin 4"-1.1		3.0	73
ECV 4-2.5-100		100	38	Franklin 4"-1.1*		8.0	62
			36	DAPV 1.1-96		3.0	61.9
ECV 4-2.5-120		120	38	Franklin 4"-1.5*	1.5	10.3	66
			42	Franklin 4"-1.5		4.0	73
ECV 4-2.5-140		140	38	Franklin 4"-1.5*		10.3	66
			42	Franklin 4"-1.5		4.0	73
ECV 5-4-125	4	125	35	DAPV 3-120	3	7.6	74
ECV 5-4-135		135	36			8	
ECV 5-4-160		160	37	DAPV 4-120	4	8.5	74
ECV 5-4-180		180	37			9.3	
ECV 5-4-200		200	38	DAPV 5.5-120	5.5	12.8	75
ECV 5-4-220		220	38				
ECV 5-6.5-80	6,5	80	39	DAPV 3-120	3	7.6	74
ECV 5-6.5-95		95	39			8	
ECV 5-6.5-120		120	40	DAPV 4-120	4	9.3	74
ECV 5-6.5-145		145	41	DAPV 5.5-120	5.5	12.8	75
ECV 5-6.5-170		170	42				
ECV 5-6.5-200		200	42	DAPV 6.3-120	6.3	14.8	75
ECV 5-10-50	10	50	40	DAPV 3-120	2.2	5.2	74
ECV 5-10-65		65	41		3	7.6	75
ECV 5-10-80		80	41	DAPV 4-120	4	9.3	75
ECV 5-10-95		95	41	DAPV 5.5-120	5.5	12.8	76
ECV 5-10-125		125	41	DAPV 6.3-120	6.3	14.8	76
ECV 5-10-140		140	41	DAPV 7.5-120	7.5	17.2	76.5

* Pumping unit with single-phase motor is completed with startup protection device to provide motor operation in 230 V single-phase network.

TECHNICAL PARAMETERS							
unit model	unit			motor			
	capacity, m ³ /h	head, m	eff-cy, %	model	power, kW	cur., A	eff., %
ECV 6-6.5-60	6,5	60	44	PEDV 2.2-144	2.2	6.5	76
ECV 6-6.5-75		75	44	PEDV 3-144	3	7	77
ECV 6-6.5-90		90	47				
ECV 6-6.5-105		105	46	PEDV 4-144	4	8.5	78
ECV 6-6.5-120		120	48				
ECV 6-6.5-140		140	47				
ECV 6-6.5-160		160	47	PEDV 5.5-144	5.5	12	79
ECV 6-6.5-180		180	47				
ECV 6-6.5-200		200	47	PEDV 6.3-144	6.3	14.5	79
ECV 6-6.5-225		225	47	PEDV 7.5-144	7.5	16.5	80
ECV 6-6.5-250		250	47				
ECV 6-6.5-275		275	47	PEDV 9-144	9	20	80
ECV 6-6.5-300		300	47	PEDV 11-144	11	24	81
ECV 6-6.5-325		325	47				
ECV 6-10-50		10	50	48	PEDV 2.2-144	2.2	6.5
ECV 6-10-60	60		48	PEDV 3-144	3	7	77
ECV 6-10-70	70		48				
ECV 6-10-80	80		52	PEDV 4-144	4	8.5	78
ECV 6-10-90	90		52				
ECV 6-10-110	110		53				
ECV 6-10-120	120		53	PEDV 5.5-144	5.5	12	79
ECV 6-10-140	140		53				
ECV 6-10-160	160		53	PEDV 7.5-144	7.5	16.5	80
ECV 6-10-180	180		54				
ECV 6-10-200	200		54	PEDV 9-144	9	20	80
ECV 6-10-230	230	54	PEDV 11-144	11	24	81	
ECV 6-10-260	260	54					
ECV 6-16-50	16	50	48	PEDV 4-144	4	8.5	77
ECV 6-16-60		60	48	PEDV 4-144	4	8.5	78
ECV 6-16-70		70	53	PEDV 5.5-144	5.5	12	79
ECV 6-16-80		80	53				
ECV 6-16-90		90	53				
ECV 6-16-110		110	53	PEDV 7.5-144	7.5	16.5	80
ECV 6-16-130		130	53	PEDV 9-144	9	20	80
ECV 6-16-140		140	51	PEDV 11-144	11	24	81
ECV 6-16-160		160	51				
ECV 6-25-50	25	50	49	PEDV 5.5-144	5.5	12	79
ECV 6-25-60		60	49	PEDV 6.3-144	6.3	14.5	79
ECV 6-25-70		70	50	PEDV 7.5-144	7.5	16.5	80
ECV 6-25-80		80	50				
ECV 6-25-90		90	51	PEDV 11-144	11	24	80
ECV 6-25-100		100	51	PEDV 11-144	11	24	81

TECHNICAL PARAMETERS

unit model	unit			motor				
	capacity, m ³ /h	head, m	eff-cy, %	model	power, kW	cur., A	eff., %	
ECV 6-6.5-95	6.5	95	47	Franklin 6"-4	4	10.6	76	
ECV 6-6.5-105		105	46					
ECV 6-6.5-120		120	48					
ECV 6-6.5-140		140	47	Franklin 6"-5.5	5.5	13.3		
ECV 6-6.5-160		160						
ECV 6-6.5-180		180						
ECV 6-6.5-200		200						
ECV 6-6.5-225		225						
ECV 6-6.5-250		250						
ECV 6-6.5-275		275		Franklin 6"-9	9	21.4	78	
ECV 6-10-70		10	70	48	Franklin 6"-4	4	10.6	76
ECV 6-10-80			80	52				
ECV 6-10-90	90		53	Franklin 6"-5.5				
ECV 6-10-110	110							
ECV 6-10-120	120							
ECV 6-10-140	140		54	Franklin 6"-7.5	7.5	17.7	77	
ECV 6-10-160	160							
ECV 6-10-180	180							
ECV 6-10-200	200							
ECV 6-10-230	230			Franklin 6"-11	11	25.2	79	
ECV 6-16-60	16	60	48	Franklin 6"-4	4	10.6	76	
ECV 6-16-70		70	53	Franklin 6"-5.5	5.5	13.3		
ECV 6-16-80		80						
ECV 6-16-90		90						
ECV 6-16-110		110	51	Franklin 6"-7.5	7.5	17.7	77	
ECV 6-16-130		130		Franklin 6"-8	9	21.4	78	
ECV 6-16-140		140		Franklin 6"-11	11	25.2	79	
ECV 8-16-80		80		54	PEDV 5.5-144	5.5	12	79
ECV 8-16-100	100	PEDV 6.3-144	6.3		14.5			
ECV 8-16-120	120	PEDV 7.5-144	7.5		17.5	80		
ECV 8-16-140	140	PEDV 9-180	9		20	81		
ECV 8-16-160	160	PEDV 11-180	11		24			
ECV 8-16-180	180	56	PEDV 13-180		13	29.5	82	
ECV 8-16-200	200		PEDV 15-180		5	33	83	
ECV 8-16-220	220		PEDV 17-180		1	37	84	
ECV 8-16-260	260		PEDV 18.5-180		18.5	40	83	
ECV 8-16-280	280		PEDV 20-180		20	46.5	84	
ECV 8-16-300	300							
ECV 8-25-15	25	15	51	PEDV 2.2-144	2.2	6.5	76	
ECV 8-25-35		35		PEDV 4-144	4	8.5	78	
ECV 8-25-55		55		PEDV 5.5-144	5.5	12	79	
ECV 8-25-70		70	54	PEDV 7.5-144	7.5	17.5	80	
ECV 8-25-90		90		PEDV 9-180	9	20.5	81	
ECV 8-25-110		110	58	PEDV 11-180	11	24		
ECV 8-25-125		125		PEDV 13-180	13	29.5	82	
ECV 8-25-150		150		PEDV 15-180	15	32	83	

TECHNICAL PARAMETERS								
unit model	unit			motor				
	capacity, m ³ /h	head, m	eff-cy, %	model	power, kW	cur., A	eff., %	
ECV 8-25-160	25	160	59	PEDV 17-180	17	37	84	
ECV 8-25-180		180		PEDV 18.5-180	18.5	40	83	
ECV 8-25-200		200		PEDV 20-180	20	46.5	84	
ECV 8-25-230		230		PEDV 22-180	22	46.2		
ECV 8-25-250		250		PEDV 25-180	25	52.5	84.5	
ECV 8-25-270		270		PEDV 30-180	30	63	85	
ECV 8-25-300		300		PEDV 32-180	32	68	85	
ECV 8-40-15		40		15	51	PEDV 3-144	3	6.8
ECV 8-40-35	35		53	PEDV 5.5-144	5.5	12	79	
ECV 8-40-55	55		54	PEDV 9-180	9	20.5	81	
ECV 8-40-70	70		55	PEDV 11-180	11	24		
ECV 8-40-90	90		57	PEDV 15-180	15	33	83	
ECV 8-40-110	110		58	PEDV 17-180	17	37	84	
ECV 8-40-125	125			PEDV 20-180	20	46.5		
ECV 8-40-145	145			PEDV 25-180	25	52.5	84.5	
ECV 8-40-160	160			59	PEDV 30-180	30	63	85
ECV 8-40-180	180				PEDV 32-180	32	68	86
ECV 8-40-200	200			59	PEDV 32-180	32	68	86
ECV 8-65-20	65		20	52	PEDV 5.5-144	5.5	12	79
ECV 8-65-35			35	53	PEDV 9-180	9	20	81
ECV 8-65-55			55		PEDV 15-180	15	33	83
ECV 8-65-70			70		PEDV 18.5-180	18.5	40	
ECV 8-65-90			90	56	PEDV 25-180	25	52.5	84.5
ECV 8-65-110		110	58	PEDV 32-180	32	68	85	
ECV 8-65-125		125		58				
ECV 8-25-110		25	110	58	Franklin 6"-11	11	27.2	80
ECV 8-25-125	125		Franklin 6"-13		13	30.8	81	
ECV 8-25-150	150		Franklin 6"-15		15	35	82	
ECV 8-25-160	160		Franklin 6"-18.5	18.5	42			
ECV 8-25-180	180		59					
ECV 8-25-230	230			Franklin 6"-22	22	49.1	84	
ECV 8-40-70	40		70	55	Franklin 6"-11	11	27.2	80
ECV 8-40-90		90	57	Franklin 6"-15	15	35	82	
ECV 8-40-110		110	58	Franklin 6"-18.5	18.5	42		
ECV 8-40-125		125		Franklin 6"-22	22	49.1	84	
ECV 8-40-145		145		Franklin 6"-26	26	57.5		
ECV 8-40-160		160	58	Franklin 6"-30	30	66.4	84.4	
ECV 8-40-180		180		Franklin 8"-30		63		
ECV 8-65-55		65	55	53	Franklin 6"-15	15	35	82
ECV 8-65-70			70	Franklin 6"-18.5	18.5	42		
ECV 8-65-90	90		56	Franklin 6"-26	26	57.5	84	
ECV 8-65-110	110		56	Franklin 6"-30	30	66.4		84.4
ECV 8-65-110				Franklin 8"-30		63		
ECV 8-65-125	125		58	Franklin 8"-37	37	68	85	

TECHNICAL PARAMETERS

unit model	unit			motor			
	capacity, m ³ /h	head, m	eff-cy, %	model	power, kW	cur., A	eff., %
ECV 10-65-65	65	65	61	PEDV 18.5-180	18.5	40	83
				PEDV 18.5-235		41	
ECV 10-65-100		100	62	PEDV 25-180	25	52.5	84.5
				PEDV 25-235		54	
ECV 10-65-125		125	62	PEDV 32-180	32	68	85
				PEDV 33-235	33	71	
ECV 10-65-160		160	62	PEDV 37-235	37	82	86
ECV 10-65-200				PEDV 50-235	50	109	
ECV 10-65-225		225	62	PEDV 55-235	55	120	85
ECV 10-65-250		250		PEDV 63-235	63	139	
ECV 10-65-300		300	62	PEDV 75-235	75	165	85
ECV 10-65-325		325		PEDV 80-235	80	175	
ECV 10-120-40	120	40	59	PEDV 18.5-180	18.5	40	83
				PEDV 18.5-235		41	
ECV 10-120-60		60	63	PEDV 32-180	32	68	85
				PEDV 33-235	33	72	
ECV 10-120-80		80	63	PEDV 37-235	37	81	86
ECV 10-120-100		100		PEDV 45-235	45	99	
ECV 10-120-120		120	64	PEDV 55-235	55	121	85
ECV 10-120-140		140		PEDV 63-235	63	138	
ECV 10-120-160		160	64	PEDV 75-235	75	165	85
ECV 10-120-180		180		PEDV 80-235	80	176	
ECV 10-120-200		200	64	PEDV 90-235	90	199	86
ECV 10-65-65		65	65	59	Franklin 6"-18.5	18.5	42
ECV 10-65-100	100		60	Franklin 6"-26	26	56.7	83
ECV 10-65-160	160		61	Franklin 8"-37	37	76	84
ECV 10-65-200	200		62	Franklin 8"-55	55	110	86
ECV 10-120-60	120	60	63	Franklin 8"-30	30	60	87
ECV 10-120-80		80	63	Franklin 8"-37	37	76	
ECV 10-120-100		100	64	Franklin 8"-45	45	90	88
ECV 10-120-120		120	65	Franklin 8"-55	55	110	

OVERALL DIMENSIONS

unit model	motor model	A overall size, mm	B motor size, mm	weight, kg	
				unit	motor
ECV 4-1.5-35	Franklin 4"-0.37	482	242.1	11.4	8.3
	Franklin 4"-0.37	463	223.0	10.4	7.3
ECV 4-1.5-50	Franklin 4"-0.37	622	242.1	12.1	8.3
	Franklin 4"-0.37	603	223.0	11.1	7.3
ECV 4-1.5-65	Franklin 4"-0.55	710	270.8	14.1	9.6
	Franklin 4"-0.55	682	242.1	12.8	8.3

OVERALL DIMENSIONS

unit model	motor model	A overall size, mm	B motor size, mm	weight, kg	
				unit	motor
ECV 4-1.5-80	Franklin 4"-0.55	775	270.8	14.6	9.6
	Franklin 4"-0.55	747	242.1	13.3	8.3
ECV 4-1.5-100	Franklin 4"-0.75	883	298.5	16.3	10.8
	Franklin 4"-0.75	855	270.8	15.1	9.6
ECV 4-1.5-120	Franklin 4"-1.1	992	327.2	18.1	12.1
	Franklin 4"-1.1	963	298.5	16.8	10.8
ECV 4-1.5-140	Franklin 4"-1.1	1072	327.2	19.1	12.1
	Franklin 4"-1.1	1043	298.5	17.8	10.8
	DAPV 1.1-96	1300	410.0	21.8	14.4
ECV 4-2.5-35	Franklin 4"-0.37	482	242.1	11.4	8.3
	Franklin 4"-0.37	463	223.0	10.4	7.3
ECV 4-2.5-50	Franklin 4"-0.55	650	270.8	13.4	9.6
	Franklin 4"-0.55	622	242.1	12.1	8.3
ECV 4-2.5-65	Franklin 4"-0.75	738	298.5	15.3	10.8
	Franklin 4"-0.75	710	270.8	14.1	9.6
ECV 4-2.5-80	Franklin 4"-1.1	832	327.2	17.1	12.1
	Franklin 4"-1.1	803	298.5	15.8	10.8
ECV 4-2.5-100	Franklin 4"-1.1	912	327.2	17.6	12.1
	Franklin 4"-1.1	883	298.5	16.3	10.8
	DAPV 1.1-96	1055	410.0	19.9	14.4
ECV 4-2.5-120	Franklin 4"-1.5	1020	355.9	19.5	13.5
	Franklin 4"-1.5	992	327.2	18.1	12.1
ECV 4-2.5-140	Franklin 4"-1.5	1100	355.9	20.5	13.5
	Franklin 4"-1.5	1072	327.2	19.1	12.1
ECV 5-4-125	DAPV 3-120	1405	672	49	30
ECV 5-4-135		1440		52	
ECV 5-4-160	DAPV 4-120	1570		57	31
ECV 5-4-180		1720		60	
ECV 5-4-200	DAPV 5.5-120	1820		719	65
ECV 5-4-220		1930	70		
ECV 5-6.5-80	DAPV 3-120	1290	672	46	30
ECV 5-6.5-95		1355		47	
ECV 5-6.5-120	DAPV 4-120	1485		50	31
ECV 5-6.5-145	DAPV 5.5-120	1710	719	62	36
ECV 5-6.5-170		1850		66	
ECV 5-6.5-200	DAPV 6.3-120	2040		72	39
ECV 5-10-50	DAPV 3-120	1050	672	47	30
ECV 5-10-65		1220		48	
ECV 5-10-80	DAPV 4-120	1330		58.5	31
ECV 5-10-95	DAPV 5.5-120	1450	719	52.5	36
ECV 5-10-125	DAPV 6.3-120	1560		57	39
ECV 5-10-140	DAPV 7.5-120	1800	859	61	42
ECV 6-6.5-60	PEDV 2.2-144	1040	560	45	34
ECV 6-6.5-75	PEDV 3-144	1080		47	35
ECV 6-6.5-90		1120		48	
ECV 6-6.5-105	PEDV 4-144	1175	568	50	36
ECV 6-6.5-120		1230		51	

OVERALL DIMENSIONS

unit model	motor model	A overall size, mm	B motor size, mm	weight, kg	
				unit	motor
ECV 6-6.5-140	PEDV 5.5-144	1305	600	54	38
ECV 6-6.5-160		1380		55	
ECV 6-6.5-180		1455		57	
ECV 6-6.5-200	PEDV 6.3-144	1590	650	64	42
ECV 6-6.5-225	PEDV 7.5-144	1760	700	72	47
ECV 6-6.5-250		1955		75	
ECV 6-6.5-275	PEDV 9-144	2040	750	82	60
ECV 6-6.5-300	PEDV 11-144	2120		88	63
ECV 6-6.5-325		2230		90	
ECV 6-10-50	PEDV 2.2-144	930	560	44	34
ECV 6-10-60	PEDV 3-144	980		45	35
ECV 6-10-70		1030		46	
ECV 6-10-80	PEDV 4-144	1085	568	48	36
ECV 6-10-90		1138		49	
ECV 6-10-110	PEDV 5.5-144	1190	600	50	38
ECV 6-10-120		1270		54	
ECV 6-10-140	PEDV 6.3-144	1350	650	57	42
ECV 6-10-160	PEDV 7.5-144	1435	700	63	47
ECV 6-10-180		1515		65	
ECV 6-10-200	PEDV 9-144	1610	750	80	60
ECV 6-10-230	PEDV 11-144	1710		85	63
ECV 6-10-260		1810		87	
ECV 6-16-50	PEDV 4-144	1060	568	57	36
ECV 6-16-60		1170		60	
ECV 6-16-70	PEDV 5.5-144	1240	600	50	38
ECV 6-16-80		1280		51	
ECV 6-16-90		1315		53	
ECV 6-16-110	PEDV 7.5-144	1460	700	62	47
ECV 6-16-130	PEDV 9-144	1590	750	77	60
ECV 6-16-140	PEDV 11-144	1640		81	63
ECV 6-16-160		1715		84	
ECV 6-25-50	PEDV 5.5-144	1050	600	63	38
ECV 6-25-60	PEDV 6.3-144	1130	650	69	42
ECV 6-25-70	PEDV 7.5-144	1200	700	74	47
ECV 6-25-80		1240		75	
ECV 6-25-90	PEDV 11-144	1300	750	80	63
ECV 6-25-100		1450		85	
ECV 8-40-180	PEDV 32-180	2045	1025	149	108
ECV 8-40-200		2110		154	110
ECV 8-65-20	PEDV 5.5-144	1080	600	69	38
ECV 8-65-35	PEDV 9-144	1350	750	96	63
	PEDV 9-180	1300	700	95	62
ECV 8-65-55	PEDV 15-180	1375	755	104	69
ECV 8-65-70	PEDV 18.5-180	1510		128	91
ECV 8-65-90	PEDV 25-180	1580		145	105
ECV 8-65-110	PEDV 32-180	185	1010	152	110
ECV 8-65-125		1935		155	
ECV 8-25-110	Franklin 6"-11	1422	739	82	56
ECV 8-25-125	Franklin 6"-13	1532	829	88	61

OVERALL DIMENSIONS

unit model	motor model	A overall size, mm	B motor size, mm	weight, kg	
				unit	motor
ECV 8-25-150	Franklin 6"-15	1702	874	94	66
ECV 8-25-160	Franklin 6"-18.5	1807	919	99	70
ECV 8-25-180		1907		101	
ECV 8-25-230	Franklin 6"-22	2072	1009	114	79
ECV 8-40-70	Franklin 6"-11	1372	779	78	56
ECV 8-40-90	Franklin 6"-15	1562	874	92	66
ECV 8-40-110	Franklin 6"-18.5	1667	919	100	70
ECV 8-40-125	Franklin 6"-22	1817	1009	113	79
ECV 8-40-145	Franklin 6"-26	1922	1114	127	90
ECV 8-40-160	Franklin 6"-30	1909	1214	130	100
	Franklin 8"-30	1604	909	142	116
ECV 8-40-180	Franklin 8"-30	1819		158	
ECV 8-65-55	Franklin 6"-15	1422	874	93	66
ECV 8-65-70	Franklin 6"-18.5	1532	919	105	70
ECV 8-65-90	Franklin 6"-26	1669	1114	131	90
ECV 8-65-110	Franklin 6"-30	2039	1214	133	100
	Franklin 8"-30	1734	909	149	116
ECV 8-65-125	Franklin 8"-37	1896	986	166	131
ECV 10-65-65	PEDV 18.5-180	1303	780	137	91
	PEDV 18.5-235	1123	600	142	96
ECV 10-65-100	PEDV 25-180	1604	1010	161	105
	PEDV 25-235	1239	645	157	101
ECV 10-65-125	PEDV 32-180	1675	1010	164	110
	PEDV 33-235	1350	685	161	107
ECV 10-65-160	PEDV 37-235	1456	795	205	114
ECV 10-65-200	PEDV 50-235	1627	820	212	150
ECV 10-65-225	PEDV 55-235	1728	850	230	163
ECV 10-65-250	PEDV 63-235	1884	935	252	183
ECV 10-65-300	PEDV 75-235	2030	1010	267	195
ECV 10-65-325	PEDV 80-235	2140	1050	285	209
ECV 10-120-40	PEDV 18.5-180	1660	780	152	91
	PEDV 18.5-235	1480	600	157	96
ECV 10-120-60	PEDV 32-180	1940	1010	176	110
	PEDV 33-235	1615	685	173	107
ECV 10-120-80	PEDV 37-235	1700	720	222	114
ECV 10-120-100	PEDV 45-235	1930	790	254	146
ECV 10-120-120	PEDV 55-235	2040	850	276	163
ECV 10-120-140	PEDV 63-235	2175	935	301	183
ECV 10-120-160	PEDV 75-235	2300	1010	318	195
ECV 10-120-180	PEDV 80-235	2390	1050	337	209
ECV 10-120-200	PEDV 90-235	2450	1060	353	218
ECV 10-65-65	Franklin 6"-18.5	1442	919	142	70
ECV 10-65-100	Franklin 6"-26	1708	1114	157	90
ECV 10-65-160	Franklin 8"-37	1876	1140	205	140
ECV 10-65-200	Franklin 8"-55	2147	1340	212	179
ECV 10-120-60	Franklin 8"-30	1839	909	182	116
ECV 10-120-80	Franklin 8"-37	2120	1140	222	140
ECV 10-120-100	Franklin 8-45	2370	1230	254	156
ECV 10-120-120	Franklin 8"-55	2530	1340	276	179

PERFORMANCE CURVE

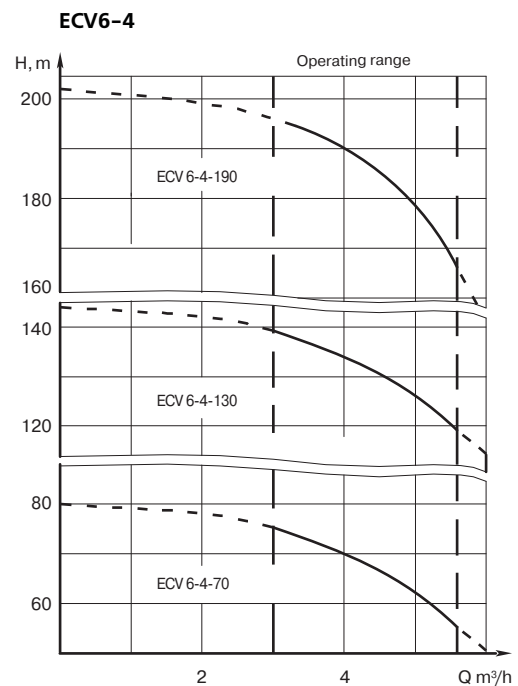
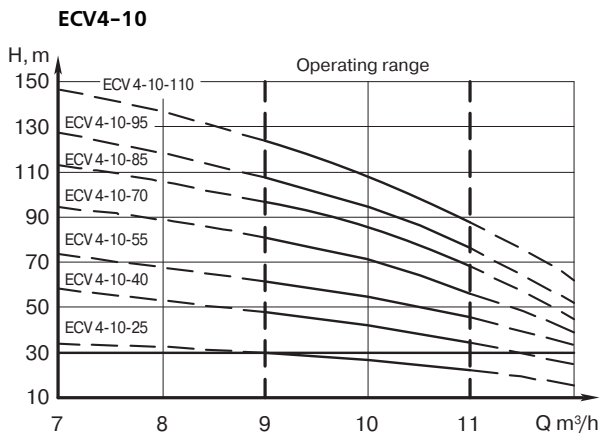
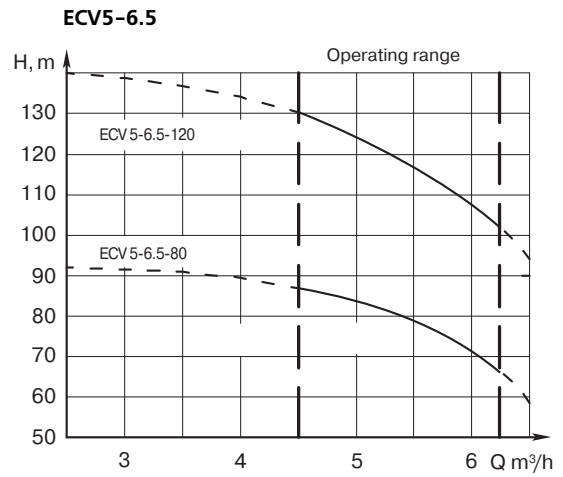
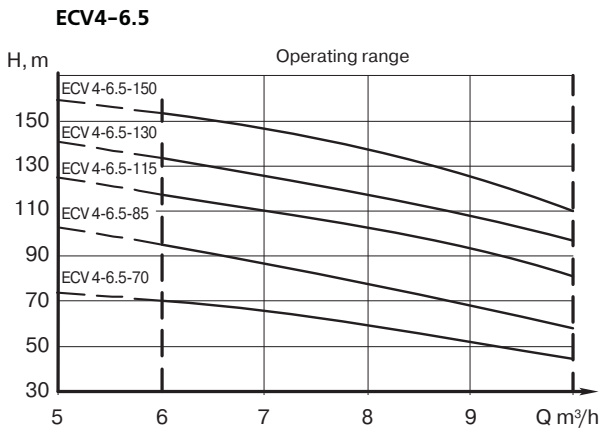
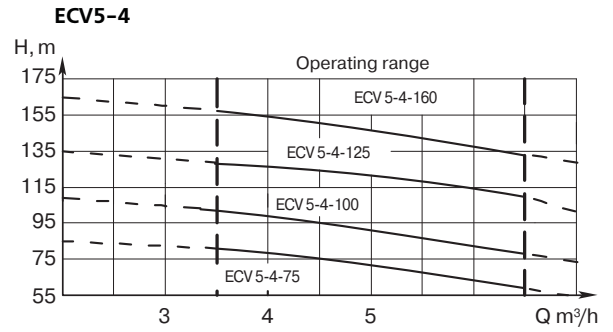
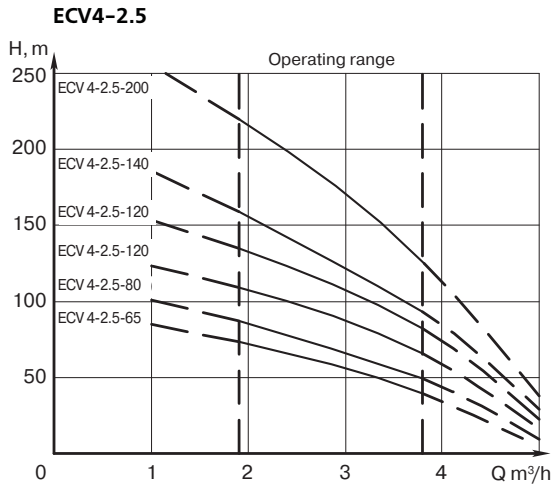

PERFORMANCE CURVE

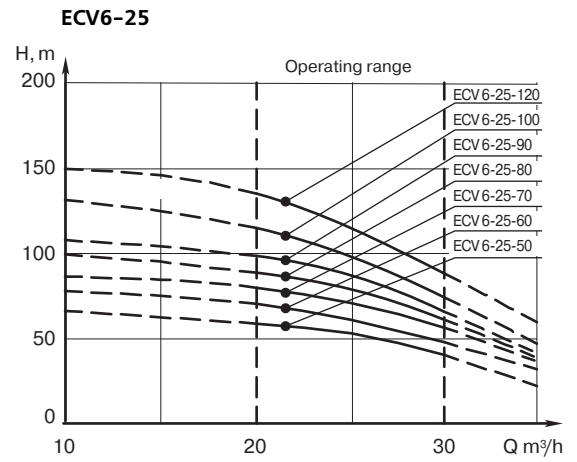
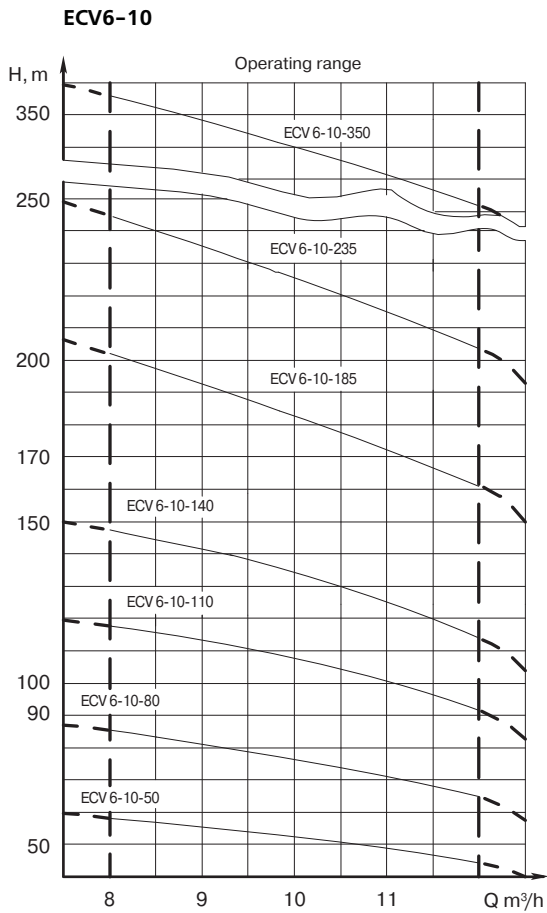
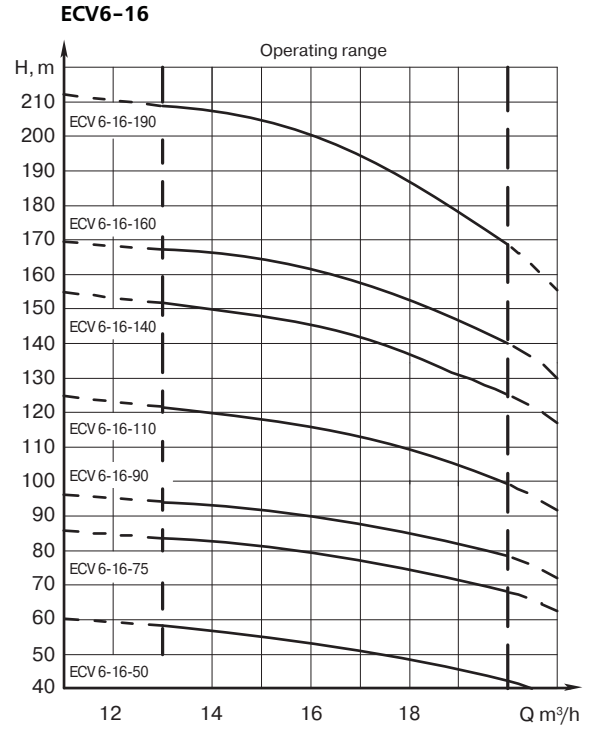
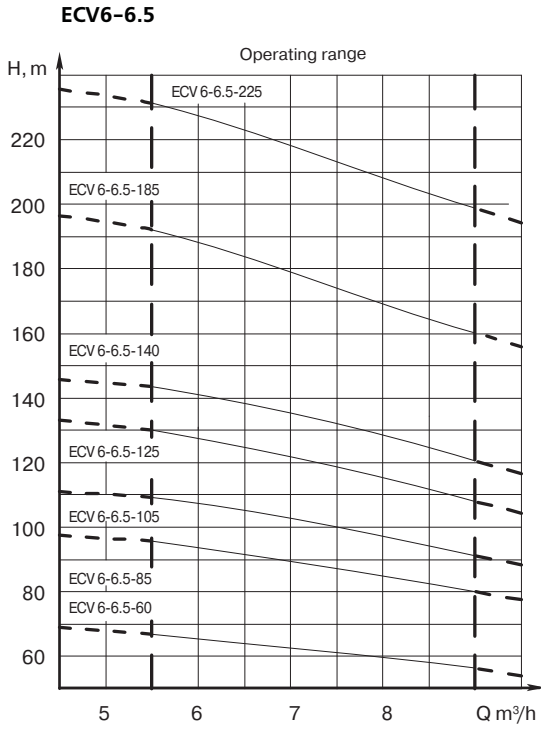

PERFORMANCE CURVE

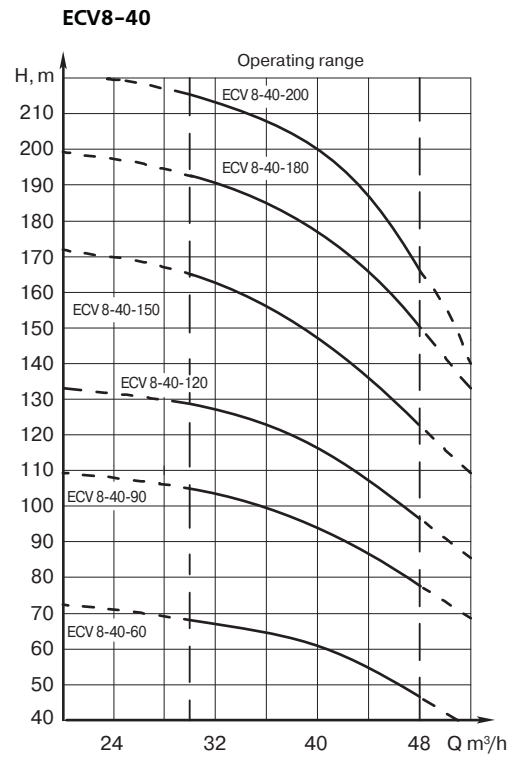
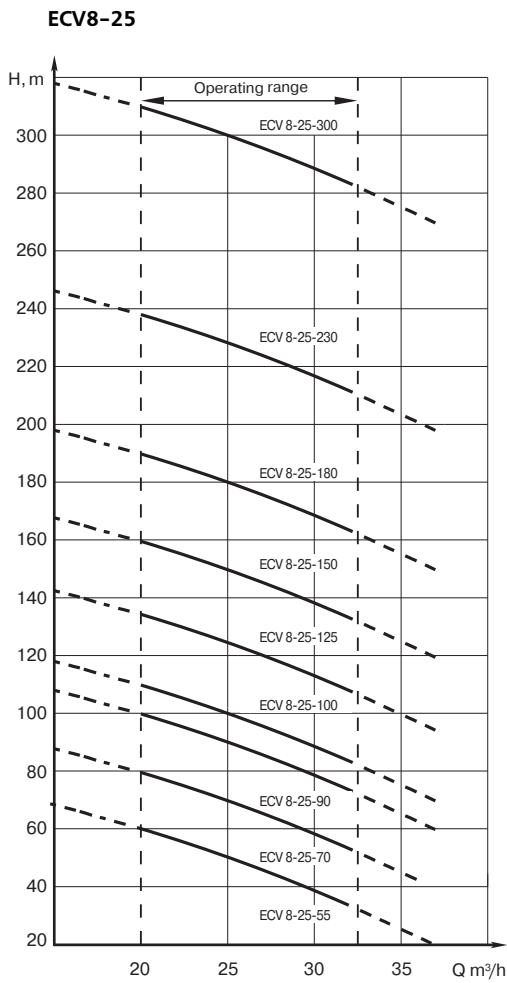
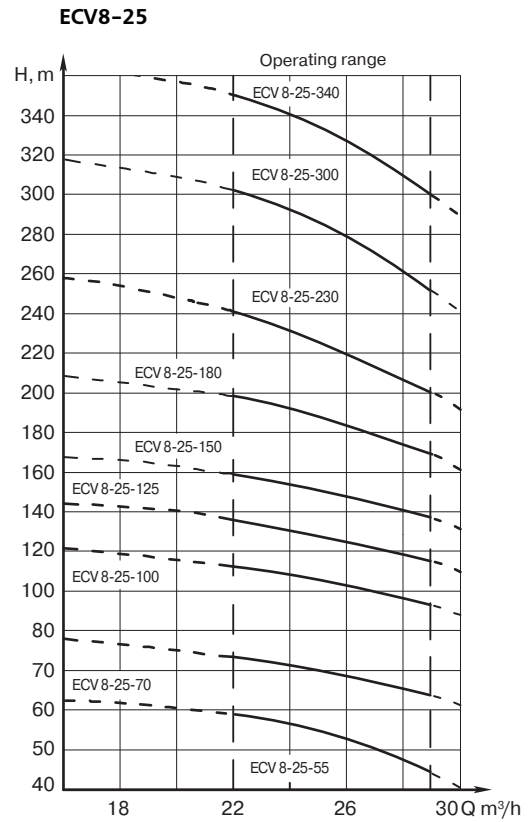
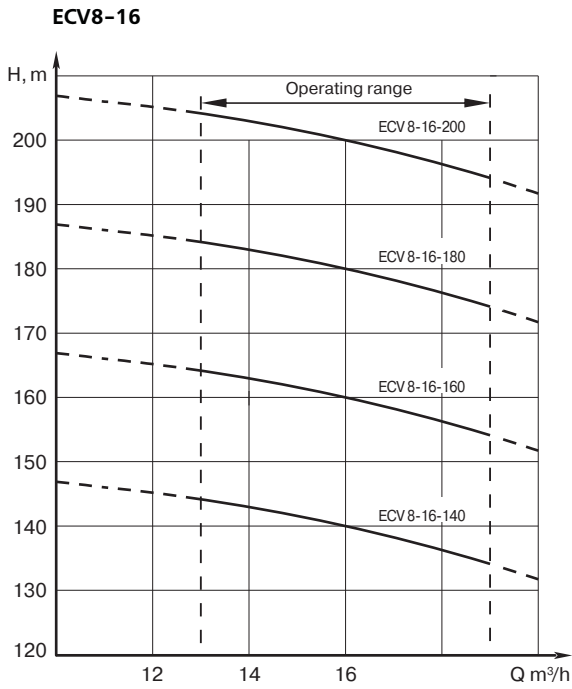

PERFORMANCE CURVE

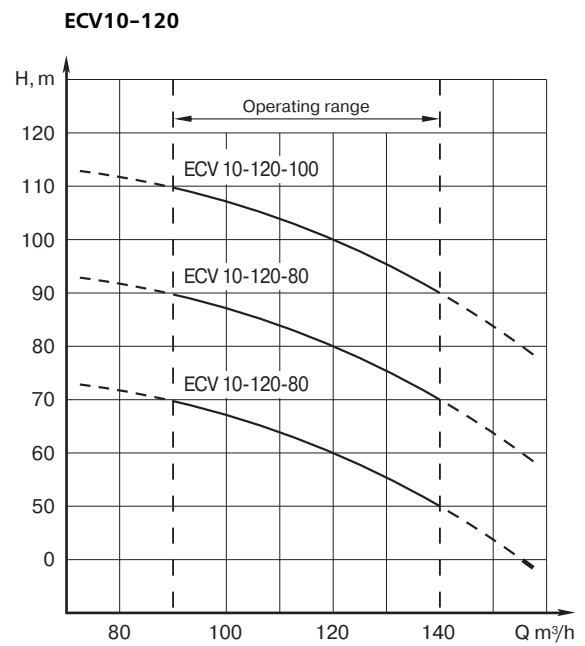
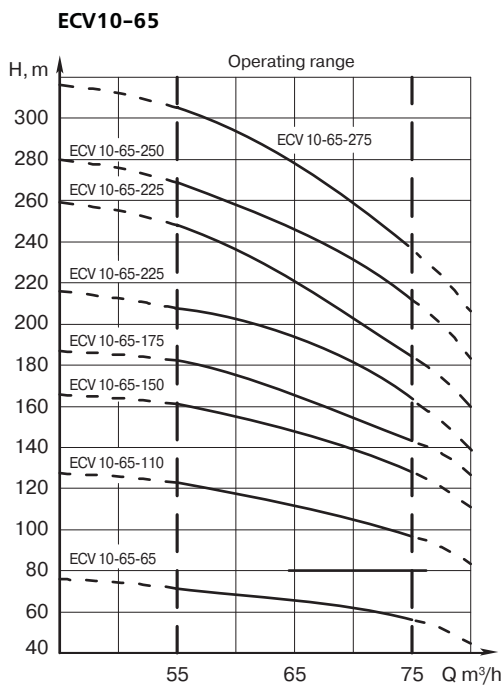
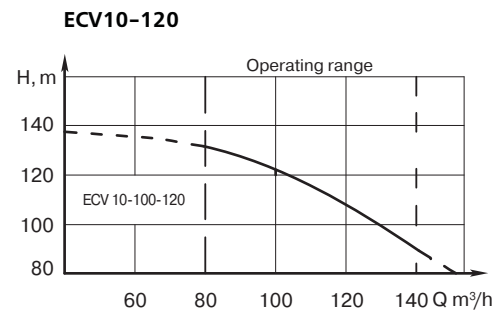
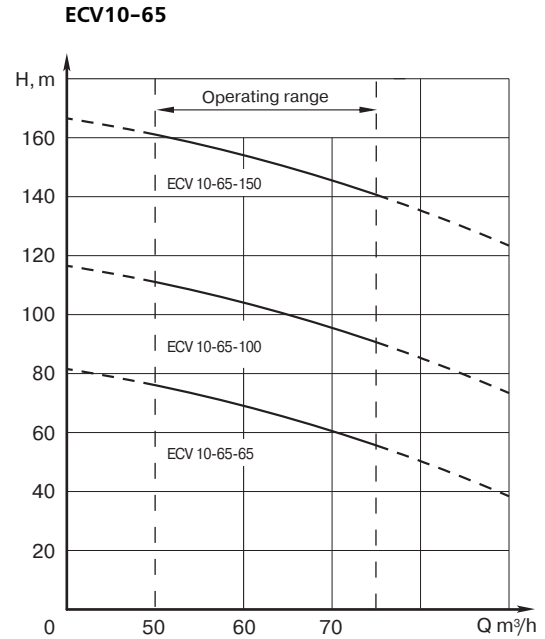
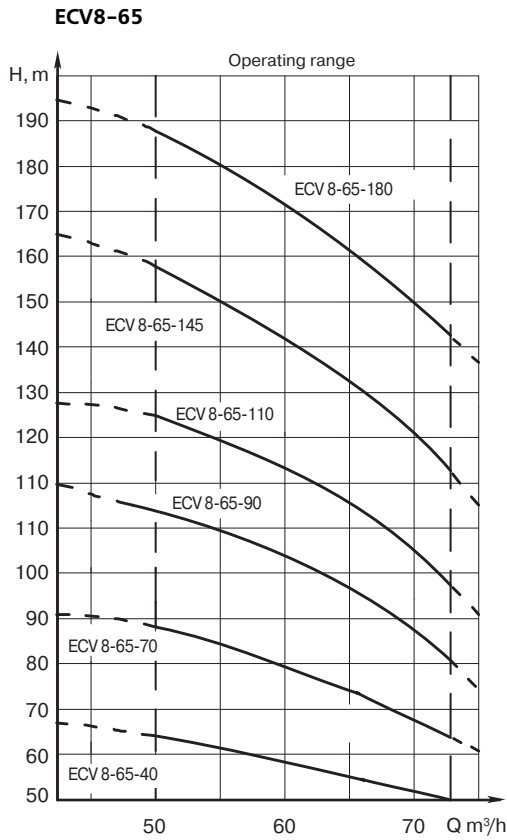

PERFORMANCE CURVE

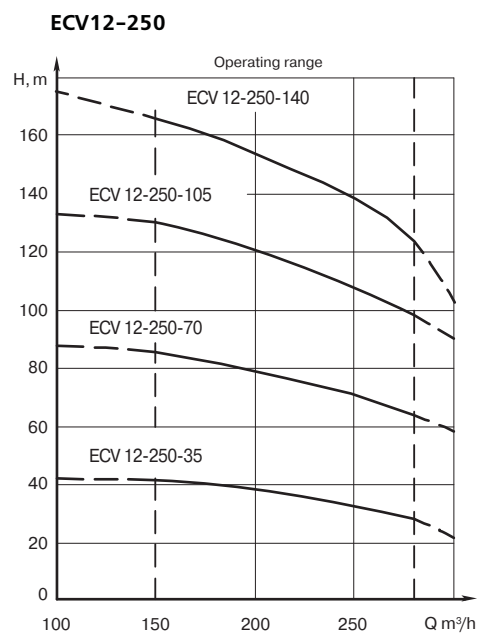
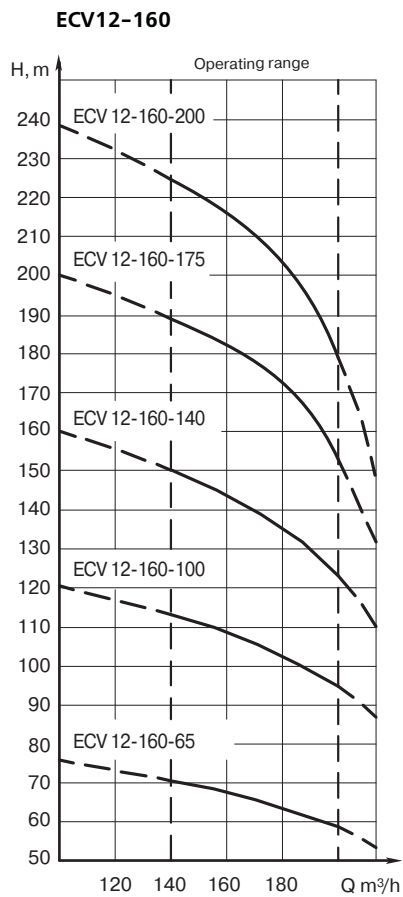
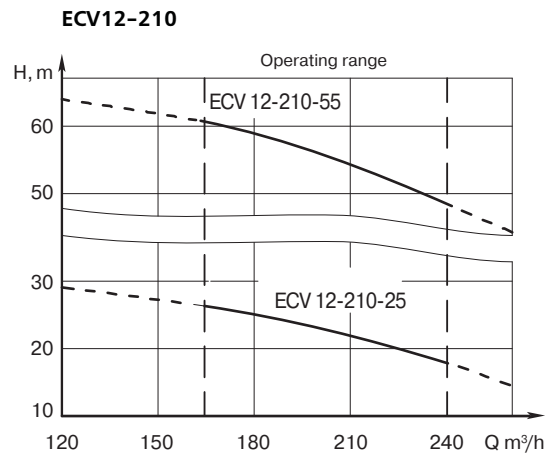
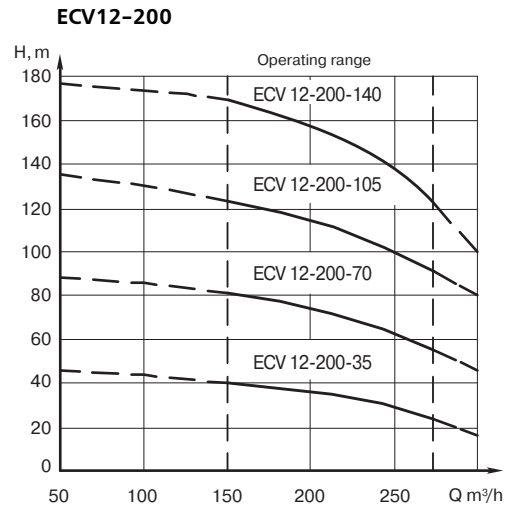
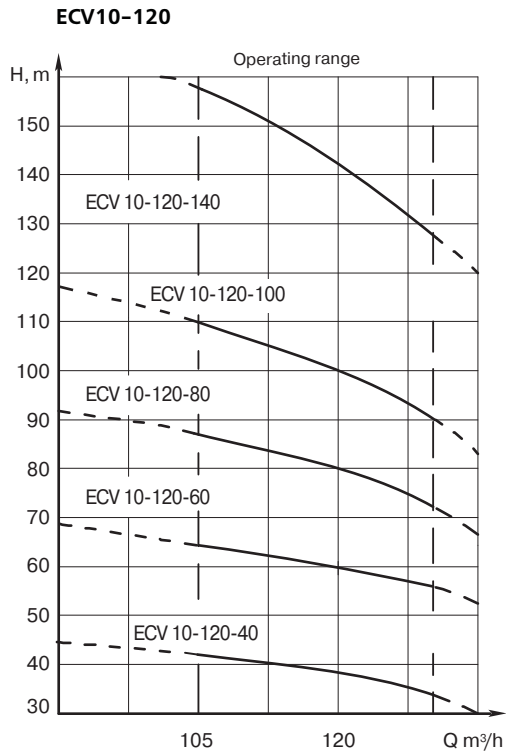

ELECTRIC MOTOR CONTROL AND PROTECTION UNIT – SUIZ «LOTSMAN+»

APPLICATION

Control and protection unit **SUIZ «Lotsman+»** is intended for automation of a process of filling liquids in containers. The unit can operate both in automatic and manual modes.

The unit can be used for equipment of any executive devices comprising three-phase asynchronous electric motors.

The unit carries out start/shutdown of a device electric motor and provides its protection. Setting of the unit operational parameters can be done within a minute and doesn't require any instruments for adjustment.



The control unit provides:

- setting of the unit operating mode – manual /automatic by external signal/by timer and low-level indicator;
- selection of filling or drainage function;
- selection of used sensors type – electric-contact manometer (ECM) or single contact level sensors;
- setting of maximum/minimum protection current depending on the used electric motor type - from 1 to 250 A;
- motor shutdown in case of increase/decrease of the set current within 1-15 seconds;
- motor interlock in case of fault to frame;
- unit interlock in case of phase loss;
- motor shutdown in case of phase shift;
- starting current measurement blocking for a period of 1 to 10 seconds;
- motor shutdown in case of voltage rise/dip within 15 seconds;
- display of electric motor operating current values in the LED indicator;
- restart after emergency situation in 1-15 seconds after protection operation;
- LED indication of sensors condition;
- sound and LED indication of operation modes and emergency situations;
- «dry contact» control of sensors: «dry operation», high level, low level, pressure sensor of ECM type.

TECHNICAL PARAMETERS

number of connected sensors	3
number of power lines	1
protection actuation time, s	1-15
wait time after fault, min	1-15
min./max. protection current, A (depending on the version)	1-250
power circuit nominal voltage, V	~380
microcontroller power supply nominal voltage, V	~220
nominal voltage of level sensor power circuits, V	=15
power voltage current frequency, Hz	50+2
allowable voltage deviation from the nominal value, %	+10 -15
consumed power, VA, maximum	22
casing protection level	IP20 (IP31)
overall dimension, mm, maximum	300x400x160 (400x500x220)
weight, kg, maximum	22
installation method	wall mounting
operating temperature, °C	-40 ... + 40

MANUAL CONTROL

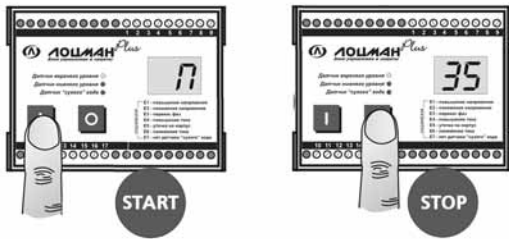

OPERATION BY EXTERNAL CONTROL SIGNAL

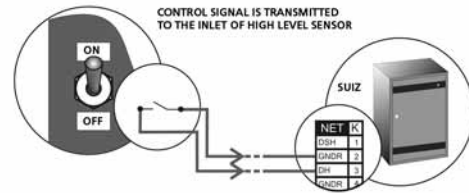

OPERATION USING ELECTRIC CONTACT MANOMETER

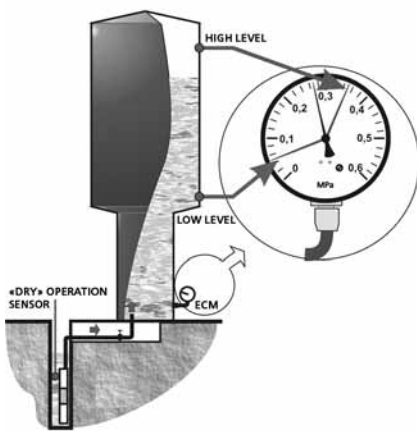

OPERATION USING SINGLE LEVEL SENSORS

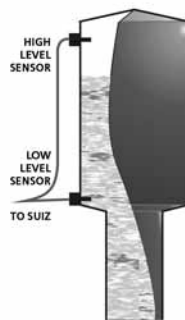

DRAINAGE OPTIONS

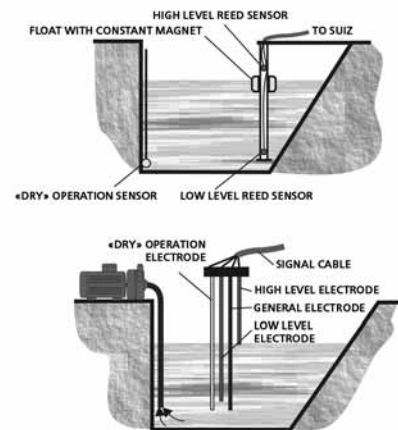

USING VARIOUS TYPES OF SENSORS

OPTION OF «DRY» OPERATION SENSOR CONNECTION

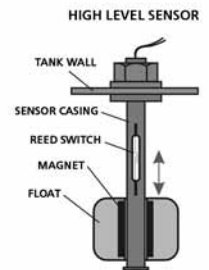
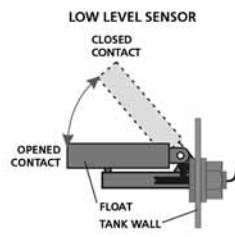
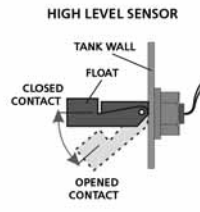
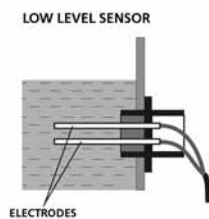
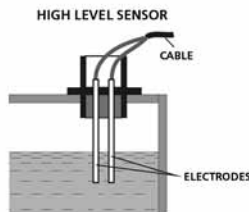
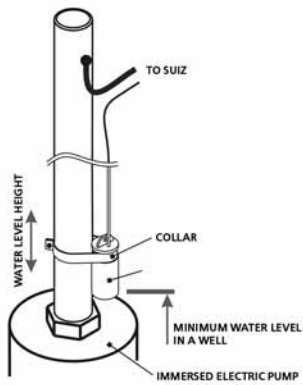

VERSIONS

version	electric motor current. A	overall dimensions. mm	weight. kg. max
«Lotsman+» -20	0 - 20.0	300x400x160	8.0
«Lotsman+» -40	2.0 - 40.0		
«Lotsman+» -80	4.0 - 80.0		
«Lotsman+» -100	14.0 - 110.0	400x500x220	16.0
«Lotsman+» -160	25.0 - 160.0	500x650x220	22.0
«Lotsman+» -250	30.0 - 250.0		

ELECTRIC MOTOR CONTROL AND PROTECTION UNIT – SUZ

APPLICATION

Control unit **SUZ** (hereinafter referred to as the unit) is intended for automatic (in level and pressure, in water rise or drainage modes) remote and local control of three-phase electric motors of immersed pumps and their protection against current overload, short circuit, open-phase operating conditions and «dry» operation.

In the automatic mode the unit provides control using signals of the high and low level sensors installed in a tank, electric contact manometer (contact type 3, 4, 5, 6), or a pressure relay.

In the remote control mode the unit provides control by a double-wire line (up to two kilometers).

In the local control mode the unit is switched on and off by an automatic switch.

The unit has an integrated current overload simulator making it possible to adjust the unit according to the electric motor current without any auxiliary instruments.

The unit provides for interlock for the time of hydraulic impact action. The interlock time is adjustable.

The unit has an option of transmission of an emergency signal outside the unit.

All control circuits have galvanic separations.

In all modes the unit provides:

- electric motor shutdown in case of failure of any of the three phases;
- electric motor shutdown in case of current overload (in one or three phases);
- electric motor shutdown in case of absence of water in the well;



- light alarm of current overload, open-phase operating conditions, «dry» operation, low voltage and operating electric motor; in automatic mode – level of water in the collection tank (in relation to the level sensors);
- operating mode recovery after termination of emergency action, start delay time is adjustable;
- indication of current consumed in one of the electric motor phases;

The unit is intended for use in indoor area without artificially controlled environmental conditions:

- ambient air temperature: from -45 °C to +40 °C;
- relative air humidity up to 98% at +25 °C;
- altitude above sea level up to 1000 m;
- environment is non-explosive, not containing current-conducting dust, aggressive gases and vapors.

TECHNICAL PARAMETERS

functions and parameters of units	SUZ-10 1–3 kW	SUZ-40 3–13 kW	SUZ-100 13–45 kW	SUZ-200 45–90 kW
main circuit nominal voltage, V	~3x380V	~3x380V	~3x380V	~3x380V
controlled electric motor power, kW	1-3	3-13	13-45	45-90
main circuit maximum current, not above, V	10	40	100	200
unit supply voltage, V	220±22	220±22	220±22	220±22
control circuit voltage, V	12	12	12	12
overall dimension, mm, maximum	320x330x160	320x330x160	505x460x250	710x680x320
weight, kg, maximum	10	10	24	55

CONNECTION SCHEME

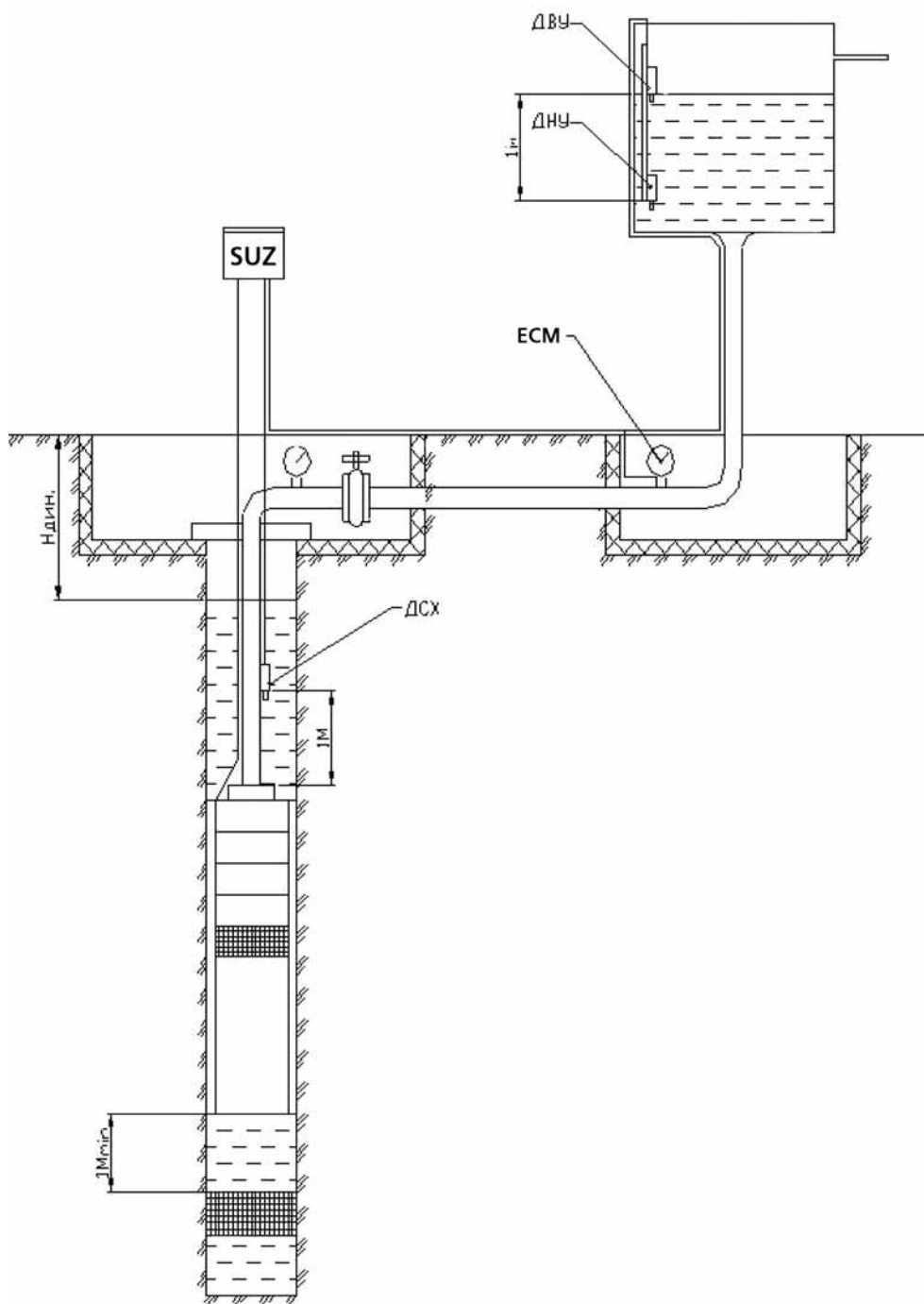

ELECTRIC MOTOR CONTROL AND PROTECTION UNIT – SUZ «RODNIK»

APPLICATION

Control and protection units «Rodnik» are intended for automatic control and protection against emergency conditions of electric pump units with three-phase motors used for water rise from wells and tanks, irrigation and water drawdown, including in group mode.

The group consists of three units of different complexity levels: «Rodnik 1», «Rodnik 2» and «Rodnik 3» exhibiting a uniformity of circuit, design and program solutions, and also, a uniformity of setting methods and procedures. The units are different in the number of functions, number of necessary settings, presence or absence of telemetry. All the units are equipped with digital ampere-meters and provide the full range of pump unit protection.

«Rodnik 1» unit — a simple variant of a general low-power unit (up to 11 kW). The unit consists of an automatic switch, starter and single-board controller «Slog-3», assembled in circuit on a metal box mounting panel. The unit is notable for its low price and extremely low (only two) number of settings. However, the unit carries out all the functions of control and protection of pump units for any operations:

- control modes using electric contact manometer;
- drainage according to electric contact level sensors;
- control using pressure relay or remote contact;
- water rise using electric contact level sensors.

For setting the operator inputs only the required operation mode and protection shutdown current; besides, the latter can be inputted directly, by its numerical value, or automatically, in the course of a trail start, pressing only one button.

Versions: 1.1–2.2 kW; 3–11 kW.

«Rodnik 2» unit is intended for companies requiring group operation of units, remote control and other complex operation algorithms.

In addition to the functionality of the previous unit there are following functions: selective self-start, timers of filling and drainage, possibility of regulation of control pauses after each starter switching, adjustable protection against load failure (minimum current), adjustable timers for automatic emergency reset, adjustable timers of command execution delay for operation as a part of a reserved group, adjustable setting of a pump start time. When minor control modes are selected, the unit is set similar to



the previous one, in which case it is necessary to input only two parameters, the rest are not displayed and do not influence the operation as the factory setting are applicable. In senior control modes it is convenient to use an integrated «notebook» to save the selected parameters and their quick recovery afterwards. There are ready sets of factory settings available. They can be recalled and edited.

The unit provides reserving in pair with a similar unit controlled by ECM or pressure relay with manual switchover of start priorities.

The unit can be controlled remotely by means of ECM, pressure relay or control buttons using any cable up to 10 km long without any auxiliary devices (relays or current sources), in which case at distances of up to 2 km it is not necessary to lay the cable separately from the power cables.

For remote indication a dry closing control contact of the starter is located on the control terminal.

The unit is manufactured with the power rating from 1 to 65 kW.

Versions: 1.1–2.2 kW; 3–11 kW; 11–32 kW; 32–45 kW; 45–65 kW.

TECHNICAL PARAMETERS	
parameter	value
supply line nominal voltage	400B, 50Hz
allowable deviation of the supply line voltage, %	± 15
starter nominal current:	
— for P<3 kW, A	10
— for P<5.5 kW, A	16
— for P<7.5 kW, A	25
— for P<15 kW, A	40
— for P<22 kW, A	63
— for P=32 kW, A	100
— for P=45 kW, A	160
voltage of circuits of level contact sensors, V	~12
current in the contact sensors circuit, mA	<2
electric strength of the main circuits insulation, V	660
resistance of the main circuits insulation measured in cold state with megohmmeter for 500 V, minimum, megohm	10
class of protection against electric-shock hazard under GOST 12.2.007.0-75	1
grounding system type	TN-C
cover protection level under GOST 14254-80	IP40, IP54
unit climatic version	UZ (premise)
overall dimension H*L*B, mm	
— up to 11 kW	400x375x175
— up to 32 kW	560x420x200
— up to 65 kW	800x600x300
mounting method	mounted
maximum weight, kg	
— up to 11 kW	8
— up to 32 kW	15
— up to 65 kW	30

ELECTRIC MOTOR CONTROL AND PROTECTION UNIT – SUZ «SIGNAL»

APPLICATION

The unit operates in the following modes:

- manual start and shutdown of electric pump;
- manual start and automatic shutdown by integrated timer after a set period of time from 10 to 150 minutes with increment of 10 minutes;
- manual start and automatic shutdown by signals of electrode sensor of high (for drainage – low) level or electric contact manometer (ECM);
- automatic start and shutdown by commands of level or pressure sensors;
- automatic start by signal of low level sensor or ECM, shutdown by timer command; when operating in this mode, and also, when control is carried out by ECM, tower frosting is excluded;
- mode for editing timer settings, current protection and control algorithms stored in permanent memory;
- adjustment mode intended for prestart unit adjustment.

The unit performs:

- prestart checking of electric network parameters, preventive and emergency control of insulation resistance of a system cable-electric motor;
- constant checking in the course of the device operation of useful currents in all phases; in case of useful currents increase or decrease automatic shutdown is performed through a delay inversely proportional to the overload; after emergency shutdown due to overload both manual and automatic unit restart is possible after a particular delay;
- adjustable shutdown delay according to ECM signal for compensation of a hydraulic impact;
- protection against dry cold by means of an electrode sensor or current control, automatic restart upon recovery of water level and adjustable extra delay;
- constant checking in the course of the device operation of voltage in all phases; in case of system voltage deviation beyond the limit values, and also, in case of failure of phase conductor, the pump is switched off; after normalization of the system parameters by means of delay the pump is automatically restarted;
- when operating in the adjustment mode indication is displayed establishing the nominal current protection setting for the device;



- in case of failure of the starter contact group or loss of contact in the circuit device-unit diagnostic indication is displayed;
- there is indication of increased and decreased useful current in any phase, indication of operation of level sensors and dry cold.

Versions: 1.1-5.5 kW; 6.3-11 kW; 12-18 kW; 18.5-25 kW; 25-32 kW; 32-45 kW; 45-65 kW.

TECHNICAL PARAMETERS	
parameter	value
power circuit voltage, V	380±15%
frequency, Hz	50±1
load current, depending on the modification, A	0,5 - 100
sensor supply voltage, V	36±15%
voltage of measurement of insulation resistance - pulsing of positive polarity (amplitude), V	120±20%
initial delay after energizing, s	10±20%
shutdown delay according to dry cold signal, s	2±20%
unit start delay after fading of dry cold signal (moistening of dry cold sensor), min	10 or 20±10%
active condition of level sensors — closed to the grounding or opened (any of the possible combinations depending on the consumer requirements)	
cover protection level	IP40 or IP54 under GOST14254-80
unit climatic version	UZ (premise)
unit dimension and weight depending on the power of the device controlled:	
— up to 11 kW	400x375x175 mm, 8 kg
— up to 32 kW	560x420x200 mm, 15 kg
— up to 65 kW	800x600x300 mm, 30 kg

CENTRIFUGAL MULTISTAGE PUMPS OF CNSg TYPE AND ELECTRIC PUMP UNITS ON THEIR BASIS

APPLICATION

Centrifugal multistage pumps of **1CNSg** type and electric pump units on their basis are intended for pumping of water with hydrogen index (pH)=7-8.5, temperature not more than 105°C, weight ratio of solid mechanical impurities not more than 0,1%, with the solid particles size not more than 0.1 mm, micro-hardness not more than 1,47 hPa (14700 kgf/cm²).

Pumps **1CNSg** and units on their basis are used in thermal power industry for supply of feed water to steam boilers of boiler houses of low power steam electric plants and in heating and hot water supply systems.

The pumps are manufactured in climatic versions UHL and T of location categories 4 and 2 under GOST 15150-69.

The base pumps (units) are not intended for operation in explosion and fire hazardous premises.

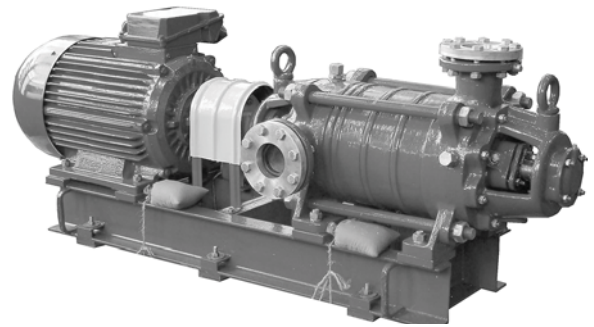

PERFORMANCE RANGE

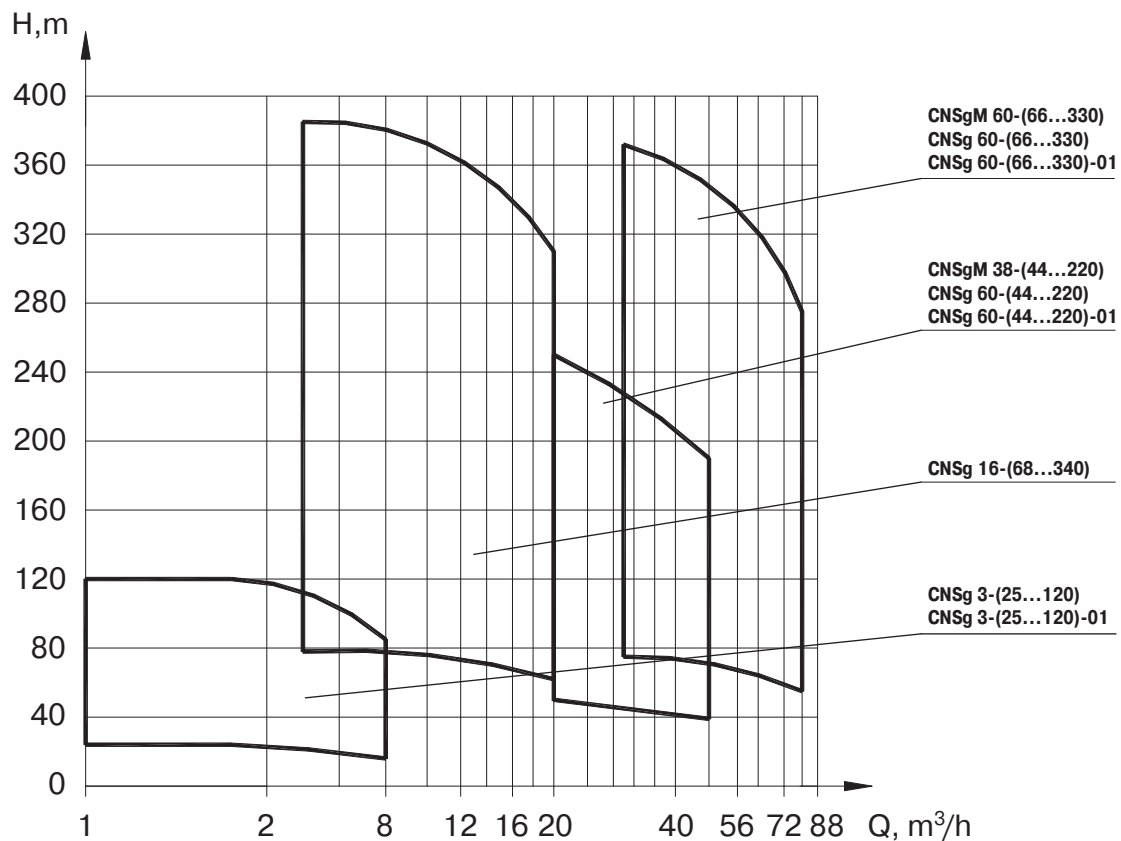

PUMP TYPE KEYS

Example of designation:
1CNSg 40-44-1 UHL4

1CNSg XX - XX - X УХЛХ

centrifugal multistage pump
for hot water

capacity, m³/h

head, m

version with a screw
(improved cavitation performance)

designation of climatic version
and location category

Example of designation:
CNSg 38-132-01

CNSg XX - XXX - XX

centrifugal multistage pump
for hot water

capacity, m³/h

head, m

explosion-proof version

TECHNICAL PARAMETERS

pump model	capacity, m ³ /h, (m ³ /s)	head, m	rotation speed, s ⁻¹ (rpm)	pump power input, kW	net positive suction head, m	pump efficiency, %, min.	pump weight, kg
CNS 3-25	3.0 (0.00083)	24	47.3 (2840)	0.52	4.0	38	24
CNS 3-25-1						38	25.8
CNS 3-36		36		0.77		38	26
CNS 3-36-1						38	28.4
CNS 3-45		48		0.87		41	28
CNS 3-45-1						41	31
CNS 3-60		60		1.09		41	31
CNS 3-60-1						41	33.5
CNS 3-75		72		1.31		41	33.3
CNS 3-75-1						41	37.2
CNS 3-85		84		1.53		45	35.3
CNS 3-85-1						45	39.8
CNS 3-100		96		1.74		45	36.5
CNS 3-100-1						45	42.4
CNS 3-108		108		1.96		45	38.2
CNS 3-108-1						45	45
CNS 3-120		120		2.18		45	40
CNS 3-120-1						45	47.5

TECHNICAL PARAMETERS										
pump model	capacity, m ³ /h, (m ³ /s)	head, m	rotation speed, s ⁻¹ (rpm)	pump power input, kW	net positive suction head, m	pump efficiency, %, min.	pump weight, kg			
CNSg 16-68	16 (0.0044)	68.0	49 (2940)	7.7	3	42	240 (395)			
CNSg 16-102		102.0		11.6		42	265 (475)			
CNSg 16-136		136.0		15.4		42	290 (510)			
CNSg 16-170		170.0		18.9		42	315 (550)			
CNSg 16-204		204.0		22.6		43	340 (595)			
CNSg 16-238		238.0		26.4		43	365 (640)			
CNSg 16-272		272.0		28.9		44	390 (670)			
CNSg 16-306		306.0		32.6		45	415 (690)			
CNSg 16-340		340.0		36.2		45	440 (720)			
CNSg 38-44		38 (0.0106)		44.0		49(2940)	8.2	3.6	67	251
CNSg 38-44-01	66.0		12.4	67	281					
CNSg 38-66			88.0	16.2	68		311			
CNSg 38-66-01	110.0			20.0	69		341			
CNSg 38-88			132.0	23.9	69		371			
CNSg 38-88-01	154.0			27.9	69		401			
CNSg 38-110			176.0	30.0	69		431			
CNSg 38-110-01	198.0			35.9	69		461			
CNSg 38-132			220.0	39.9	69		491			
CNSg 38-132-01	44.0			8.2	67		220			
CNSg 38-154			66.0	12.4	67		240			
CNSg 38-154-01	88.0			16.2	68		260			
CNSg 38-176			110.0	20.0	69		280			
CNSg 38-176-01	132.0			23.9	69		300			
CNSg 38-198			154.0	27.9	69		320			
CNSg 38-198-01	176.0			30.0	69		340			
CNSg 38-220			198.0	35.9	69		360			
CNSg 38-220-01	220.0			39.9	69		380			
CNSgM 38-44	60 (0.0167)		66.0	49(2940)	18.8		4.5		70	280
CNSgM 38-66			99.0		28.9				70	
CNSgM 38-88		132.0			37.7	70		330		
CNSgM 38-110			70		380					
CNSgM 38-132		70								
CNSgM 38-154		70								
CNSgM 38-176		70								
CNSgM 38-198		70								
CNSgM 38-220		70								
CNSg 60-66		60 (0.0167)	66.0		49(2940)	18.8		4.5	70	280
CNSg 60-66-01	99.0		28.9	70						
CNSg 60-99			132.0	37.7		70	330			
CNSg 60-99-01	70									
CNSg 60-132	70									
CNSg 60-132-01	70									

TECHNICAL PARAMETERS

pump model	capacity, m ³ /h, (m ³ /s)	head, m	rotation speed, s ⁻¹ (rpm)	pump power input, kW	net positive suction head, m	pump efficiency, %, min.	pump weight, kg
CNSg 60-165	60 (0.0167)	165.0	49(2940)	44.4	4.5	71	430
CNSg 60-165-01							
CNSg 60-198		198.0		53.7		71	480
CNSg 60-198-01							
CNSg 60-231		231.0		64.4		71	530
CNSg 60-231-01							
CNSg 60-264		264.0		72.6		71	580
CNSg 60-264-01							
CNSg 60-297		297.0		79.6		71	630
CNSg 60-297-01							
CNSg 60-330		330.0		90.9		71	680
CNSg 60-330-01							
CNSgM 60-66		66		18.8		70	280
CNSgM 60-99		99		28.9		70	330
CNSgM 60-132		132		37.7		70	380
CNSgM 60-165		165		44.4		71	430
CNSgM 60-198		198		53.7		71	480
CNSgM 60-231		231		64.4		71	530
CNSgM 60-264		264		72.6		71	580
CNSgM 60-297		297		79.6		71	630
CNSgM 60-330	330	90.9	71	680			

pump (unit) model	capacity, m ³ /h, (m ³ /s)	head, m	pump inlet pressure, MPa (kgf/cm ²)	rotation speed, s ⁻¹ (rpm)	pump consumed power, kW	eff., %	number of stages	pump weight, kg	power supply			net positive suction head, m
									current	voltage, V	frequency, Hz	
1CNSg40-44	40 (0.0111)	44	0.3(3)	49.2 (2950)	9.0	62	2	180	alternating	380	50	3.6
1CNSg40-44-1	40 (0.0111)	44	0.3(3)	49.2 (2950)	9.0	62	2	180				2.0
1CNSg40-66	40 (0.0111)	66	0.3(3)	49.2 (2950)	13.0	62	3	205				3.6
1CNSg40-66-1	40 (0.0111)	66	0.3(3)	49.2 (2950)	13.0	62	3	205				2.0
1CNSg40-88	40 (0.0111)	88	0.3(3)	49.2 (2950)	17.0	62	4	230				3.6
1CNSg40-88-1	40 (0.0111)	88	0.3(3)	49.2 (2950)	17.0	62	4	230				2.0
1CNSg40-110	40 (0.0111)	110	0.3(3)	49.2 (2950)	22.0	62	5	255				3.6
1CNSg40-110-1	40 (0.0111)	110	0.3(3)	49.2 (2950)	22.0	62	5	255				2.0
1CNSg40-132	40 (0.0111)	132	0.3(3)	49.2 (2950)	27.0	62	6	280				3.6
1CNSg40-132-1	40 (0.0111)	132	0.3(3)	49.2 (2950)	27.0	62	6	280				2.0
1CNSg40-154	40 (0.0111)	154	0.3(3)	49.2 (2950)	30.5	62	7	310				3.6
1CNSg40-154-1	40 (0.0111)	154	0.3(3)	49.2 (2950)	30.5	62	7	310				2.0
1CNSg40-176	40 (0.0111)	176	0.3(3)	49.2 (2950)	36.0	62	8	335				3.6
1CNSg40-176-1	40 (0.0111)	176	0.3(3)	49.2 (2950)	36.0	62	8	335				2.0

TECHNICAL PARAMETERS

pump (unit) model	capacity, m ³ /h, (m ³ /s)	head, m	pump inlet pressure, MPa (kgf/cm ²)	rotation speed, s ⁻¹ (rpm)	pump consumed power, kW	eff. %	number of stages	pump weight, kg	power supply			net positive suction head, m
									current	voltage, V	frequency, Hz	
1CNSg40-198	40 (0.0111)	198	0.3(3)	49.2 (2950)	39.8	62	9	360	alternating	380	50	3.6
1CNSg40-198-1	40 (0.0111)	198	0.3(3)	49.2 (2950)	39.0	62	9	360				2.0
1CNSg60-66	60 (0.0167)	66	0.3(3)	49.2 (2950)	21.0	64	2	200				4.5
1CNSg60-66-1	60 (0.0167)	66	0.3(3)	49.2 (2950)	21.0	64	2	200				3.0
1CNSg60-99	60 (0.0167)	99	0.3(3)	49.2 (2950)	28.0	64	3	237				4.5
1CNSg60-99-1	60 (0.0167)	99	0.3(3)	49.2 (2950)	28.0	64	3	237				3.0
1CNSg60-132	60 (0.0167)	132	0.3(3)	49.2 (2950)	39.0	64	4	245				4.5
1CNSg60-132-1	60 (0.0167)	132	0.3(3)	49.2 (2950)	39.0	64	4	245				3.0
1CNSg60-165	60 (0.0167)	165	0.3(3)	49.2 (2950)	49.5	64	5	315				4.5
1CNSg60-165-1	60 (0.0167)	165	0.3(3)	49.2 (2950)	49.5	64	5	315				3.0
1CNSg60-198	60 (0.0167)	198	0.3(3)	49.2 (2950)	53.8	64	6	350				4.5
1CNSg60-198-1	60 (0.0167)	198	0.3(3)	49.2 (2950)	53.8	64	6	350				3.0

PERFORMANCE CURVE

1CNSg40

rotation speed 49.2 s⁻¹ (2950 rpm)
liquid – water (20 °C), density 1000 kg/m³

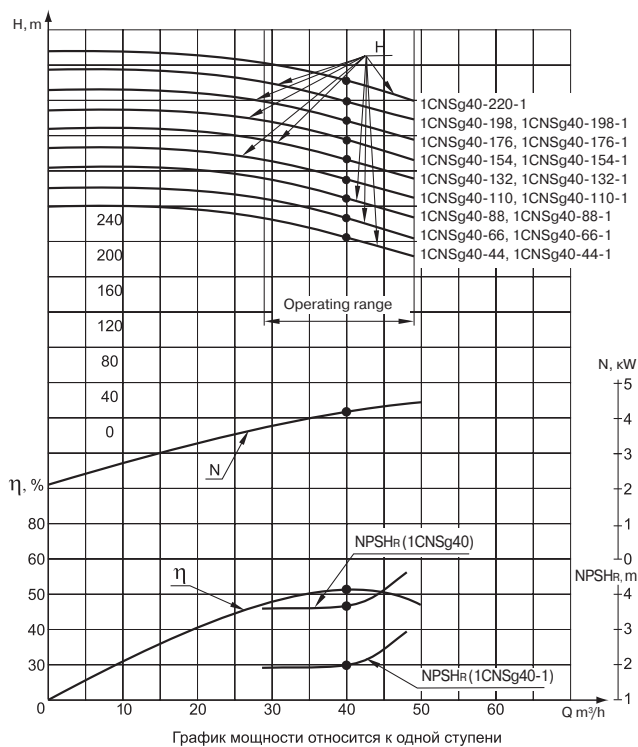

1CNSg60

rotation speed 49.2 s⁻¹ (2950 rpm)
liquid – water (20 °C), density 1000 kg/m³

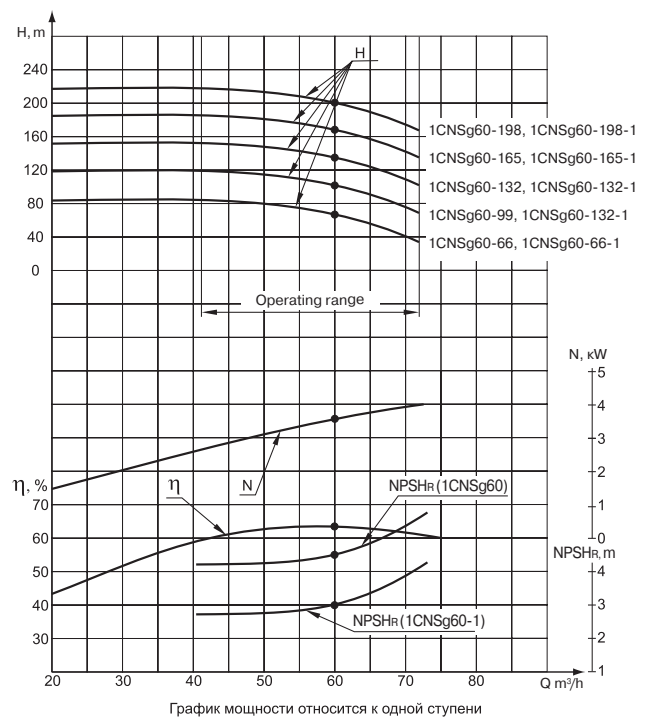

PUMP OVERALL DIMENSIONS

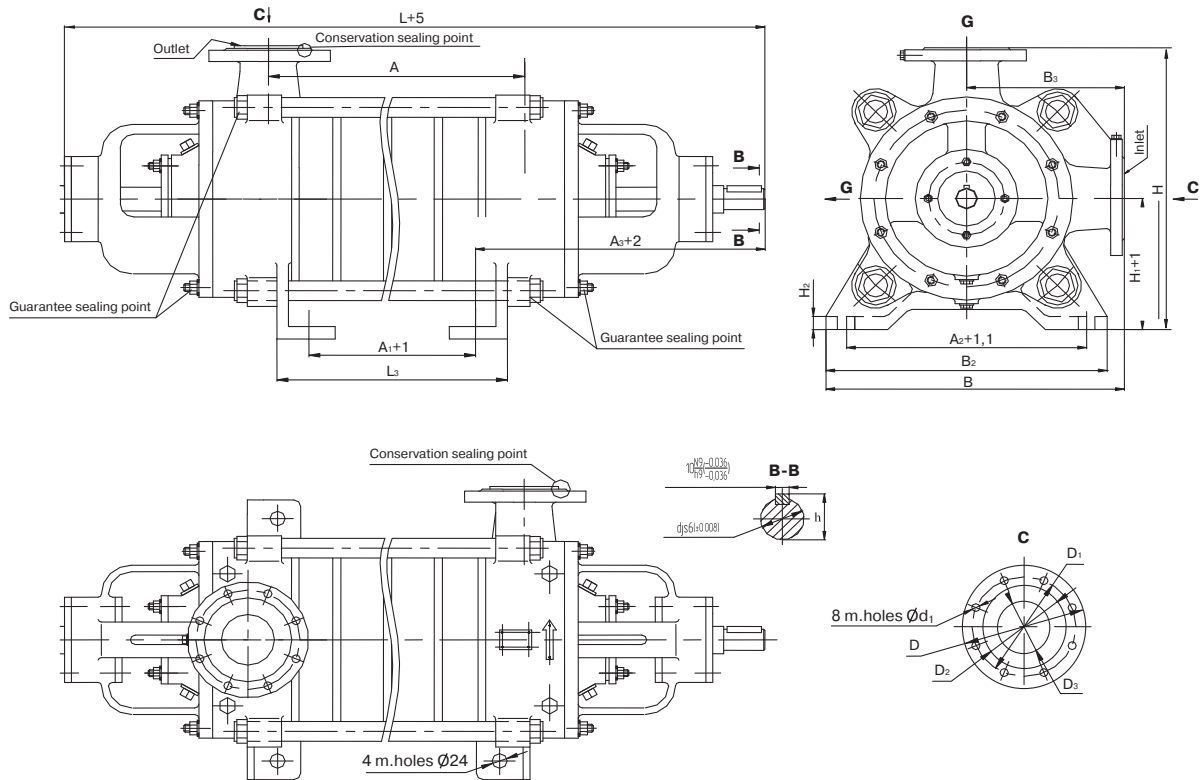

unit model	dimensions in mm																			
	L	L_3	A	A_1	A_2	A_3	B	B_2	B_3	H	H_1	H_2	D	D_1	D_2	D_3	d	d_1	h	
1CNSg40-44 1CNSg40-44-1	830	225	225	115																
1CNSg40-66 1CNSg40-66-1	913	308	308	198																
1CNSg40-88 1CNSg40-88-1	996	391	391	281																
1CNSg40-110 1CNSg40-110-1	1080	474	474	364																
1CNSg40-132 1CNSg40-132-1	1162	557	557	447	350	405	435	410	230	430	200	20	180	145	122	65	32	18		35 ^{-0,21}
1CNSg40-154 1CNSg40-154-1	1245	640	640	530																
1CNSg40-176 1CNSg40-176-1	1328	723	723	613																
1CNSg40-198 1CNSg40-198-1	1410	806	806	696																
1CNSg60-66 1CNSg60-66-1	862	241	241	111																
1CNSg60-99 1CNSg60-99-1	950	329	329	199																
1CNSg60-132 1CNSg60-132-1	1028	417	417	287	340	415	462	400	260	462	200	25	195	160	133	80	36	18		39 ^{-0,29}
1CNSg60-165 1CNSg60-165-1	1126	505	505	375																
1CNSg60-198 1CNSg60-198-1	1214	593	593	463																

OVERALL DIMENSIONS & TECHNICAL PARAMETERS

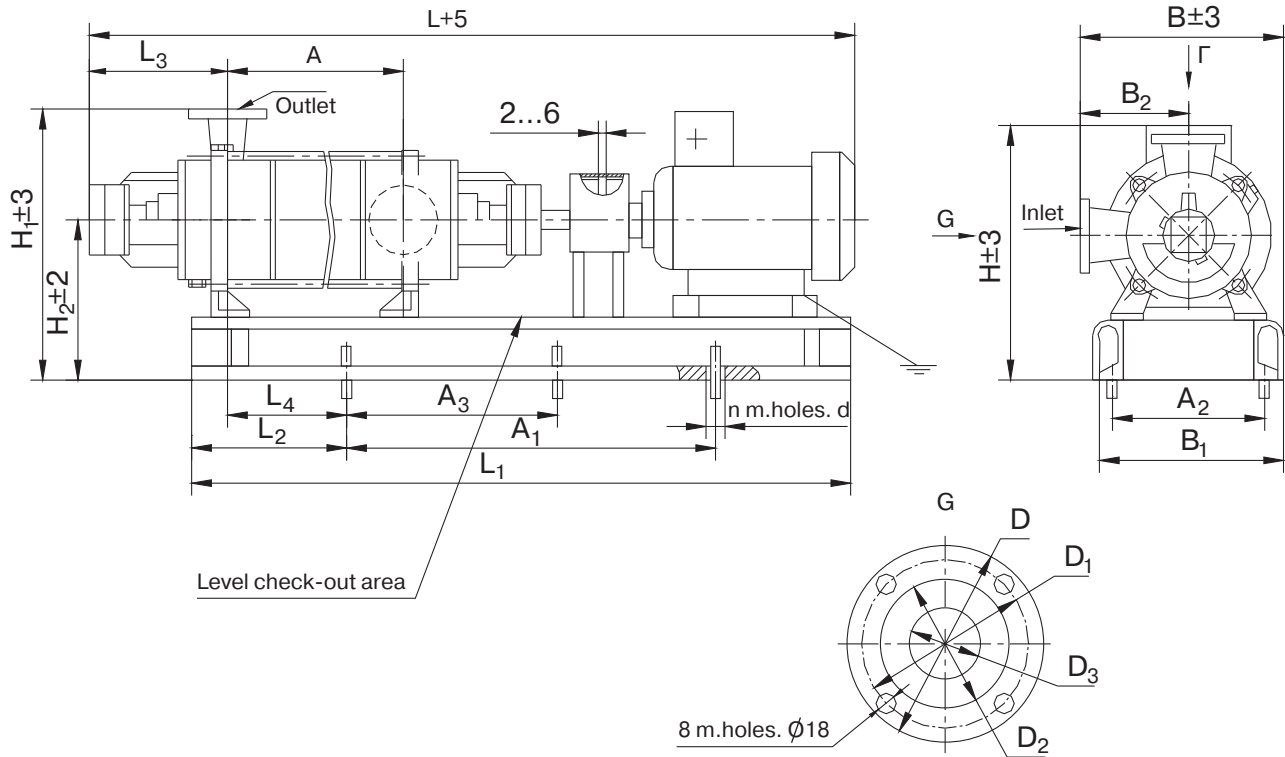

unit model	electric motor model	power, kW	dimensions in mm												
			L	L ₁	L ₂	L ₃	L ₄	A	A ₁	A ₂	A ₃				
1CNSg40-44	AIRM132M2	11	1335	990	150	254	135	225	690	350	-				
1CNSg40-44-1	AIR160S2	15	1465	1050	150						400				
1CNSg40-66	5A160S2		1590	1135	180						165	308	800	400	
1CNSg40-66-1	5A160M2	18,5	1670	1250	210						195	391	870	435	
1CNSg40-88															1715
1CNSg40-88-1	AIR180S2	22	1715	1320	250						235	474	920	460	
1CNSg40-110	AIR180M2	30	1850	1440	300						285	557	100	350	500
1CNSg40-110-1															
1CNSg40-132	A200M2	37	2140	1660	370						355	723	1080	540	
1CNSg40-132-1															2115
1CNSg40-154	5A200L2	45	2197	1785	400						385	805	1180	590	
1CNSg40-154-1	5A225M2	55	2270	1794	400						385	805	1180	590	
1CNSg60-66	AIR180S2	22	1500	1080	267						130	241	820	345	-
1CNSg60-66-1	AIR180M2	30	1550	1125											140
1CNSg60-99			1640	1210		180	210	417	-						
1CNSg60-99-1	5A200L2	45	1820	1380	220	210	417	-	-						
1CNSg60-132	5A225M2	55	1970	1495	295	285	505	1000	340	500					
1CNSg60-132-1											2060	1585	415	405	593
1CNSg60-165	5A225M2	55	1970	1495	295	285	505	1000	340	500					
1CNSg60-165-1											2060	1585	415	405	593
1CNSg60-198	5A225M2	55	2060	1585	415	405	593	1000	340	500					
1CNSg60-198-1											2060	1585	415	405	593

OVERALL DIMENSIONS & TECHNICAL PARAMETERS

unit model	electric motor model	power, kW	dimensions in mm											weight, kg		
			B	B ₁	B ₂	H	H ₁	H ₂	D	D ₁	D ₂	D ₃	d		n	
1 CNSg40-44 1 CNSg40-44-1	AIRM132M2 AIR160S2	11				553 585									4	330 380
1 CNSg40-66 1 CNSg40-66-1	5A160S2	15	440	384		622	590	360						19	6	410
1 CNSg40-88 1 CNSg40-88-1	5A160M2	18,5														455
1 CNSg40-110 1 CNSg40-110-1	AIR180S2	22			230				180	145	122	65				520
1 CNSg40-132 1 CNSg40-132-1	AIR180M2	30				680							33			560
1 CNSg40-154 1 CNSg40-154-1			460	420			650	420							6	595
1 CNSg40-176 1 CNSg40-176-1	A200M2	37				695										705
1 CNSg40-198 1 CNSg40-198-1	5A200L2 5A225M2	45 55				705 720										725 780
1 CNSg60-66 1 CNSg60-66-1	AIR180S2	22												19	4	445 463
1 CNSg60-99 1 CNSg60-99-1	AIR180M2	30	470	395		620	620	360								500
1 CNSg60-132 1 CNSg60-132-1	5A200L2	45	478		260	645			195	160	133	80				638
1 CNSg60-165 1 CNSg60-165-1														33	6	790
1 CNSg60-198 1 CNSg60-198-1	5A225M2	55	475	390		755	705	445								832

OVERALL DIMENSIONS & TECHNICAL PARAMETERS

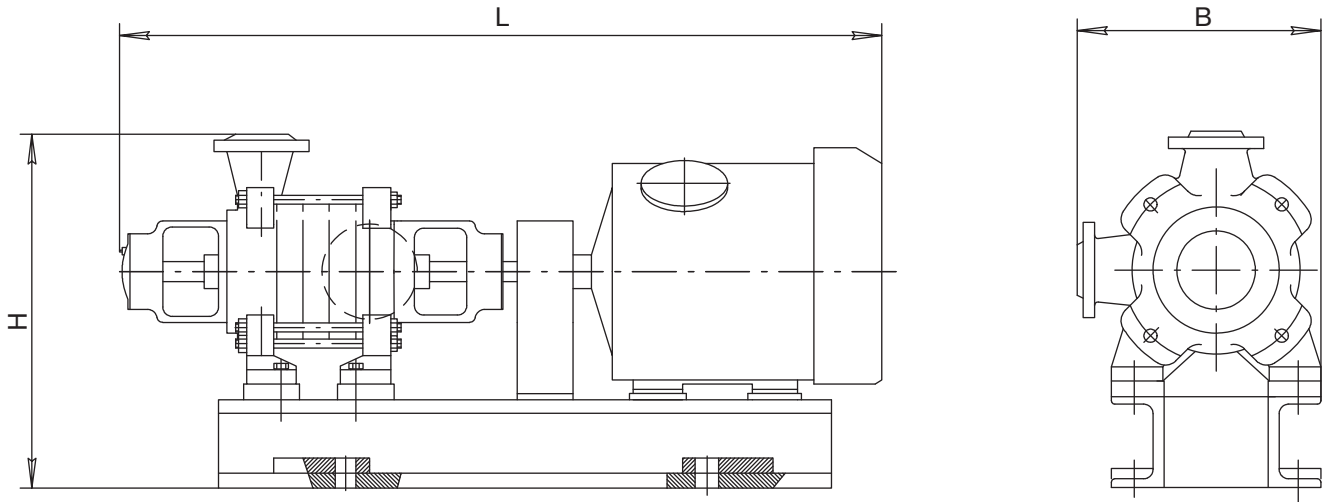

unit model	capacity, m ³ /h	head, m	rotation speed, rpm	electric motor power, kW	net positive suction head, m	overall dimensions L x B x H, mm	weight, kg
CNSA (CNSGA) 13-70	13	70	3000	11	3 (for CNS pumps)	1350x440x580	340
CNSA (CNSGA) 13-105		105		11		1420x440x580	370
CNSA (CNSGA) 13-140		140		15		1660x440x620	460
CNSA (CNSGA) 13-175		175		18.5		1760x440x620	500
CNSA (CNSGA) 13-210		210		18.5		1830x440x620	540
CNSA (CNSGA) 13-245		245		22		1830x440x610	580
CNSA (CNSGA) 13-280		280		30		1960x440x610	630
CNSA (CNSGA) 13-315		315		30		2030x440x610	660
CNSA (CNSGA) 13-350		350		30		2100x440x610	690
CNSA (CNSGA) 38-44	38	44	3000	11	3.6 (for CNS pumps)	1350x440x580	345
CNSA (CNSGA) 38-66		66		15		1610x440x690	420
CNSA (CNSGA) 38-88		88		18.5		1720x440x690	485
CNSA (CNSGA) 38-110		110		22		1760x440x710	580
CNSA (CNSGA) 38-132		132		30		1890x440x710	620
CNSA (CNSGA) 38-154		154		30		1960x440x710	645
CNSA (CNSGA) 38-176		176		30		2030x440x710	685
CNSA (CNSGA) 38-198		198		37		2140x440x710	750
CNSA (CNSGA) 38-220		220		45		2220x440x710	800
CNSA (CNSGA) 60-66	60	66	3000	22	4.5 (for CNS pumps)	1570x520x730	490
CNSA (CNSGA) 60-99		99		30		1690x520x730	530
CNSA (CNSGA) 60-132		132		45		1850x520x730	640
CNSA (CNSGA) 60-165		165		55		1990x660x790	780

OVERALL DIMENSION & TECHNICAL PARAMETERS

unit model	capacity, m ³ /h	head, m	rotation speed, rpm	electric motor power, kW	net positive suction head, m	overall dimensions L x B x H, mm	weight, kg
CNSA (CNSGA) 60-198	60	198	3000	55	4.5 (for CNS pumps)	2070x520x730	805
CNSA (CNSGA) 60-231		231		75		2320x800x800	1080
CNSA (CNSGA) 60-264		264		75		2400x800x800	1100
CNSA (CNSGA) 60-297		297		75		2480x800x800	1130
CNSA (CNSGA) 60-330		330		110		2630x880x930	1440
CNSA (CNSGA) 105-98	105	98	3000	55	5.5 (for CNS pumps)	2000x640x960	1080
CNSA (CNSGA) 105-147		147		75		2220x840x920	1310
CNSA (CNSGA) 105-196		196		110		2385x885x950	1610
CNSA (CNSGA) 105-245		245		132		2600x950x910	1830
CNSA (CNSGA) 105-294		294		160		2700x950x910	1970
CNSA (CNSGA) 105-343		343		160		2790x950x910	2030
CNSA (CNSGA) 105-392		392		200		2960x950x910	2160
CNSA (CNSGA) 105-441		441		250		3030x1020x970	2510
CNSA (CNSGA) 105-490		490		250		3120x1020x970	2580
CNSA (CNSGA) 180-85	180	85	1500	75	4.0 (for CNS pumps)	2200x880x990	1470
CNSA (CNSGA) 180-128		128		110		2400x930x1000	1830
CNSA (CNSGA) 180-170		170		132		2600x980x990	2070
CNSA (CNSGA) 180-212		212		160		2700x950x970	2250
CNSA (CNSGA) 180-255		255		200		2870x980x970	2510
CNSA (CNSGA) 180-297		297		250		3270x1200x1280	3670
CNSA (CNSGA) 180-340		340		250		3370x1200x1280	3750
CNSA (CNSGA) 180-383		383		315		3600x1200x1280	4220
CNSA (CNSGA) 180-425		425		315		3710x1200x1280	4340
CNSA (CNSGA) 300-120	300	120	1500	160	4.5 (for CNS pumps)	2670x870x1090	2470
CNSA (CNSGA) 300-180		180		250		3000x870x1110	2790
CNSA (CNSGA) 300-240		240		315		3150x870x1100	3150
CNSA (CNSGA) 300-300		300		400		3290x1320x1560	3920
CNSA (CNSGA) 300-360		360		500		3410x1320x1560	4220
CNSA (CNSGA) 300-420		420		500		3530x1320x1560	4380
CNSA (CNSGA) 300-480		480		630		3750x1320x1560	4810
CNSA (CNSGA) 300-540		540		800		3820x1420x1680	5260
CNSA (CNSGA) 300-600		600		800		3940x1420x1680	5430

OVERALL DIMENSIONS & TECHNICAL PARAMETERS

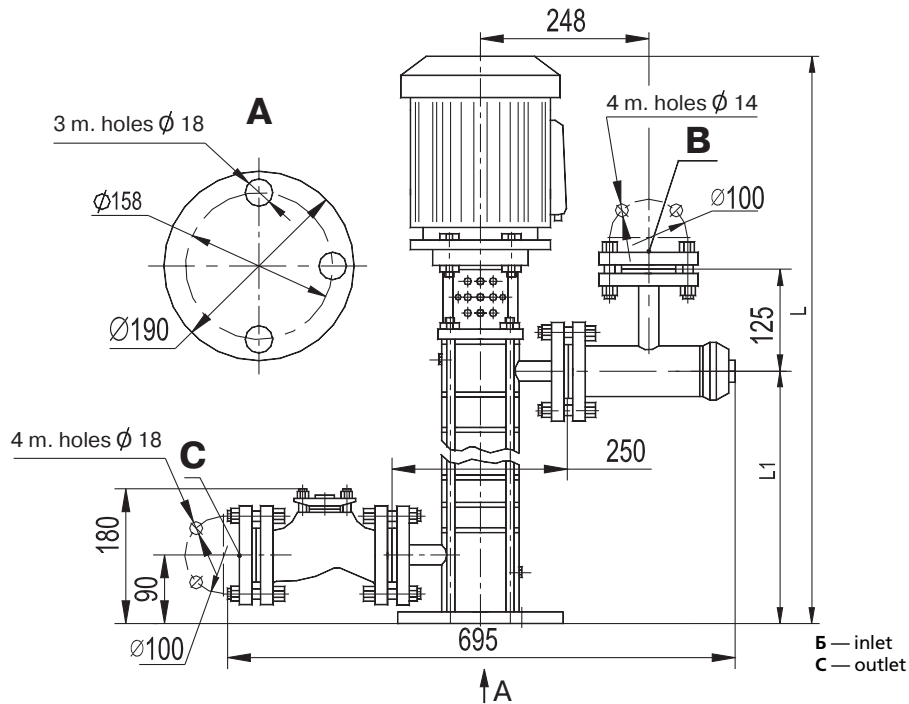

Layout of allowable zones for location of inlet in relation to the outlet

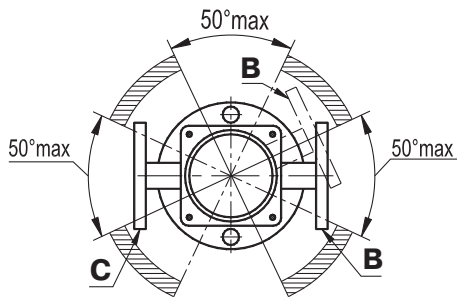

Layout diagram of holes for foundation bolts

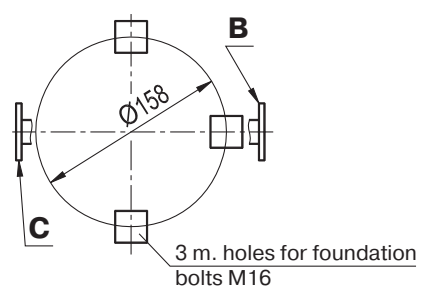

unit model	capacity, m ³ /h	head, m	sync. rotation speed, rpm	net positive suction head, m	operating temp., °C	max inlet pressure, kgf/cm ²	inlet internal diameter, mm	outlet internal diameter, mm	overall dimensions, mm	
									L	L1
ACNS 3-25	3	24	3000	4	105	0.25	32	32	669	228
ACNS 3-36		36							714	273
ACNS 3-45		48							759	318
ACNS 3-60		60							804	363
ACNS 3-75		72							849	409
ACNS 3-85		84							894	453
ACNS 3-100		96							939	498
ACNS 3-108		108							984	543
ACNS 3-120		120							1029	588

OVERALL DIMENSIONS & TECHNICAL PARAMETERS

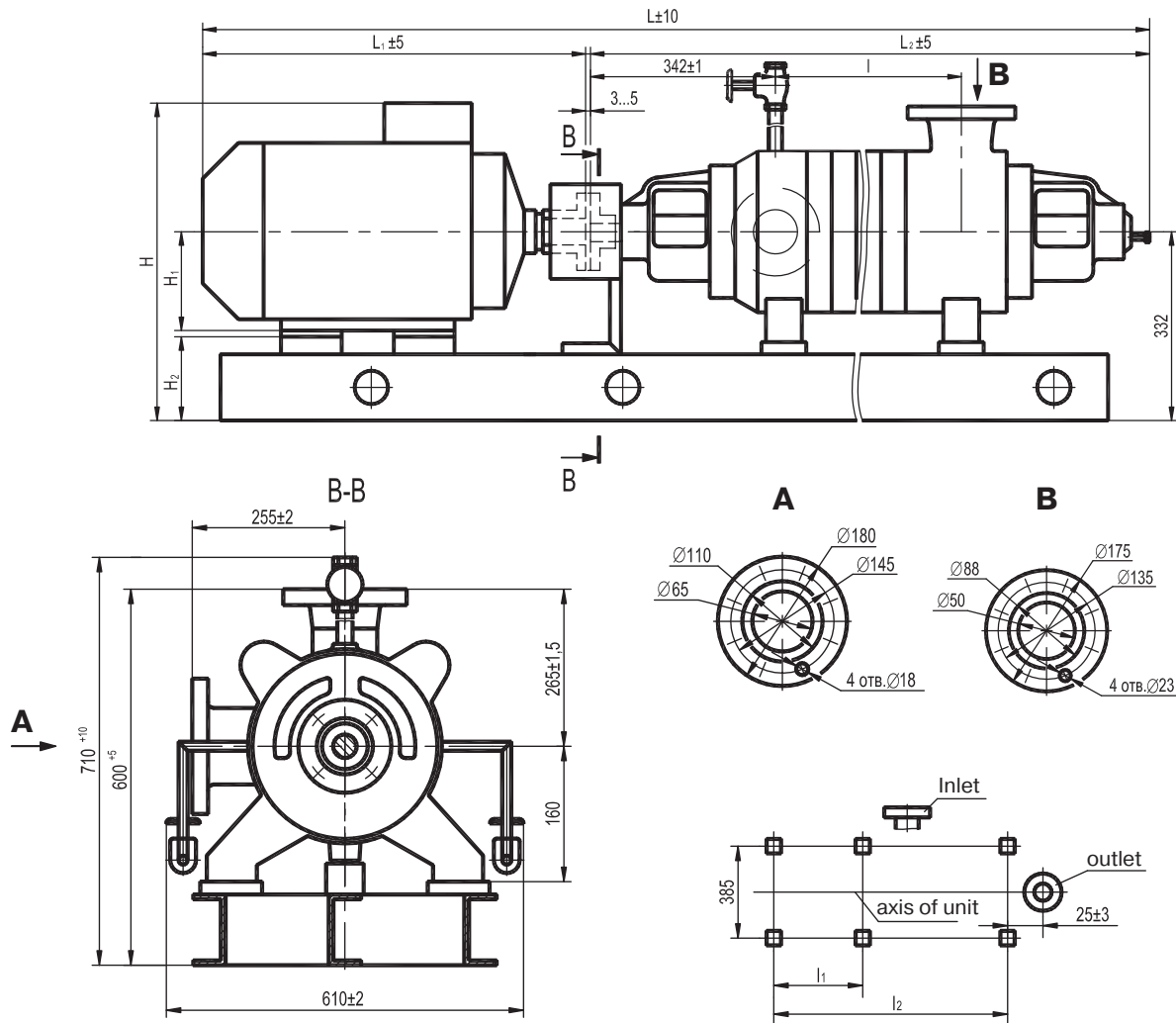

unit model	dimensions in mm									electric motor model	power, kW	weight	
	L	L ₁	L ₂	I	I ₁	I ₂	H	H ₁	H ₂			pump	unit
ACNSg 168-68	1520	505	1011	194	500	960	498	132	198	RA132SB2U3	7.5	240	390
	1620											450	
ACNSg 16-102	1675	605	1064	247	615	1135	560	160	170	RA160MA2U3	11	265	475
ACNSg 16-136	1730											290	510
ACNSg 16-170	1820	645	1170	353	660	1285	575	160	170	AIR160S2U3	15	290	510
ACNSg 16-204	1860											315	550
ACNSg 16-238	1960	680	1276	459	710	1420	590	180	150	AIR180S2U3	22	340	595
ACNSg 16-272	2015											365	640
ACNSg 16-306	1970	580	1382	565	810	1460	620	180	150	AIR180M2U3	30	390	670
ACNSg 16-340	2020											415	690
ACNSg 168-68	1486	440	1011	194	500	930	508	132	198	4AMH180S2U3	37	440	720
	1636											440	720
ACNSg 16-102	1689	620	1064	247	615	1105	530	160	170	AMU160MA2U2	11	265	475
ACNSg 16-136	1742											290	515

OVERALL DIMENSIONS & TECHNICAL PARAMETERS

unit model	dimensions in mm									electric motor model	power, kW	weight	
	L	L ₁	L ₂	I	I ₁	I ₂	H	H ₁	H ₂			pump	unit
ACNSg 16-170	1806	730	1170	353	660	1255	530	160	170	AMU160L2U2	18.5	315	550
ACNSg 16-204	1921		1223	406		1300	570	180	660	200	AMU180M2U2	22	340
ACNSg 16-238	2011		1276	459	1460	810	150	AMU200LA2U2			30	365	690
ACNSg 16-272	2064		1329	512	1520			AMU200LV2U2			37	390	720
ACNSg 16-306	2117		1382	565	1530			AMU200LV2U2			37	415	745
ACNSg 16-340	2170		1435	618	1590	AMU200LV2U2	37	440	775				

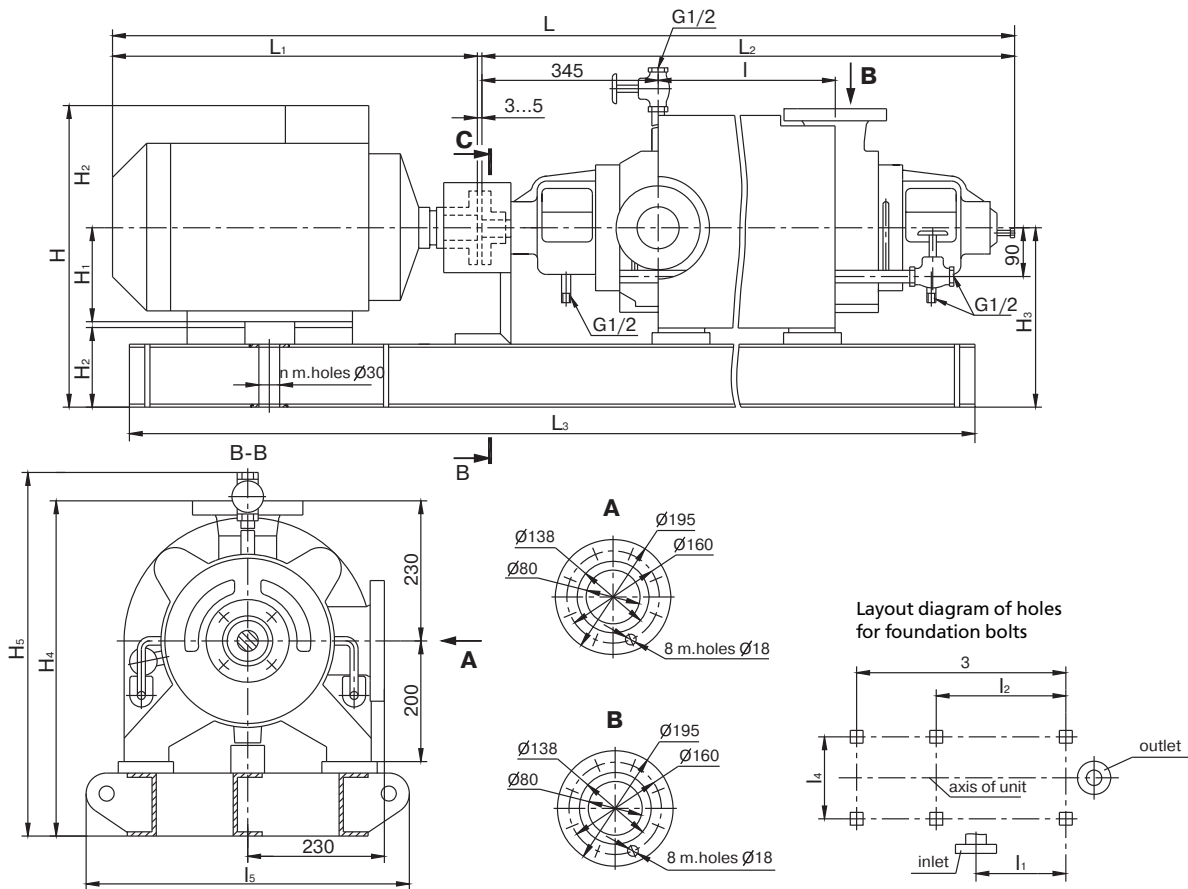

unit model	dimensions in mm															numb. of stages		
	L	L ₁	L ₂	L ₃	I	I ₁	I ₂	I ₃	I ₄	I ₅	H	H ₁	H ₂	H ₃	H ₄		H ₅	
ACNSg 38-44	1380	498	876	1230	195	38		570			561	132	234					
ACNSg 38-66	1615	660	947	1350	266	109	-	720	350	626	567	160	206	366	596	656	4	
ACNSg 38-88	1715	690	1018	1450	337	180		840										
ACNSg 38-110	1725	630	1089	1530	408	248	450	927										
ACNSg 38-132	1845	680	1160	1640	479	319	500	1009	280	510	612	180	170	350	580	640	6	
ACNSg 38-154	1920		1231	1710	550	390	540	1008			612	180	170					
ACNSg 38-176	1990		1302	1780	621	461	570	1151			612	180	170					
ACNSg 38-198	2115		735	1373	1890	692	532	630			1262	637	200					150
ACNSg 38-220	2230		781	1444	2000	763	603	680			1371	637	200					150

OVERALL DIMENSIONS

unit model	dimensions in mm																numb. of stages	
	L	L ₁	L ₂	L ₃	I	I ₁	I ₂	I ₃	I ₄	I ₅	H	H ₁	H ₂	H ₃	H ₄	H ₅		
ACNSg 38-44-01	1710	862	876	1310	195	38		570										3
ACNSg 38-66-01			947	1380	266	109	-	720	350	626	705	160	206	366	596	656		
ACNSg 38-88-01		756	1018	1495	337	180		840										
ACNSg 38-88-01	1945	852	1089	1570	408	248	450	927			719	180	170					7
ACNSg 38-110-01	2075		1160	1715	479	319	500	1009										
ACNSg 38-132-01	2145	908	1231	1785	550	390	540	1080	280	510	739	200	150	350	580	640		
ACNSg 38-176-01	2215		1302	1855	621	461	570	1151										
ACNSg 38-198-01	2330	948	1373	1930	692	532	630	1262										
ACNSg 38-220-01	2430	978	1444	2020	763	603	680	1371			769	225		375	605	665		

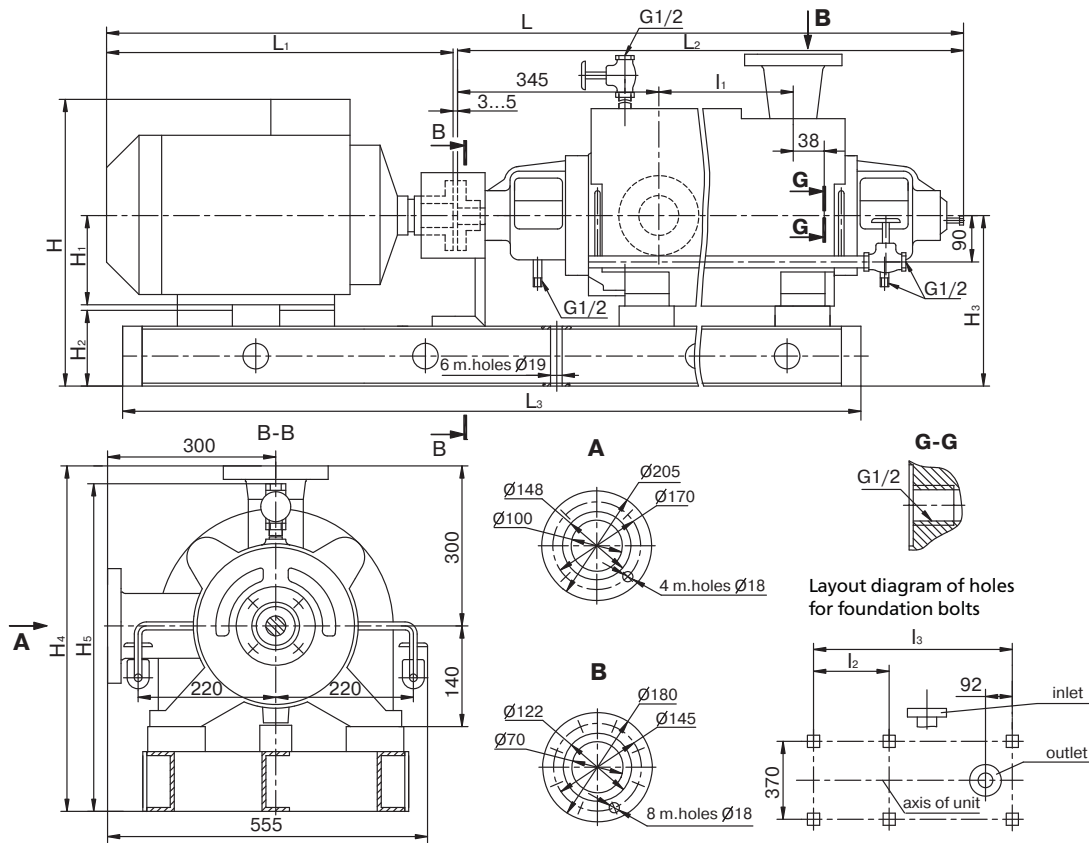

unit model	dimensions in mm												
	L	L ₁	L ₂	L ₃	I ₁	I ₂	I ₃	H	H ₁	H ₂	H ₃	H ₄	H ₅
ACNSgM 38-44	1485	605	880	1205	216	690	1155	555	160	145	307	610	307
ACNSgM 38-66	1555		945	1235	281	655	1185						
ACNSgM 38-88	1645		1010	1335	346		1285	570	180	125	307	307	307
ACNSgM 38-110	1710	630	1075	1400	411		1350						
ACNSgM 38-132	1890		1140	1400	476	690	1415	567	166	307	307	307	307
ACNSgM 38-154	1955	680	1205	1505	541		1480						
ACNSgM 38-176	2150		1270	1570	606		1545	702	225	115	352	652	942
ACNSgM 38-198	2150	810	1335	1795	671	820	1745						
ACNSgM 38-220	2215		1400	1860	736		1810						

OVERALL DIMENSIONS

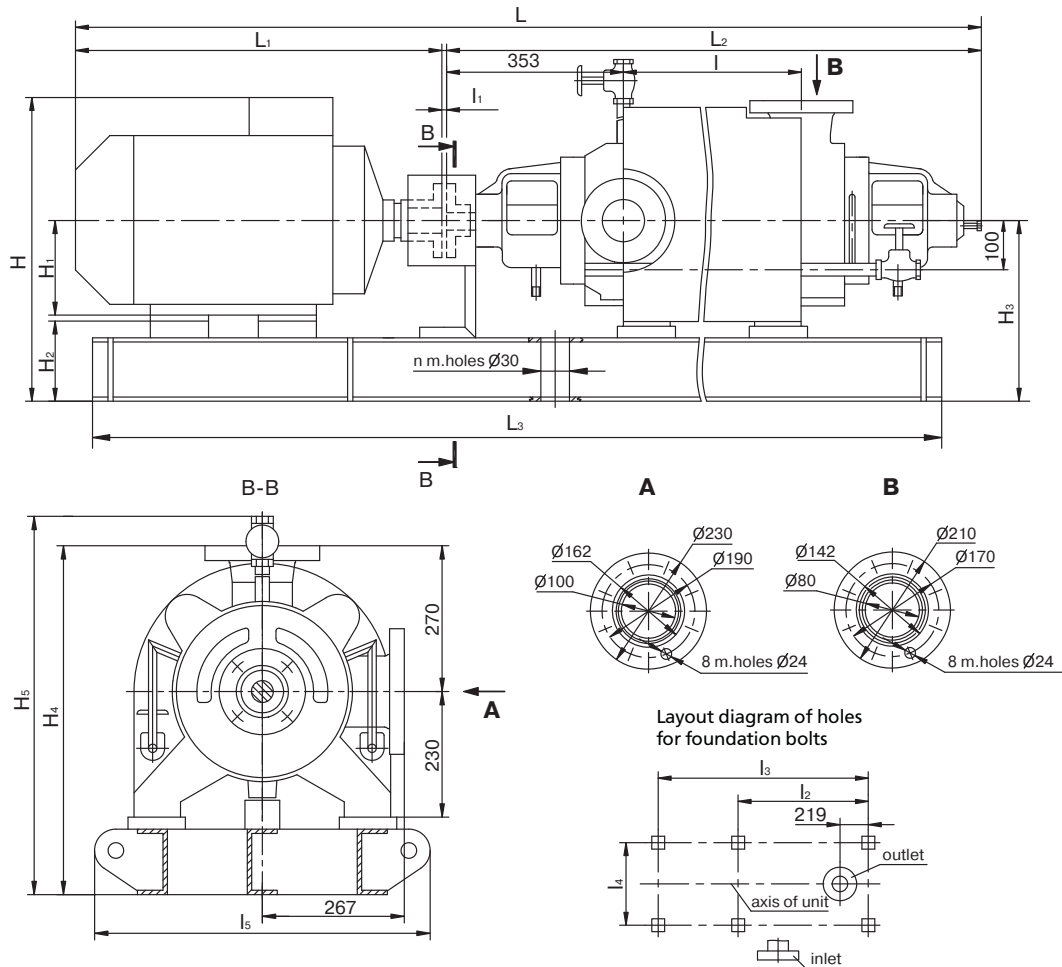

unit model	dimensions in mm															numb. of stages	
	L	L ₁	L ₂	L ₃	l	l ₁	l ₂	l ₃	l ₄	l ₅	H	H ₁	H ₂	H ₃	H ₄		H ₅
ACNSg 60-66	1580	630	945	1295	220	3...5	-	600	406	635	648	180	206	386	655	760	4
ACNSg 60-99	1710	680	1025	1410	300		-	710	406	635	648	180	206	386	655	760	4
ACNSg 60-132	1895	781	1105	1570	380	7...9	350	920	430	660	667	200	180	380	650	755	6
ACNSg 60-165	2030	835	1185	1670	460		450	970		692	225	155	380		650	755	
ACNSg 60-198	2110		1265	1750	540	500	1050	7...9	590	1190	782	250	150	400	670	775	6
ACNSg 60-231	2290	935	1345	1930	620	670	1265		406	635		782	250	150	400	670	
ACNSg 60-264	2370	935	1425	2010	700	700	1350	406	635	782	250	150	400	670	775	6	
ACNSg 60-297	2450		1505	2130	780	700	1350		406	635	782	250	150	400	670		775
ACNSg 60-330	2675	1080	1585	2250	860	7...9	800	1465	457	685	822	280	160	440	710	815	6
ACNSg 60-66-01	1690	738	945	1335	220		-	600	403	635	753	180	206	386	655	760	
ACNSg 60-99-01	1820	792	1025	1490	300	3...5	270	840	430	660	765	200	180	380	650	755	8
ACNSg 60-132-01	1975	862	1105	1590	380		350	890		430	660	700	225		155	380	
ACNSg 60-165-01	2235	1050	1185	1850	460	7...9	450	1115	457	685	820	280	160	440	710	815	8
ACNSg 60-198-01	2315		1265	1930	540		500	1165		457	685	820	280	160	440	710	
ACNSg 60-231-01	2390	1040	1345	1930	620	7...9	590	1190	406	635	782	250	150	400	670	775	6
ACNSg 60-264-01	2470		1425	2010	700		670	1265		406	635	782	250	150	400	670	
ACNSg 60-297-01	2600	1090	1505	2130	780	7...9	700	1350	406	635	782	250	150	400	670	775	6
ACNSg 60-330-01	2700	1110	1585	2250	860		800	1465		457	685	837	280	160	440	710	

OVERALL DIMENSIONS

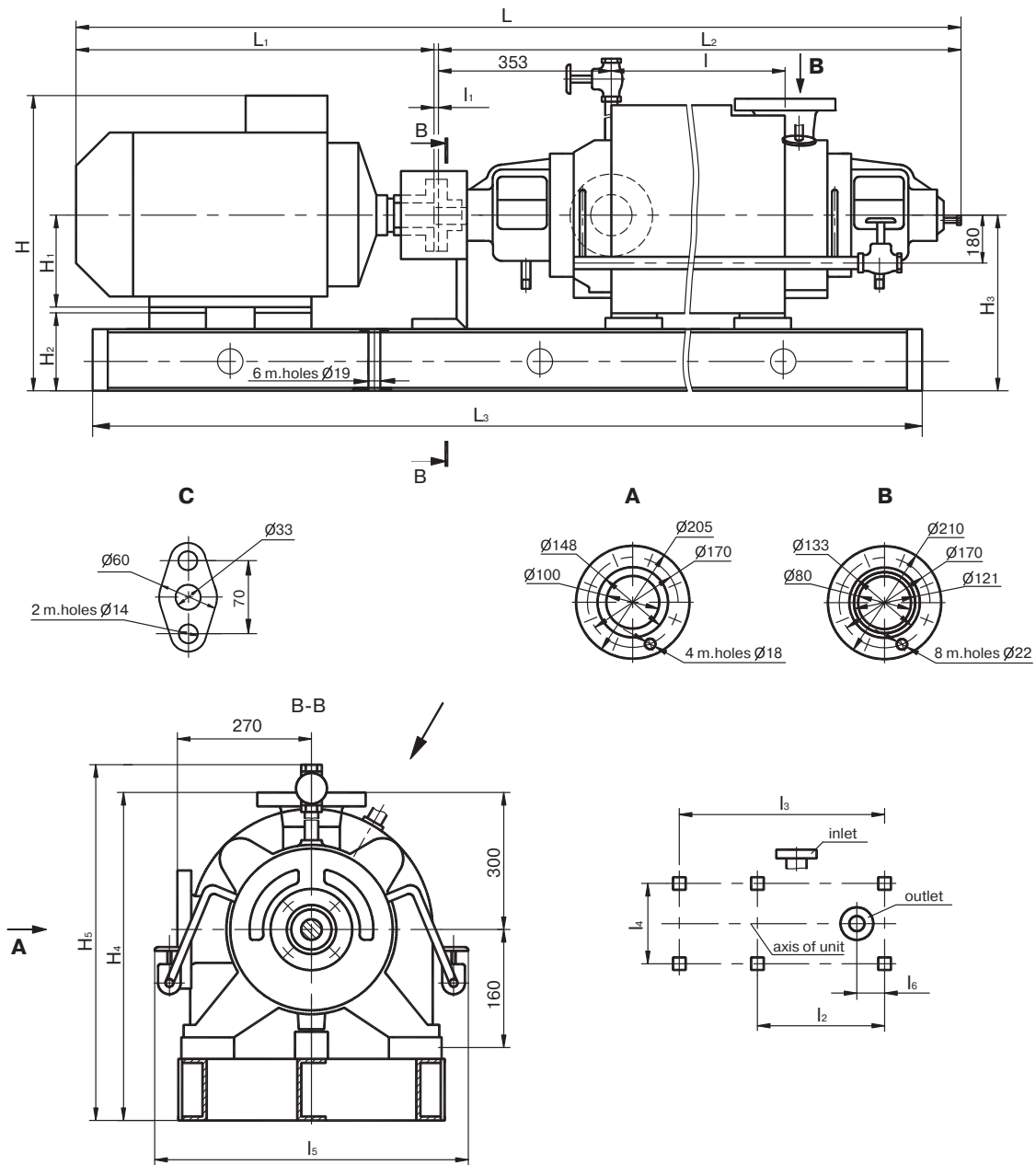

unit model	dimensions in mm																
	L	L ₁	L ₂	L ₃	I	I ₁	I ₂	I ₃	I ₄	I ₅	I ₆	H	H ₁	H ₂	H ₃	H ₄	H ₅
ACNSgM 60-66	1605	630	971	1340	242	3..5	590	1290	450	660	135	590	180	150	330	630	706
ACNSgM 60-99	1735	680	1051	1460	322		710	1410				707	225	132	360	660	736
ACNSgM 60-132	1945	810	1131	1640	402	6..9	740	1590	490	660	135	707	225	132	360	660	736
ACNSgM 60-165	2025	810	1211	1720	482		820	1670				805	250	165	418	718	798
ACNSgM 60-198	2105		1291	1800	562	802	900	1750	490	660	135	805	250	165	418	718	798
ACNSgM 60-231	2290	915	1371	1930	642		980	1880				805	250	165	418	718	798
ACNSgM 60-264	2370		1451	2010	722	882	1060	1960	490	660	135	805	250	165	418	718	798
ACNSgM 60-297	2340	805	1531	2170	802		1140	2040				490	660	135	805	250	165
ACNSgM 60-330	2420	805	1611		882	1220	2120	490	660	135	135				805	250	165

CENTRIFUGAL MULTISTAGE SECTIONAL PUMPS OF CNSv TYPE AND ELECTRIC PUMP UNITS ON THEIR BASIS

APPLICATION

Centrifugal sectional vertical pumps of **CNSv** type and electric pump units on their basis are intended for pumping of water and other non-aggressive liquids with pH = 7-9.2, temperature not more than 120 °C, weight ratio of solid mechanical impurities not more than 0.1%, with the solid particles size not more than 0.1 mm.

Pumps **CNSv** are used for supply of feed water to low and medium power steam boilers, in water booster systems, in industrial systems, and in construction of public and residential buildings for provision of hot and cold water circulation.

Pumps **CNSv** are manufactured in climatic versions UHL and T of location categories 4 and 2 under GOST 15150. The pumps (units) are intended for operation indoors and outdoors under a tent at the ambient air temperature from 0 to +50 °C).

The pumps (units) are not intended for operation in explosion and fire hazardous premises.



PUMP TYPE KEY

Example of designation:
CNSv 20-120-1 UHL4

CNSv XX - XXX - X UHLX

centrifugal sectional vertical pump

capacity, m³/h

head, m

location of nozzles

climatic version and location category

TECHNICAL PARAMETERS												
pump (unit) model	capacity, m ³ /h	head, m	inlet pressure, MPa, (kgf/cm ²), max	rotation speed, s ⁻¹ (rpm)	pump power input, kW	eff., %	number of stages	pump weight, kg	power supply			
									current	voltage, V	freq., Hz	
CNSv12.5-40	12.5	40	0.4(4.0)	49.2(2950)	3.8	55	4	62	alternating	380	50	
CNSv12.5-60	12.5	60			5.2	55	6	74				
CNSv12.5-80	12.5	80			7.6	55	8	86				
CNSv12.5-100	12.5	100			9.5	55	10	98				
CNSv20-45	20	45			5.0	60	4	63				
CNSv20-70	20	70			7.2	60	6	87				
CNSv20-95	20	95			10.2	60	8	111				
CNSv20-120	20	120			13.2	60	10	135				

The values of the major parameters are specified for pumping of water with the temperature of 293K (20 °C) and density 1000 kg/m³

PERFORMANCE CURVE

CNSv 12,5

rotation speed 49.2 s^{-1} (2950 rpm)

liquid – water (20 °C), density 1000 kg/m^3

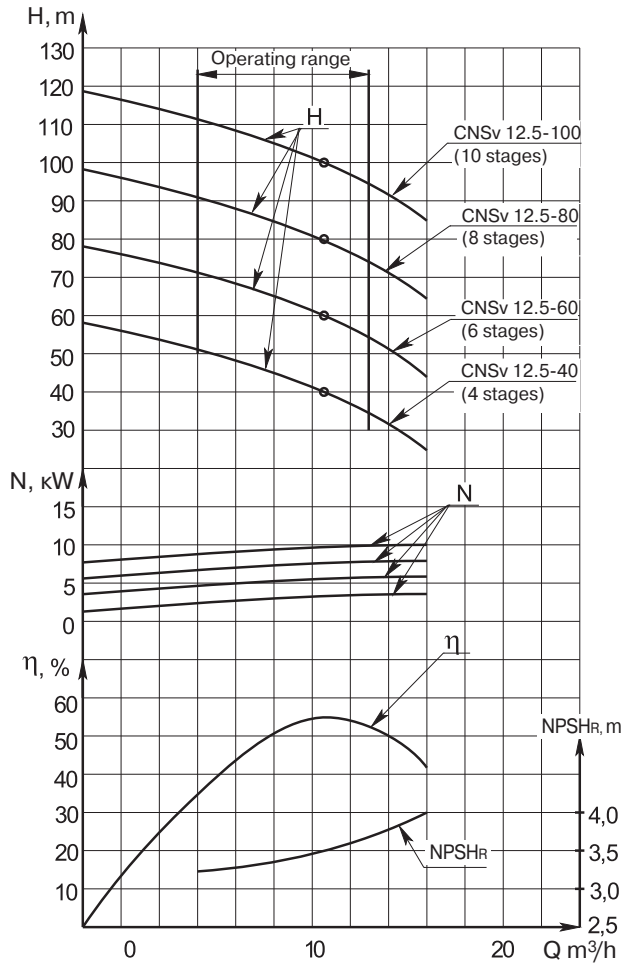

CNSv 20

rotation speed 49.2 s^{-1} (2950 rpm)

liquid – water (20 °C), density 1000 kg/m^3

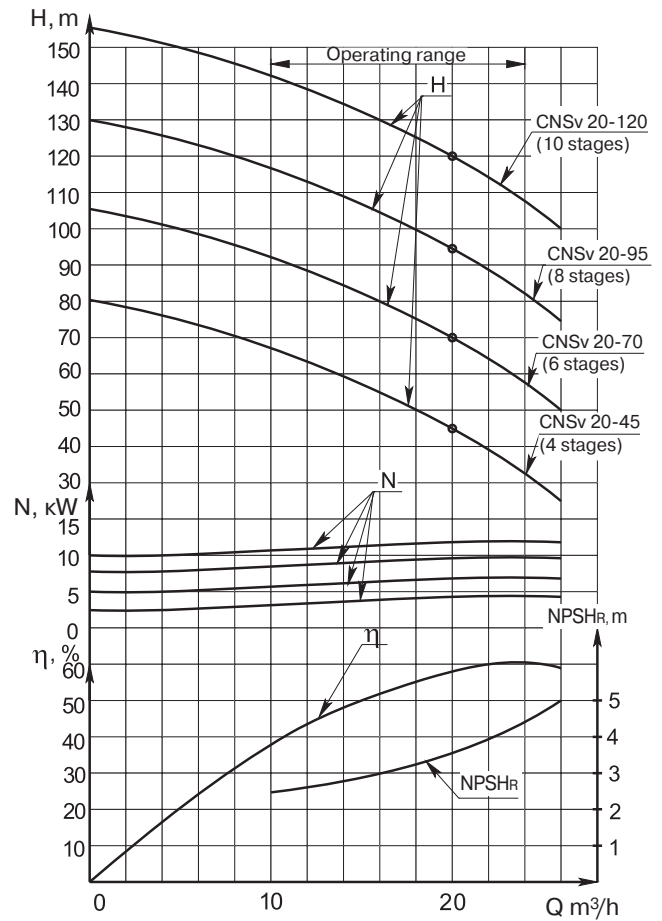

PUMP OVERALL DIMENSIONS

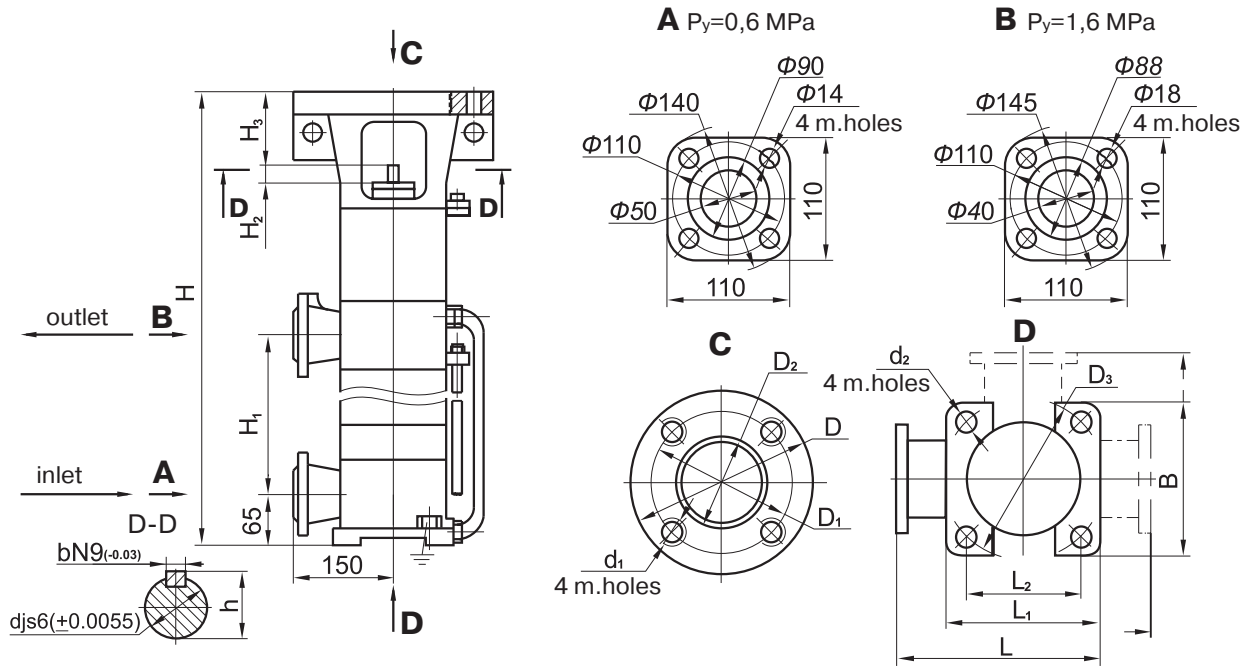

pump model	numb. of stages	nozzles location	dimensions in mm																	weight, kg	
			L	L ₁	L ₂	B	H	H ₁	H ₂	H ₃	D	D ₁	D ₂	D ₃	h	d	d ₁	d ₂	b		
CNSv 12.5-40-1	4	1	232			186	715	270													
CNSv 12.5-40-2	4	2	232			243	715	270													
CNSv 12.5-40-3	4	3	300			186	715	270		92	250	215	180								62
CNSv 12.5-40-4	4	4	232			243	715	270													
CNSv 12.5-60-1	6	1	232			186	830	385											M12		
CNSv 12.5-60-2	6	2	232			243	830	385													
CNSv 12.5-60-3	6	3	300			186	830	385			300	265	230								74
CNSv 12.5-60-4	6	4	232			243	830	385													
CNSv 12.5-80-1	8	1	232	164	96	186	945	500	35						186	16.5	14		18	5	
CNSv 12.5-80-2	8	2	232			243	945	500													
CNSv 12.5-80-3	8	3	300			186	945	500		112											86
CNSv 12.5-80-4	8	4	232			243	945	500													
CNSv 12.5-100-1	10	1	232			186	1060	615											M16		
CNSv 12.5-100-2	10	2	232			243	1060	615													
CNSv 12.5-100-3	10	3	300			186	1060	615													98
CNSv 12.5-100-4	10	4	232			243	1060	615													
CNSv 20-45-1	4	1	245			218	780	295													
CNSv 20-45-2	4	2	245			259	780	295													
CNSv 20-45-3	4	3	300			218	780	295		81	250	215	180								63
CNSv 20-45-4	4	4	245			259	780	295													
CNSv 20-70-1	6	1	245			218	900	415											M12		
CNSv 20-70-2	6	2	245			259	900	415													
CNSv 20-70-3	6	3	300			218	900	415													87
CNSv 20-70-4	6	4	245			259	900	415													
CNSv 20-95-1	8	1	245	194	113	218	1020	535	47	111					218	20.5	18		18	6	
CNSv 20-95-2	8	2	245			259	1020	535													
CNSv 20-95-3	8	3	300			218	1020	535													111
CNSv 20-95-4	8	4	245			259	1020	535													
CNSv 20-120-1	10	1	245			218	1140	655											M16		
CNSv 20-120-2	10	2	245			259	1140	655													
CNSv 20-120-3	10	3	300			218	1140	655		141											135
CNSv 20-120-4	10	4	245			259	1140	655													

UNIT OVERALL DIMENSIONS

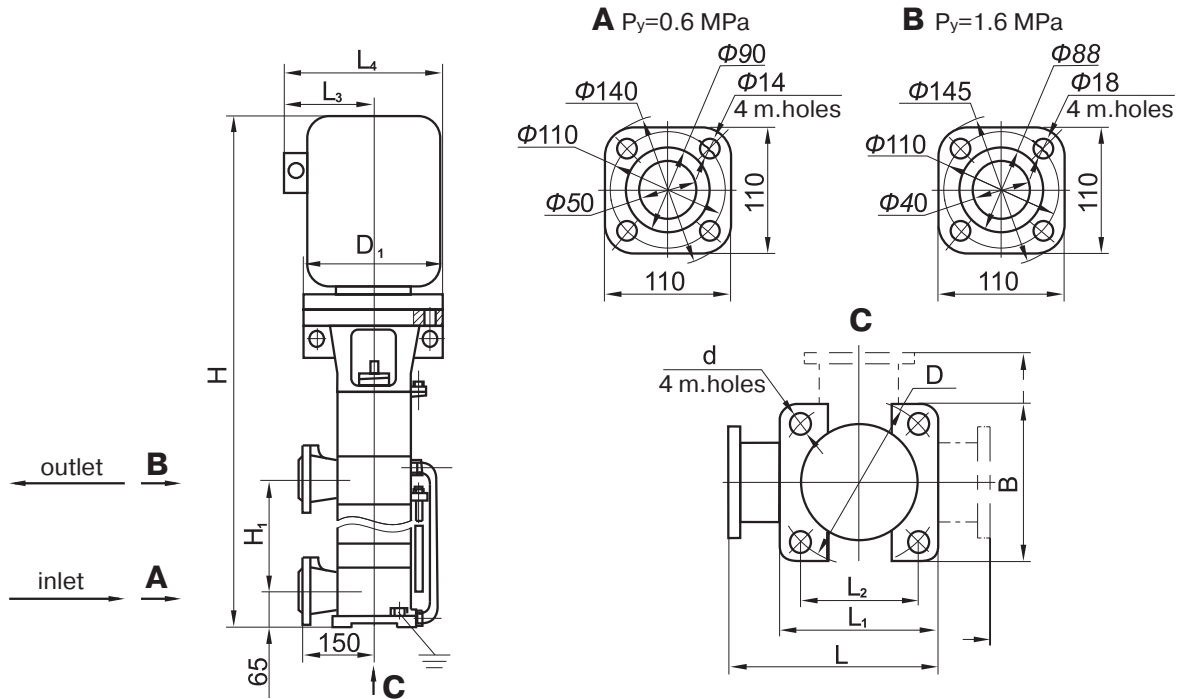

unit model	numb. of stages	electric motor model	el. motor power, kW	dimensions in mm											weight, kg
				L	L ₁	L ₂	L ₃	L ₄	B	D	D ₁	H	H ₁	d	
CNSv 12.5-40-1	4	AIR 100L2	5.5	232	164	96	147	272	186	186	250	1025	270	18	100
CNSv 12.5-40-2	4	AIR 100L2	5.5	232			147	272	243		250	1025	270		100
CNSv 12.5-40-3	4	AIR 100L2	5.5	300			147	272	186		250	1025	270		100
CNSv 12.5-40-4	4	AIR 100L2	5.5	232			147	272	243		250	1025	270		100
CNSv 12.5-60-1	6	AIRM 112M2	7.5	232			173	323	186		300	1185	385		130
CNSv 12.5-60-2	6	AIRM 112M2	7.5	232			173	323	243		300	1185	385		130
CNSv 12.5-60-3	6	AIRM 112M2	7.5	300			173	323	186		300	1185	385		130
CNSv 12.5-60-4	6	AIRM 112M2	7.5	232			173	323	243		300	1185	385		130
CNSv 12.5-80-1	8	AIR 132M2	11	232		193	368	186	350		1365	500	175		
CNSv 12.5-80-2	8	AIR 132M2	11	232		193	368	243	350		1365	500	175		
CNSv 12.5-80-3	8	AIR 132M2	11	300		193	368	186	350		1365	500	175		
CNSv 12.5-80-4	8	AIR 132M2	11	232		193	368	243	350		1365	500	175		
CNSv 12.5-100-1	10	AIR 132M2	11	232		193	368	186	350		1480	615	185		
CNSv 12.5-100-2	10	AIR 132M2	11	232		193	368	243	350		1480	615	185		
CNSv 12.5-100-3	10	AIR 132M2	11	300		193	368	186	350		1480	615	185		
CNSv 12.5-100-4	10	AIR 132M2	11	232		193	368	243	350		1480	615	185		
CNSv 20-45-1	4	AIR 100L2	5.5	245	194	113	147	272	218	218	250	1090	295	18	100
CNSv 20-45-2	4	AIR 100L2	5.5	245			147	272	259		250	1090	295		100
CNSv 20-45-3	4	AIR 100L2	5.5	300			147	272	218		250	1090	295		100
CNSv 20-45-4	4	AIR 100L2	5.5	245			147	272	259		250	1090	295		100
CNSv 20-70-1	6	AIRM 112M2	7.5	245			173	323	218		300	1255	415		145
CNSv 20-70-2	6	AIRM 112M2	7.5	245			173	323	259		300	1255	415		145
CNSv 20-70-3	6	AIRM 112M2	7.5	300			173	323	218		300	1255	415		145
CNSv 20-70-4	6	AIRM 112M2	7.5	245			173	323	259		300	1255	415		145
CNSv 20-95-1	8	AIR 132M2	11	245		193	368	218	350		1440	535	200		
CNSv 20-95-2	8	AIR 132M2	11	245		193	368	259	350		1440	535	200		
CNSv 20-95-3	8	AIR 132M2	11	300		193	368	218	350		1440	535	200		
CNSv 20-95-4	8	AIR 132M2	11	245		193	368	259	350		1440	535	200		
CNSv 20-120-1	10	AIR 160S2	15	245		245	420	218	350		1635	655	265		
CNSv 20-120-2	10	AIR 160S2	15	245		245	420	259	350		1635	655	265		
CNSv 20-120-3	10	AIR 160S2	15	300		245	420	218	350		1635	655	265		
CNSv 20-120-4	10	AIR 160S2	15	245		245	420	259	350		1635	655	265		

CENTRIFUGAL END-SUCTION PUMPS OF 1K TYPE AND ELECTRIC PUMP UNITS ON THEIR BASIS

APPLICATION

Centrifugal end-suction pumps of 1K type and units on their basis are intended for pumping of service water (except for sea water), and also, other liquids similar to water in their density, viscosity, chemical activity, with the temperature from -10 to +105 °C (for pumps 1K50, 1K65 up to +85 °C), pH = 6-9, with solid particles content not more than 1% by weight, with the size not more than 0,2 mm.

Pumps (units) 1K are manufactured in climatic version U3.1 and T2 under GOST 15150-69. Pumps with the shaft end seal are equipped with explosion proof motors and intended for installation in explosion and fire hazardous premises of explosion hazard zone class 1, 2 under GOST R51330.9-99.

The pump and unit general safety requirements comply with GOST R 52743-2007.

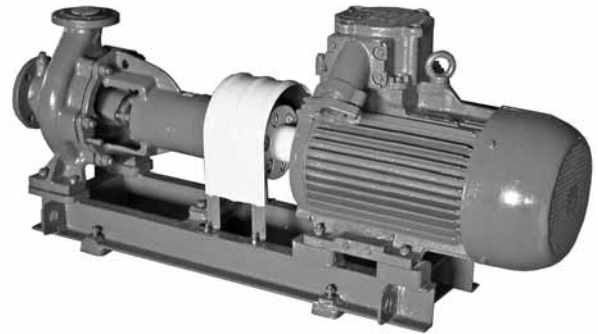

PUMP TYPE KEY

Example of designation:
1K 80-50-200-s(t) U3.1

1K XX - XXX - XX - x U3.1

(upgraded) end-suction

inlet diameter, mm

outlet diameter, mm

impeller nominal diameter, mm

a, b, v – decreased impeller diameter

l, m – increased impeller diameter

shaft sealing: **s** - gland sealing, **t** - end sealing

climatic version and location category

TECHNICAL PARAMETERS					
pump (unit) model	capacity, m ³ /h	head, m	rotation speed, rpm	max. consumed power, kW	net positive suction head, m
1K50-32-125m	12.5	23	2900	1.8	3.5
1K50-32-125	12.5	21	2900	1.6	3.5
1K50-32-125a	12.5	19	2900	1.4	3.5
1K50-32-125b	10	16	2900	1.1	3.5
1K65-50-160	25	32	2900	4.2	3.8
1K65-50-160a	19	31	2900	3.8	3.8
1K65-50-160b	19	25	2900	3	3.8
1K80-65-160m	50	38	2900	11.2	4
1K80-65-160l	50	35	2900	9	4
1K80-65-160	50	32	2900	7	4

TECHNICAL PARAMETERS

pump (unit) model	capacity, m ³ /h	head, m	rotation speed, rpm	max. consumed power, kW	net positive suction head, m
1K80-65-160a	45	30	2900	6	4
1K80-50-200m	65	55	2900	18	3.5
1K80-50-200	50	50	2900	13	3.5
1K80-50-200a	45	45	2900	12	3.5
1K80-50-200b	40	35	2900	8	3.5
1K100-80-160	100	32	2900	12.8	4.5
1K100-80-160m	100	34	2900	14	4.5
1K100-80-160a	90	28	2900	11	4.5
1K100-80-160b	90	25	2900	9	4.5
1K100-80-160v	80	22	2900	9	4.5
1K100-65-200m	100	55	2900	25	4.5
1K100-65-200	100	50	2900	22.5	4.5
1K100-65-200a	90	45	2900	18	4.5
1K100-65-200b	90	40	2900	16	4.5
1K100-65-250m	100	90	2900	47	4.5
1K100-65-250	100	80	2900	37	4.5
1K100-65-250a	80	70	2900	33	4.5
1K100-65-250b	80	60	2900	25	4.5
1K150-125-315m	200	35	1450	35	4
1K150-125-315	200	32	1450	30	4
1K150-125-315a	200	26	1450	22.5	4
1K150-125-315b	170	22	1450	18.5	4

PERFORMANCE CURVE

1K50-32-125

rotation speed 48 s^{-1} (2900 rpm)
liquid – water (20 °C), density 1000 kg/m³

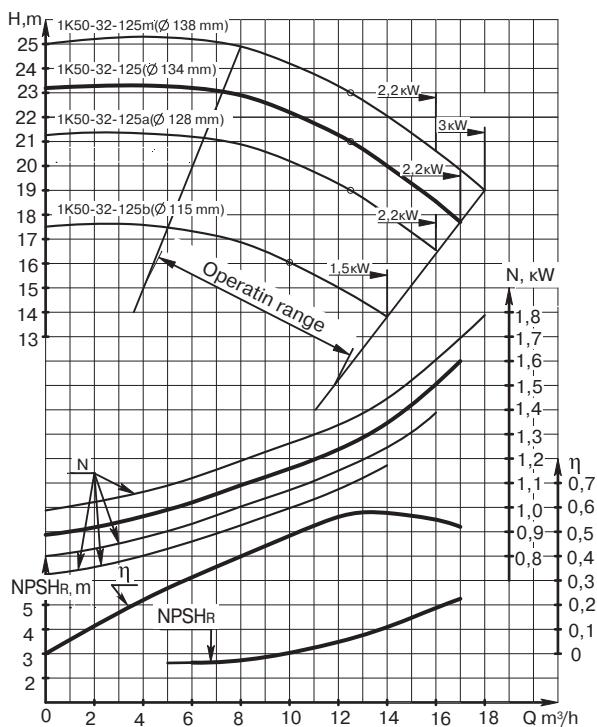

1K65-50-160

rotation speed 48 s^{-1} (2900 rpm)
liquid – water (20 °C), density 1000 kg/m³

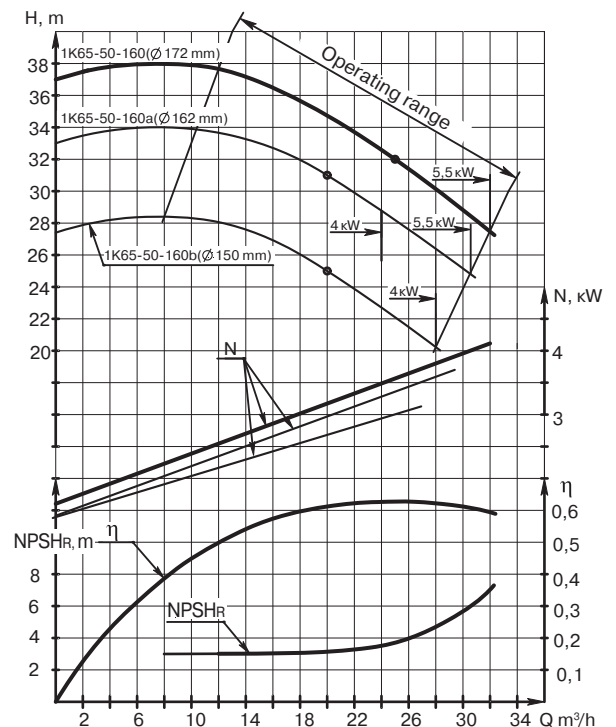

PERFORMANCE CURVE

1K80-65-160

rotation speed 48 s^{-1} (2900 rpm)
liquid – water (20 °C), density 1000 kg/m^3

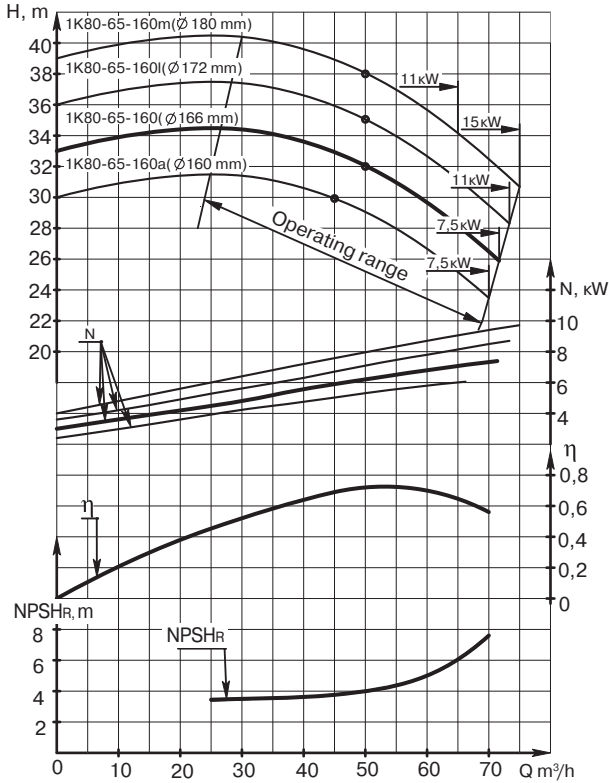

1K80-50-200

rotation speed 48 s^{-1} (2900 rpm)
liquid – water (20 °C), density 1000 kg/m^3

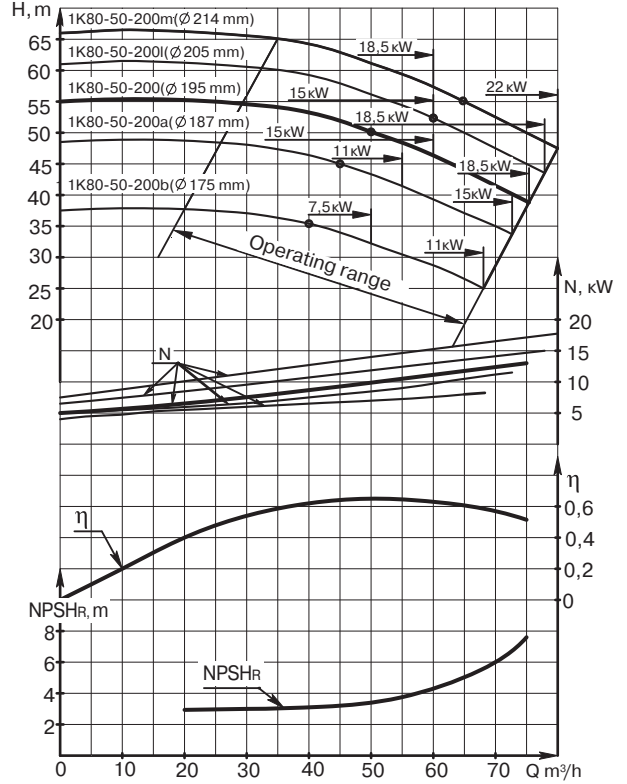

1K100-65-200

rotation speed 48 s^{-1} (2900 rpm)
liquid – water (20 °C), density 1000 kg/m^3

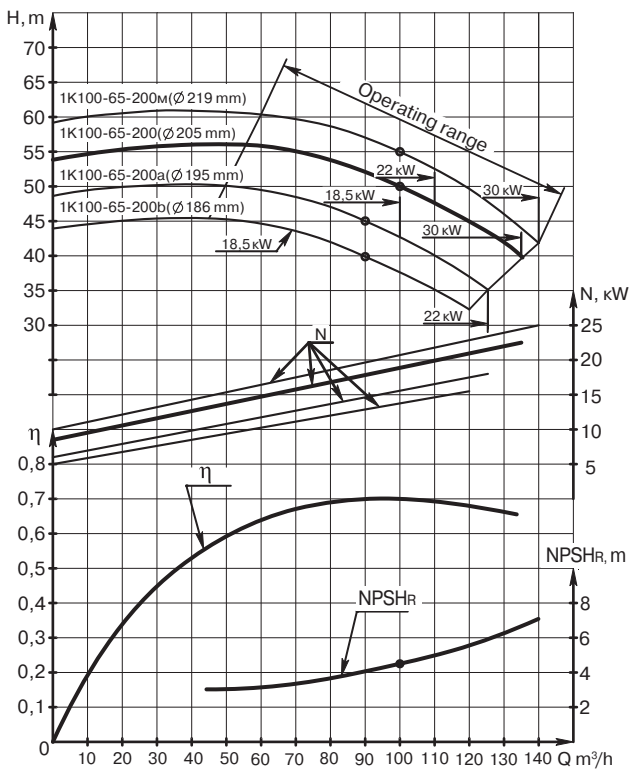

1K100-65-250

rotation speed 48 s^{-1} (2900 rpm)
liquid – water (20 °C), density 1000 kg/m^3

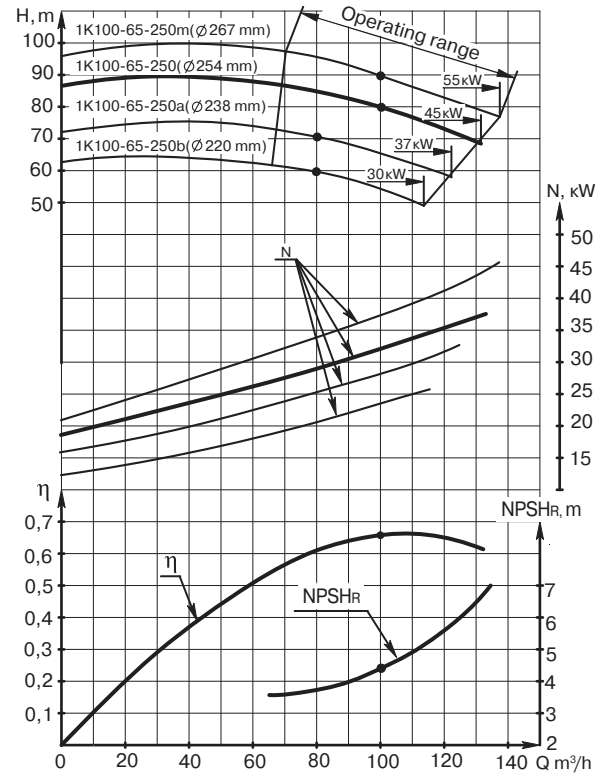

PERFORMANCE CURVE

1K100-80-160

rotation speed 48 s^{-1} (2900 rpm)

liquid – water (20 °C), density 1000 kg/m^3

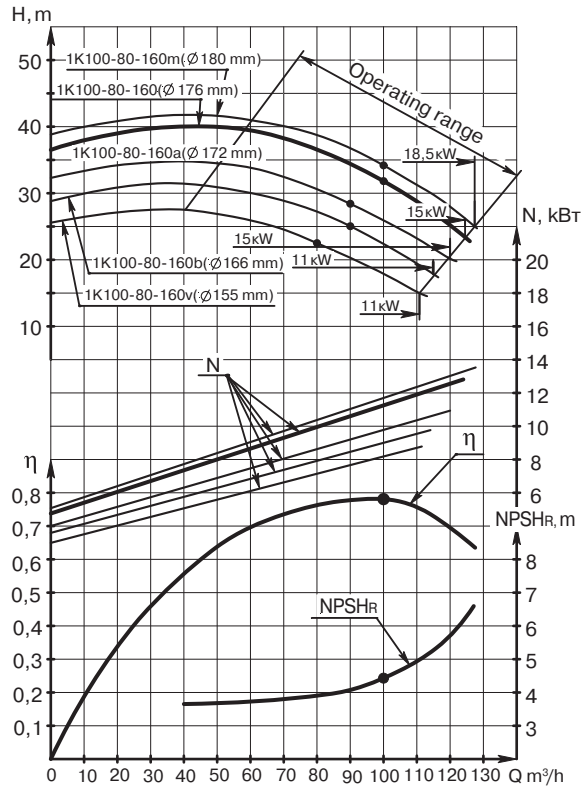

1K150-125-315

rotation speed 24 s^{-1} (1450 rpm)

liquid – water (20 °C), density 1000 kg/m^3

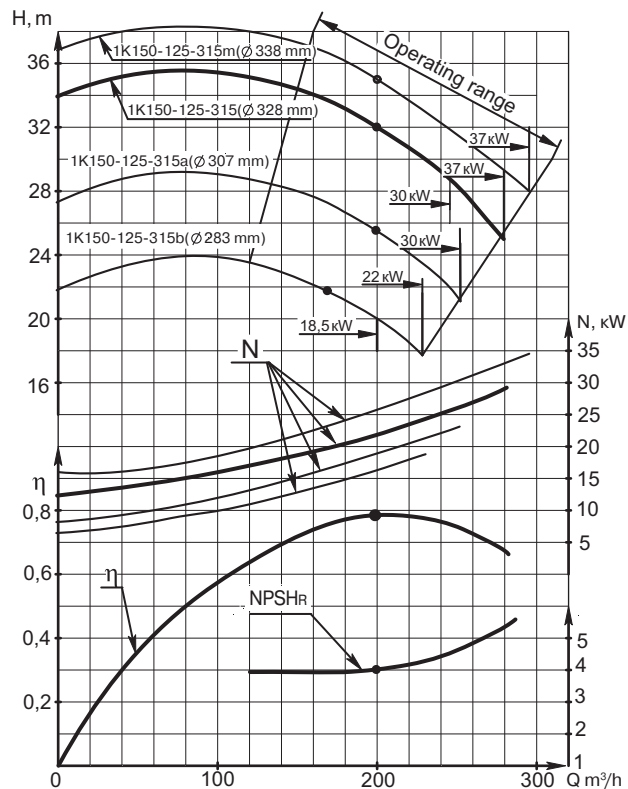

PUMP OVERALL DIMENSIONS

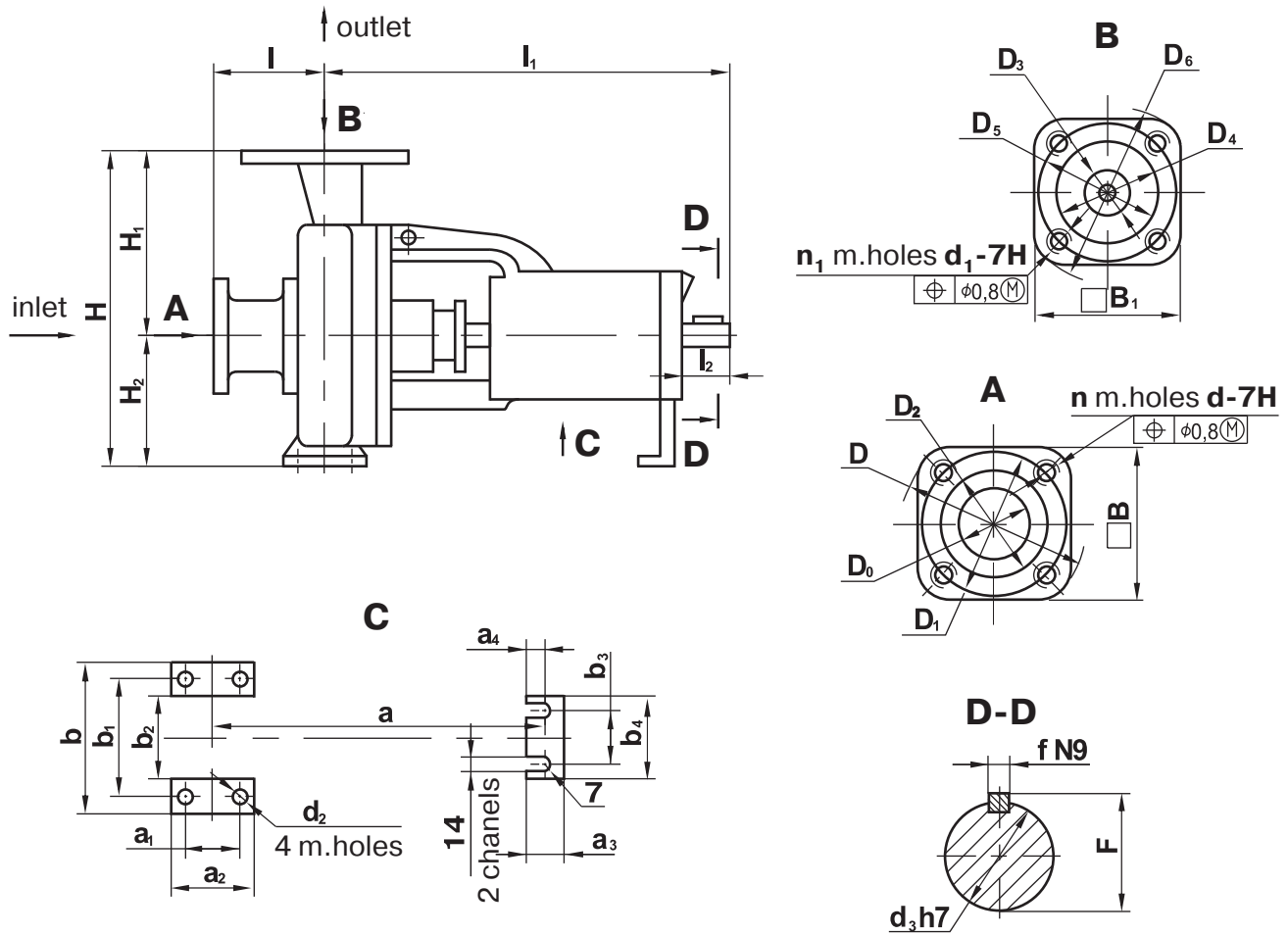

pump model	dimensions in mm															
	I	I ₁	I ₂	a	a ₁	a ₂	a ₃	a ₄	b	b ₁	b ₂	b ₃	b ₄	b ₅	B	B ₁
1K80-50-200	100	385	50	285	70	100	45	16	265	212	165	110	145	14	140	125
1K80-65-160	100	415	80	270	95±0.3	125	45	16	280	212	150	110	145		150	140
1K100-65-250	125	500	80	370	120	160	45	16	360	280	200	110	145		155	140
1K100-80-160	100	415	80	270	95±0.3	125	45	16	280	212	150	110	145		155	150
1K150-125-315	140	558	80	355	150	200	70	30	500	400	300	110	160		-	-
1K50-32-125	80	385	50	275	70	100	45	16	190	140	90	110	145		-	105
1K65-50-160	80	385	50	275	70	100	45	16	240	190	140	110	145		-	125
1K100-65-200	100	500	80	370	95	125	45	16	320	250	190	110	145		-	-

pump model	D	D ₀	D ₁	D ₂	D ₃	D ₄	D ₅	D ₆	d	d ₁	d ₂	d ₃	H	H ₁	H ₂	n	n ₁	f(N9)	F	weight, kg
1K80-50-200	185	80	150	128	50	102	125	160	M16		14	32	360	200	160	4	10 _(-0.036)		35	58
1K80-65-160	195	80	160	133	65	122	145	180			14		360	200	160				35	60
1K100-65-250	205	100	170	148	65	122	145	180			18		450	250	200				35	90
1K100-80-160	205	100	170	148	80	133	160	195			14		385	225	160				35	61
1K150-125-315	260	150	225	202	125	184	210	245	24	42	635	355	280	8	12 _(-0.043)	45	180			
1K50-32-125	140	50	110	90	32	78	100	135	M12	M16	14	24	252	140	112	4	8 _(-0.036)	27	35	
1K65-50-160	180	65	145	122	50	102	125	160	M16		14	24	292	160	132	4	8 _(-0.036)	27	50	
1K100-65-200	215	100	180	158	65	122	145	180	18	14	32	405	225	180	8	4	10 _(-0.036)	35	78	

UNIT OVERALL DIMENSIONS

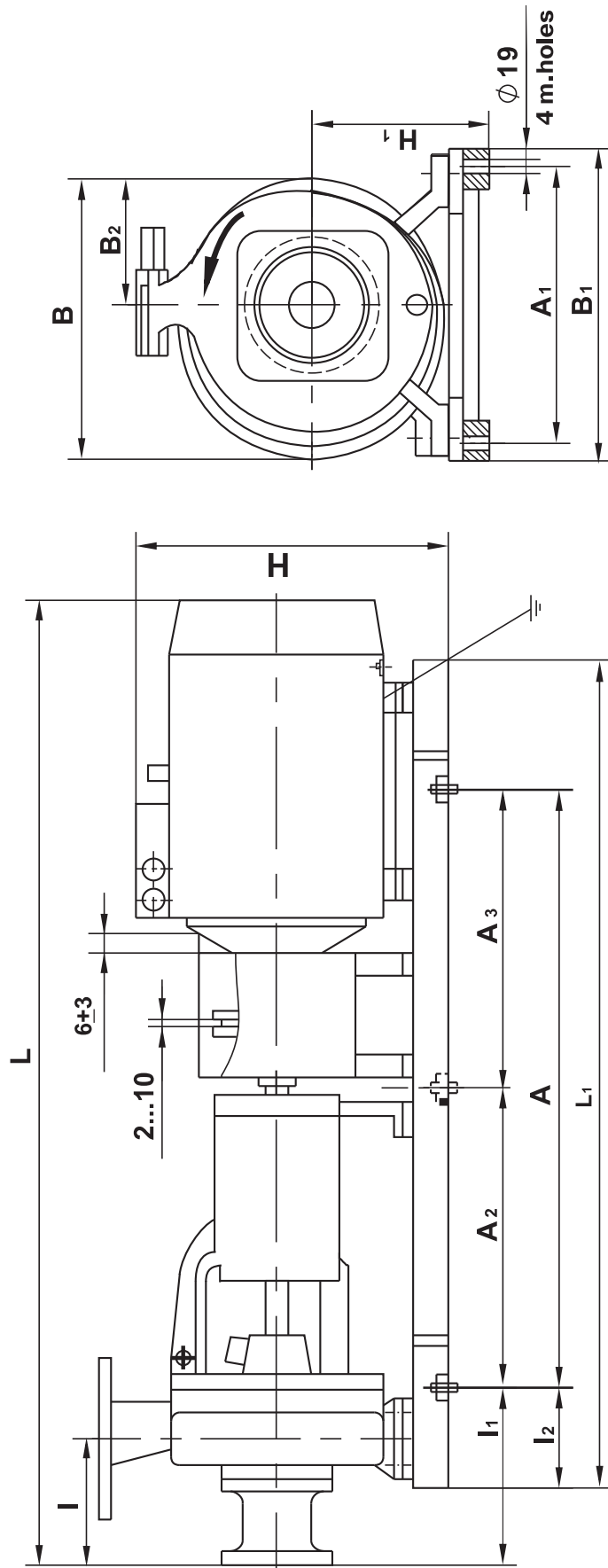

OVERALL DIMENSIONS

unit designation	unit model	max. capacity, m ³ /h	electric motor				dimensions in mm										Weight, kg									
			model	power, kW	rotation speed, s ⁻¹ (rpm)	voltage, V	L	L ₁	I	I ₁	I ₂	A	A ₁	A ₂	A ₃	H		H ₁	B	B ₁	B ₂					
H49.899.00.00.00	1K80-50-200b-s	64	AIRM132M2	11			990													200		188				
	A132M2		995																				200		185	
	AIM132M2		1052				100	173	150															324		237
	VA132M2		990																					200		225
H49.899.00.00.00	1K80-50-200b-s	48	5AM112M2	7.5			970															165				
	A112M2		995																						177	
	AIR112M2		925				100	173	150															324		148
	AIM112M2		990																							188
H49.899.00.00.00	1K80-50-200b-T		VA112M2				985															187				
	5A225M2		1470																						510	
	A225M2		1475																							500
	VA225M2		1475																							541
H49.901.00.00.00	1K100-65-250m-s	140	5AN200M2	55	50 (3000)		1355															420				
	5A200L2		1416																						426	
	A200L2		1440																							425
	BA200L2		1440				1200																			486
H49.901.00.00.00	1K100-65-250-T		4AMH180M2	45			1255															351				
	5A200M2		1370																						405	
	A200M2		1440																							401
	VA200M2		1440																							465
H49.901.00.00.00	1K100-65-250a-s	120	4AMN180S2	37			1215															336				
	AIR180M2		1315																						346	
	A180M2		1340				1150																			336
	VA180M2		1365																							387
H49.908.00.00.00	1K150-125-315m-s	296	5A200M4	37	25 (1500)		1470															530				
	A200M4		1455																						514	
	VA200M4		1500																							580
	4AMH180M4		1325				1197																			490
H49.908.00.00.00	1K150-125-315-T	280	5A200M4	37			1470															530				
	A200M4		1455																						514	
	VA200M4		1500																							580
	4AMH180M4		1325				1197																			490

OVERALL DIMENSIONS

unit designation	unit model	max. capacity, m ³ /h	electric motor				dimensions in mm										Weight, kg						
			model	power, kW	rotation speed, s ⁻¹ (rpm)	voltage, V	L	L ₁	I	I ₁	I ₂	A	A ₁	A ₂	A ₃	H		H ₁	B	B ₁	B ₂		
H49,908.00.00.000	1K150-125-315-s 1K150-125-315-T	245	AIR180M4	30	25 (1500)	220. 380	1410	1197	140	175	150	900	400±1.1	450±1.1	700	435	491	496	272	490			
			A180M4				1385								680						272	490	
			4AMH180S4				1285								730						272	470	
			VA180M4				1460								780						305	534	
	1K150-125-315a-s 1K150-125-315a-T	250	30	AIR180M4	30	25 (1500)	220. 380	1410	1197	140	175	150	900	400±1.1	450±1.1	700	435	491	496	272	490		
				A180M4				1385								680						272	490
				4AMH180S4				1285								730						272	470
				VA180M4				1460								780						305	534
	1K150-125-315b-s 1K150-125-315b-T	230	22	AIR180S4	22	25 (1500)	220. 380	1335	1162	140	175	150	900	400±1.1	450±1.1	700	435	491	496	272	470		
				A180S4				1350								680						272	457
				VA180S4				1345								780						305	505
				AIR160M4				1350								680						272	442
1K150-125-315b-s 1K150-125-315b-T	200	18.5	AIR160M4	18.5	25 (1500)	220. 380	1405	1162	140	175	150	900	400±1.1	450±1.1	680	435	491	496	272	440			
			5A160M4				1405								680						272	440	
			VA160M4				1445								795						272	490	
			AIR160S2				1125								540						160	222	
H49,949.00.00.000	1K80-65-160m-s 1K80-65-160m-T	75	AIR160S2	15	25 (1500)	220. 380	1190	975	140	175	150	620±1.1	400±1.1	450±1.1	537	295	334	350	196	232			
			5A160S2				1210								630						210	256	
			AIMR160S2				1125								655						230	252	
	1K80-65-160m-s 1K80-65-160m-T	65	11	A132M2	11	25 (1500)	220. 380	1025	895	100	178	150	600±1.1	400±1.1	490	270	290	270	145	182			
				AIRM132M2				1018							485						145	185	
				AIM132M2				1080							615						157	233	
1K80-65-160l-s 1K80-65-160l-T	70	11	VA132M2	11	25 (1500)	220. 380	1020	895	100	178	150	600±1.1	400±1.1	560	290	324	290	200	208				
			A132M2				1025							490						145	182		
			AIRM132M2				1018							485						145	185		
H49,949.00.00.000	1K80-65-160-s 1K80-65-160-T	65	VA132M2	7.5	25 (1500)	220. 380	1080	825	100	178	150	600±1.1	400±1.1	615	290	270	290	200	208				
			A112M2				1020							560						145	173		
			AIRM132M2				1018							485						145	185		
	1K80-65-160-s 1K80-65-160-T	65	7.5	5AM112M2	7.5	25 (1500)	220. 380	1000	825	100	178	150	600±1.1	400±1.1	470	290	270	290	200	208			
				AIR112M2				953							450						145	161	
				AIM112M2				1020							580						200	184	
VA112M2	1015	525	200	183																			

OVERALL DIMENSIONS

unit designation	unit model	max. capacity, m ³ /h	electric motor				dimensions in mm										Weight, kg						
			model	power, kW	rotation speed, s ⁻¹ (rpm)	voltage, V	L	L ₁	I	I ₁	I ₂	A	A ₁	A ₂	A ₃	H		H ₁	B	B ₁	B ₂		
H49,949,00,00,000	1K80-65-160a-s 1K80-65-160a-T	55	A112M2	7.5			1025	825			600±1.1				470	290	270			145	173		
			5AM112M2				1000								460								
			AIR112M2				953								450							324	
			AIM112M2				1020								580								
H49,956,00,00,000	1K100-80-160m-s 1K100-80-160m-T	128	VA112M2	18.5			1015								525	350	350	350	200	183			
			AIR160M2				1165								540						160	238	
			5A160M2				1220								537						334	196	245
			AIMR160M2				1260								630						210	273	
H49,949,00,00,000	1K100-80-160-s 1K100-80-160-T	125	VA160M2	15			1175	100	178	150	230±1.1				655	350	350	350	230	253			
			AIR160S2				1125								540						160	224	
			5A160S2				1190								537						334	196	234
			AIMR160S2				1220								630						210	258	
H49,949,00,00,000	1K100-80-160a-s 1K100-80-160a-T	120	BA160S2	15	50 (3000)	220. 380	1135	975			620±1.1				655	350	350	350	230	253			
			AIR160S2				1125								540						160	224	
			5A160S2				1190								537						334	196	234
			AIMR160S2				1220								630						210	258	
H49,949,00,00,000	1K100-80-160b-s 1K100-80-160b-T	115	VA160S2	11			1135							655	350	350	350	230	253				
			A132M2				1025							490						155	182		
			AIRM132M2				1018							485						288	155	185	
			AIM132M2				1090							610						290	157	230	
H49,956,00,00,000	1K100-80-160v-s 1K100-80-160v-T	110	VA132M2	11			1030							555	290	290	290	200	205				
			A132M2				1025							490						155	182		
			AIRM132M2				1018							485						288	155	185	
			AIM132M2				1090							610						290	157	230	
H49,956,00,00,000	1K100-65-200m-s 1K100-65-200m-T	140	VA132M2	30			1030							555	290	290	290	200	205				
			AIR180M2				1285							590						195	322		
			A180M2				1310							575						345	175	312	
			VA180M2				1335							670						380	305	363	
H49,956,00,00,000	1K100-65-200-s 1K100-65-200-T	135	AIR180M2	30			1285	1095	100	120	840±1.1	240±1.1	420±1.1	590	365	365	365	195	322				
			A180M2				1310													575	345	175	312
			VA180M2				1335													670	380	305	363
			AIR180M2				1285													590	195	322	

OVERALL DIMENSIONS

unit designation	unit model	max. capacity, m ³ /h	electric motor				dimensions in mm										Weight, kg							
			model	power, kW	rotation speed, s ⁻¹ (rpm)	voltage, V	L	L ₁	I	I ₁	I ₂	A	A ₁	A ₂	A ₃	H		H ₁	B	B ₁	B ₂			
H49,956,00,00,000	1K100-65-200-s	110	AIR180S2	22			1235														195	302		
	A180S2		1250				365														175		289	
	BA180S2		1250				345														305		342	
H49,956,00,00,000	1K100-65-200a-s	125	AIR180S2	22			1235															302		
	A180S2		1250				365																175	289
	BA180S2		1250				345																305	342
H49,956,00,00,000	1K100-65-200a-t	100	5A160M2	18.5			1305															280		
	AIR160M2		1210				365																175	273
	VA160M2		1345				345																260	322
H49,957,00,00,000	1K100-65-200b-s	120	5A160M2	18.5			1305															280		
	AIR160M2		1210				365																175	273
	VA160M2		1345				345																260	322
H49,957,00,00,000	1K65-50-160-s	32	AIR100L2	5.5			892															95		
	AIM100L2		920				345																130	130
	AIR100L2		892				345																130	130
H49,957,00,00,000	1K65-50-160a-s	32	AIM100L2	5.5	50 (3000)	220.	892															95		
	AIR100L2		920				345																130	130
	AIM100L2		892				345																130	130
H49,957,00,00,000	1K65-50-160a-t	24	AIR100S2	4.0			862															89		
	AIM100S2		902				345																130	130
	AIR100S2		862				345																130	130
H49,958,00,00,000	1K50-32-125m-s	18	AIR90L2	3			837															68		
	AIM90L2		860				345																113	113
	AIR80V2		820				345																113	113
H49,958,00,00,000	1K50-32-125m-t	16	AIM80V2	2.2			830															87		
	AIR80V2		820				345																113	113
	AIM80V2		830				345																113	113
H49,958,00,00,000	1K50-32-125a-s	17	AIR80V2	2.2			820															64		
	AIM80V2		830				345																113	113
	AIR80V2		820				345																113	113
H49,958,00,00,000	1K50-32-125a-t	16	AIM80V2	2.2			830															64		
	AIR80V2		820				345																113	113
	AIM80V2		830				345																113	113
H49,958,00,00,000	1K50-32-125b-s	14	AIR80A2	1.5			816															61		
	AIM80A2		830				345																113	113
	AIR80A2		816				345																113	113

CENTRIFUGAL END-SUCTION PUMPS OF K 45/30 TYPE AND ELECTRIC PUMP UNITS ON THEIR BASIS

APPLICATION

Centrifugal end-suction pumps of **K 45/30** type and electric pump units on their basis are intended for pumping of water (except for sea water), and also, other liquids similar to water in their density, viscosity, and chemical activity, with the temperature from -10 to +105 °C (for pumps **1K50**, **1K65** up to +85 °C), pH = 6-9, with solid particles content not more than 1% by weight, with the size not more than 0.2 mm.

The pumps (units) are intended for replacement and repair of similar pumps (pump units) previously manufactured by other plants.

Pumps **K 45/30** are manufactured in climatic version U3.1 under GOST 15150-69.

The pumps (units) are not intended for operation in explosion and fire hazardous premises.

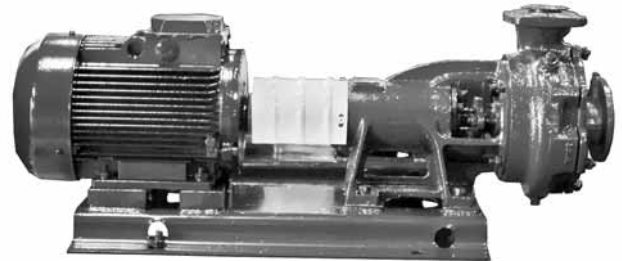

PUMP TYPE KEY

Example of designation:
K 45/30 U3.1

K XX / XX U3.1

end-suction

capacity, m³/h

head, m

climatic version and location category

TECHNICAL PARAMETERS		
parameter	norm	
	K 45/30	K 45/30a
capacity, m ³ /h (l/s)	45 (12.5)	35 (9.7)
head, m	32	25
rotating speed, s ⁻¹ (rpm)	48 (2900)	
pump inlet pressure, MPa (kgf/cm ²), max	0.25 (2.5)	
net positive suction head, m, not more	4.0	
leakage through the gland seal, m ³ /h (l/s)	0.3 - 1.5x10 ⁻³ (0.3 - 1.5)	
pump efficiency, %, min	72	70
pump consumed power, kW	6.5	5.0
pump weight, kg	49.5	
power supply	current	alternating
	voltage, V	220V / 380V
	frequency, Hz	50 Hz

The values of the major parameters are specified for pumping of water with the temperature of 293K (20 °C) and density 1000 kg/m³

PERFORMANCE CURVE

K45/30

rotation speed 48 s^{-1} (2900 rpm)

liquid – water (20 °C), density 1000 kg/m^3

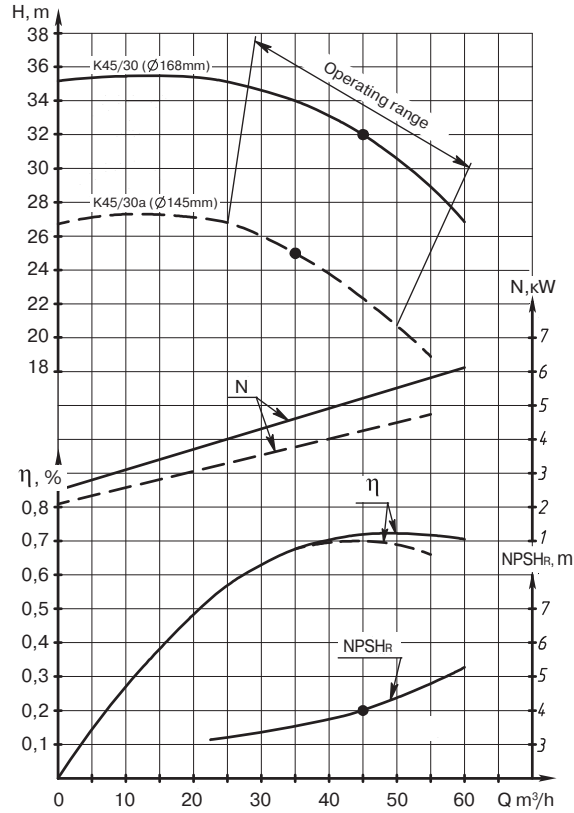

PUMP OVERALL DIMENSIONS

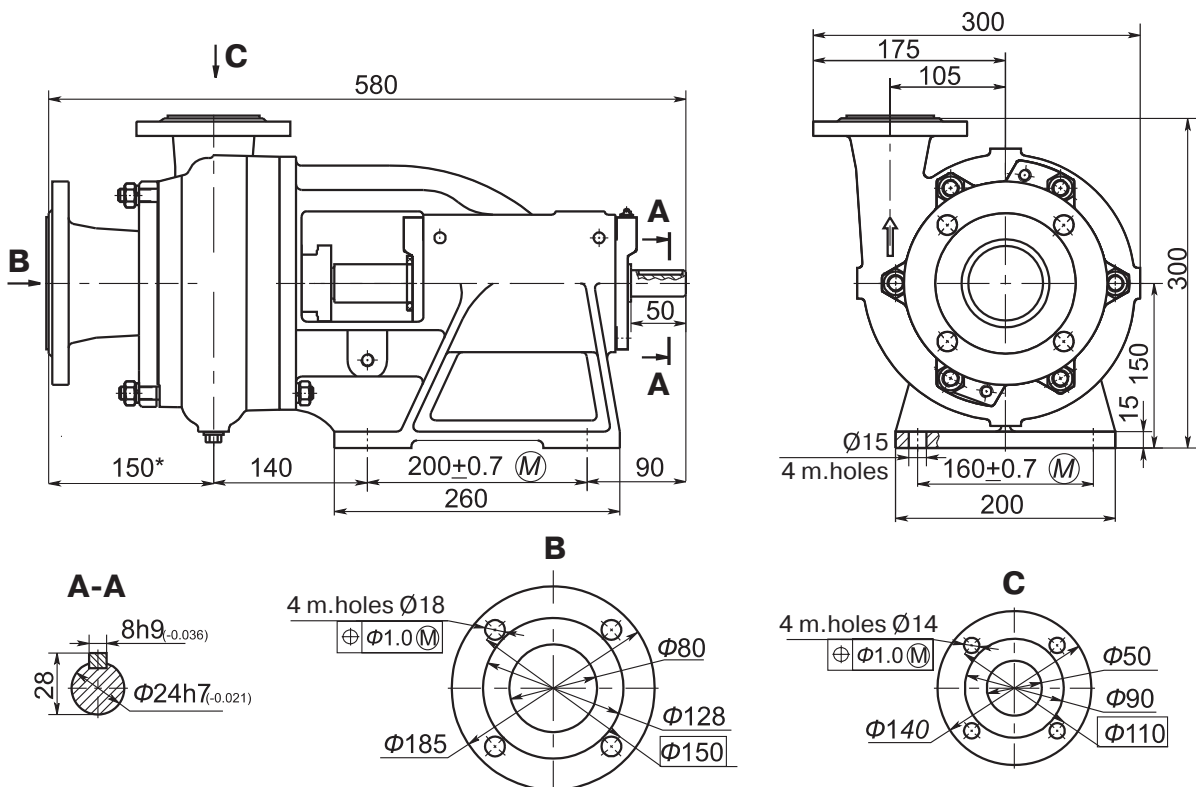

UNIT OVERALL DIMENSIONS

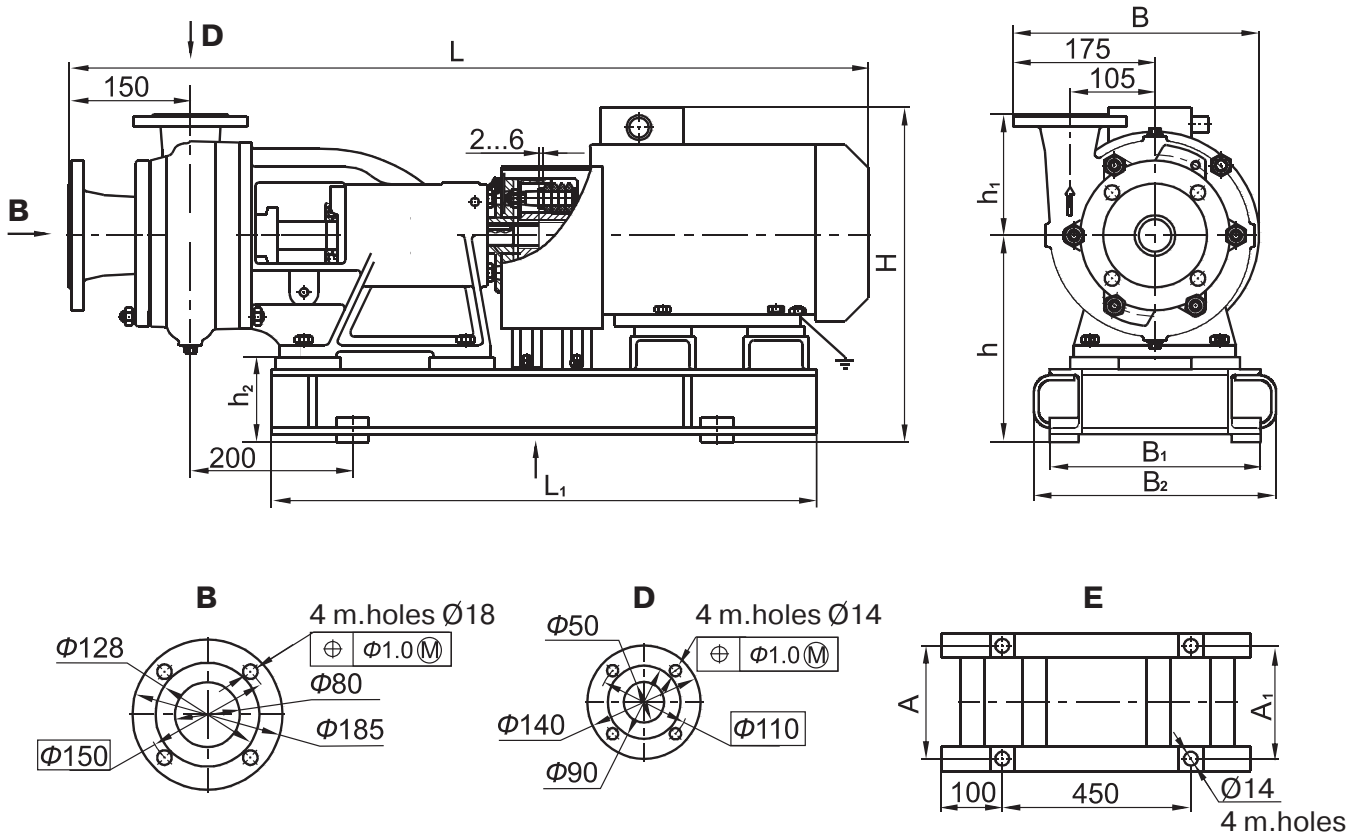

unit model	electric motor		dimensions in mm											weight, kg
	model	power, kW	L	L ₁	A	A ₁	h	h ₁	h ₂	B	B ₁	B ₂	H	
K45/30	AIR112M2U3	7,5	1035	690	225	225	255	150	105	300	260	300	415	118
	5AM112M2U3		1085										425	135
	A112M2U3		1100										455	148
	AIRM112M2U3		1040										428	127
K45/30a	AIR100L2U3	5,5	995	660	250	290-320	215	150	65	300	360	360	405	110
	A100L2U3		1025										435	97
K45/30	AIR112M2U3	7,5	1035	690	250	290-320	215	150	65	300	360	360	375	119
	5AM112M2U3		1085										385	136
	A112M2U3		1100										415	149
	AIRM112M2U3		1040										388	128
K45/30a	AIR100L2U3	5,5	995	665	250	290-320	215	150	65	300	360	360	365	109
	A100L2U3		1025										395	106

CENTRIFUGAL END-SUCTION PUMPS OF 1K 8/18 AND 1K 20/30 TYPE AND ELECTRIC PUMP UNITS ON THEIR BASIS

APPLICATION

Centrifugal end-suction pumps of **1K 8/18**, **1K 20/30** types and electric pump units on their basis are intended for pumping of water (except for sea water), and also, other liquids similar to water in their density, viscosity, and chemical activity, with the temperature from -10 to +105 °C (for pumps **1K50**, **1K65** up to +85 °C), pH=6-9, with solid particles content not more than 1% by weight, with the size not more than 0.2 mm.

The pumps (units) are not intended for operation in explosion and fire hazardous premises.



PUMP TYPE KEY

Example of designation:
1K 8/18a U3.1

upgrade

end-suction

capacity, m³/h

head, m

impeller nominal diameter, mm

m – increased impeller diameter

a, b – decreased impeller diameter

climatic version and location category

1 K XX / XX x U3.1

TECHNICAL PARAMETERS		norm	
parameter	1K 8/18K	1K 20/30	
capacity, m ³ /h (l/s)	8 (2.2)	20 (5.6)	
head, m	18	30	
rotating speed, s ⁻¹ (rpm)	48 (2900)		
pump inlet pressure, MPa (kgf/cm ²), max	0.25 (2.5)		
net positive suction head, m, not more	3.8		
leakage through the gland seal, m ³ /h (l/s)	0.3 - 1.5x10 ⁻³ (0.3 - 1.5)		
pump efficiency, %, min	53	64	
pump consumed power, kW	1.2	3.5	
power supply	current	alternating	
	voltage, V	220V / 380V	
	frequency, Hz	50	

The values of the major parameters are specified for pumping of water with the temperature of 293K (20 °C) and density 1000 kg/m³

PERFORMANCE CURVE

1K8/18

rotation speed 48 s^{-1} (2900 rpm)
liquid – water (20 °C), density 1000 kg/m^3

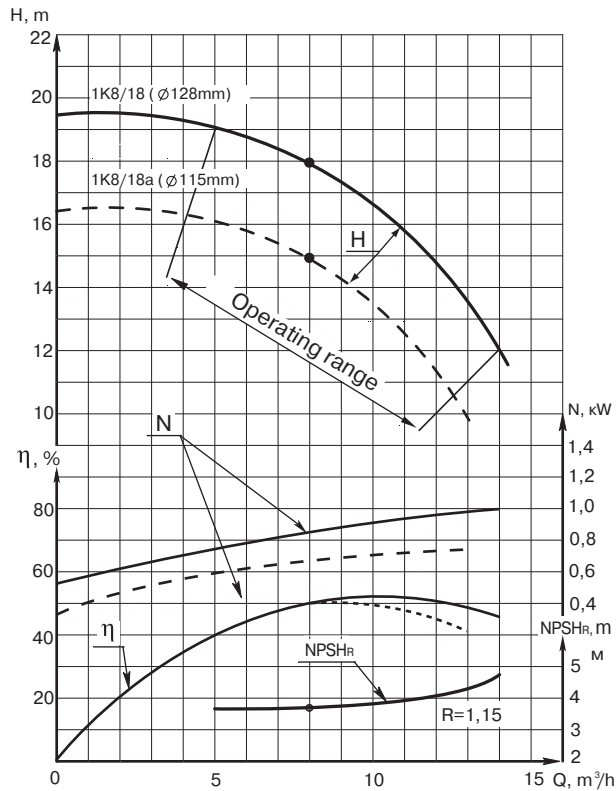

1K20/30

rotation speed 48 s^{-1} (2900 rpm)
liquid – water (20 °C), density 1000 kg/m^3

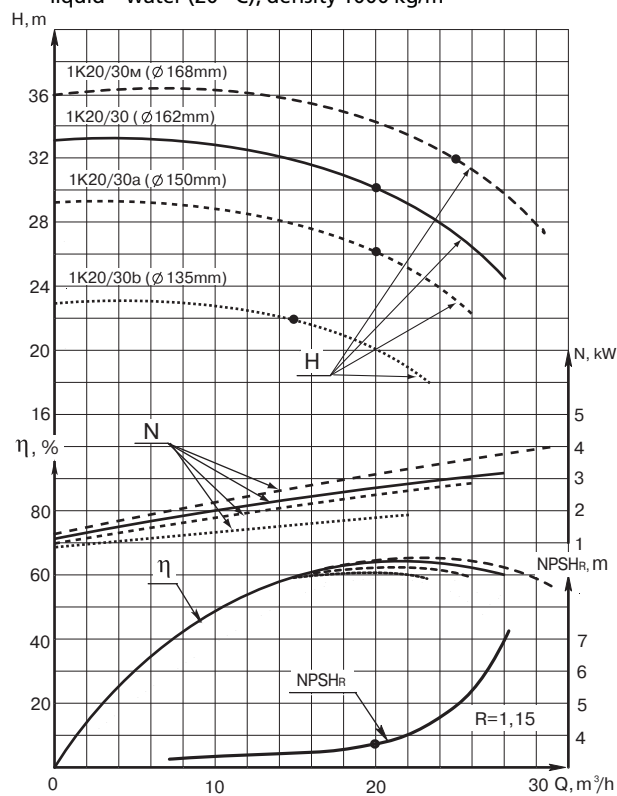

PUMP OVERALL DIMENSIONS

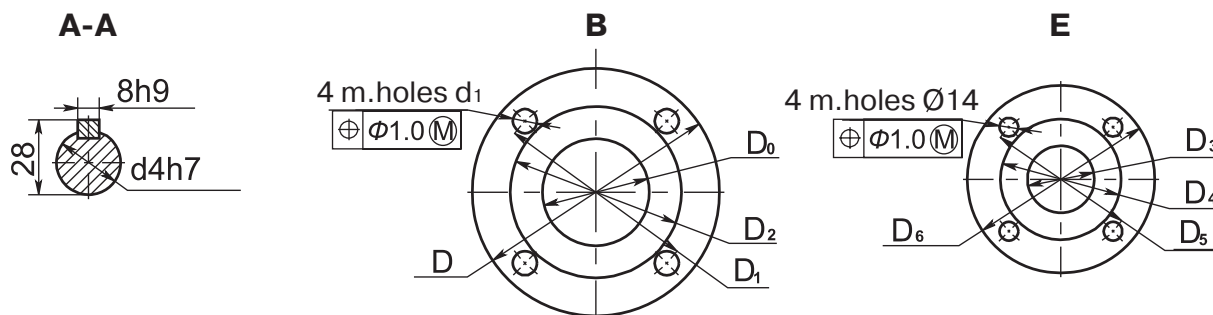
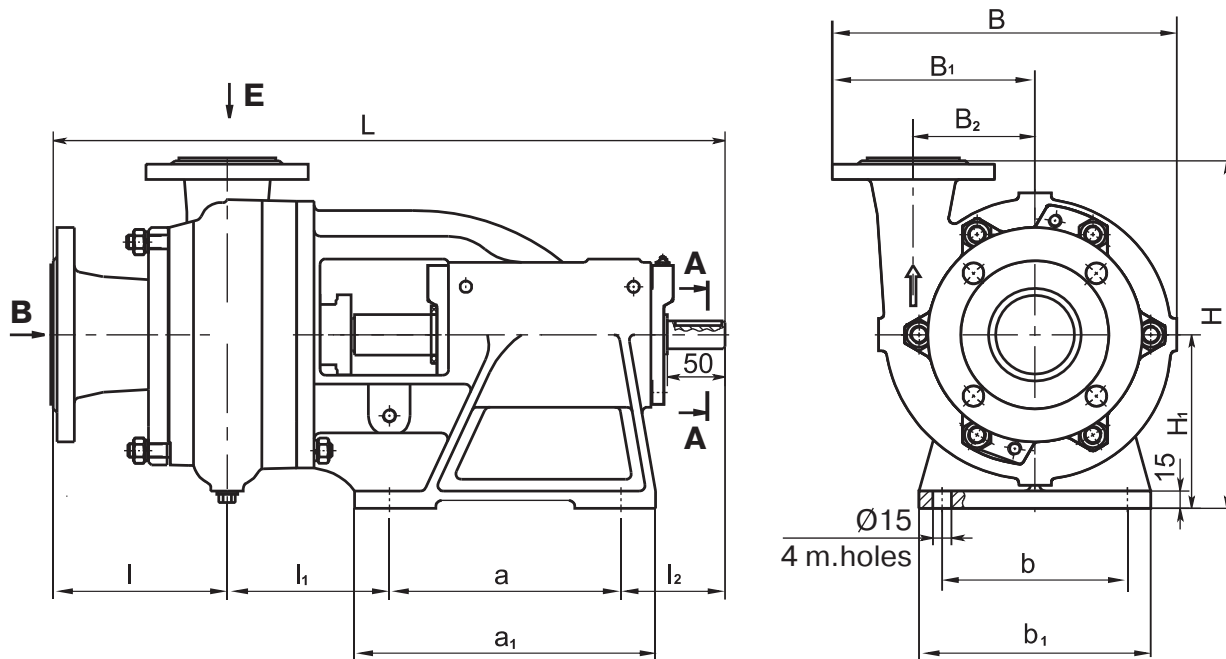

unit model	dimensions in mm												
	L	l	l ₁	l ₂	a	a ₁	b	b ₁	B	B ₁	B ₂	H	H ₁
1K8/18	466	120	115	91	195	140±0.7 M	160	130±0.7 M	230	135	75	240	120
1K20/30	466	120	115	91	195	140±0.7 M	160	130±0.7 M	275	163	98	270	120

unit model	dimensions in mm												weight, kg
	d	d ₁	D	D ₀	D ₁	D ₂	D ₃	D ₄	D ₅	D ₆	D ₇	D ₈	
1K8/18	25	14	140	50	110	90	32	70	90	120	95	110	27
1K20/30	25	14	160	65	130	100	40	80	100	130	100	125	30.5

UNIT OVERALL DIMENSIONS

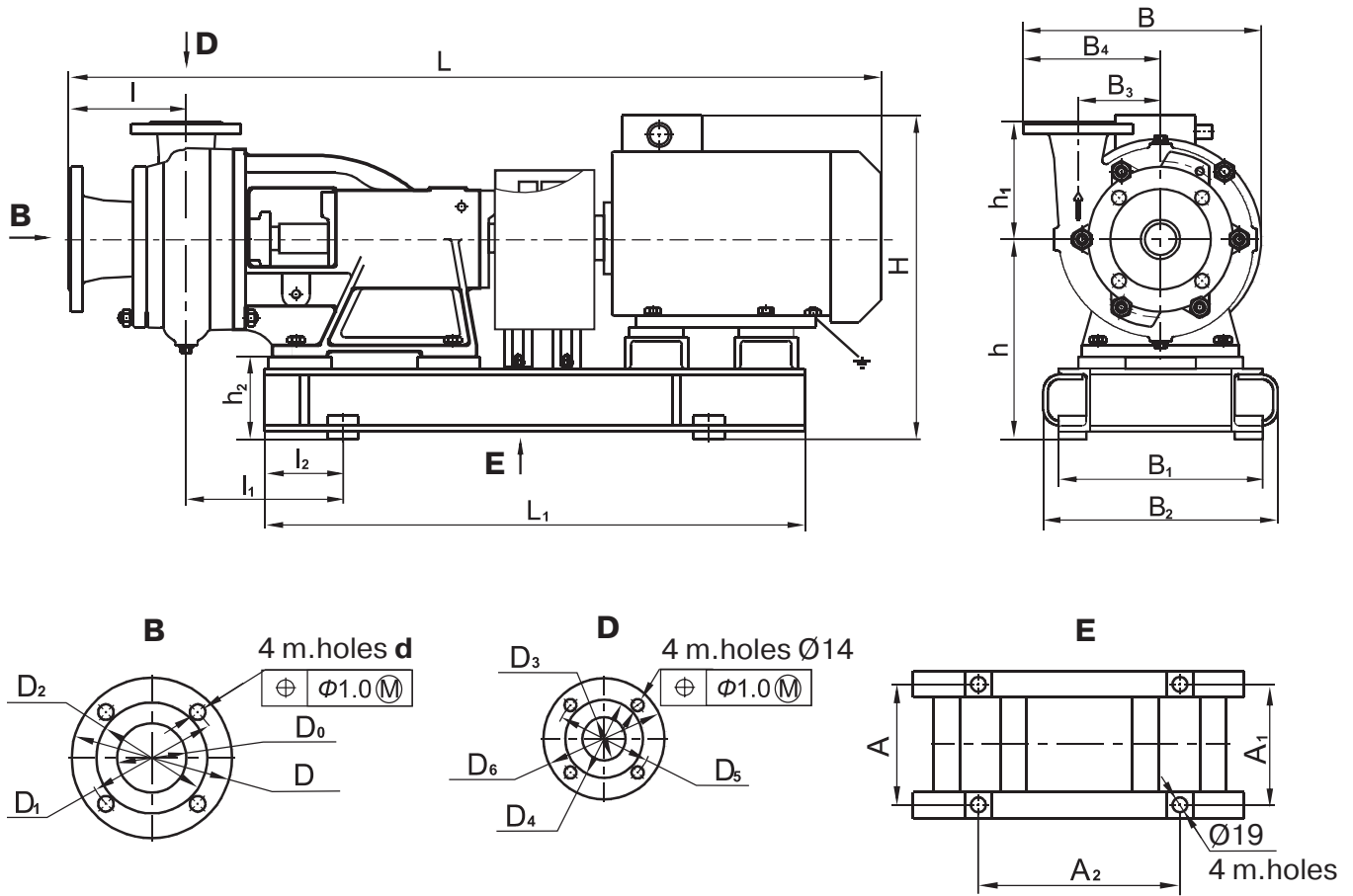

unit model	electric motor				dimensions in mm														
	model	power, kW	rotation speed, s^{-1} (rpm)	volt., V	L	L_1	I	I_1	I_2	A	A_1	A_2	B	B_1	B_2	B_3	B_4	H	
1K8/18 1K8/18a	5A80MA2	1.5	50 (3000)	220. 380	785													323	
	A80A2				790	525				109	240	240	336	230	296	312	75	135	330
	AIR80A2				790														
1K20/30m	AIR1001.2	5.5	50 (3000)	220. 380	865													343	
	A100L2				915	580					250	250	379						
1K20/30	AIR100S2	4.0	50 (3000)	220. 380	835														
	A100S2				870	555	120	185	102						300	300			
1K20/30a	AIR90L2	3.0	50 (3000)	220. 380	810														
	A90L2				845	560								275	290	290	98	163	
1K20/30b	AIR80V2	2.2	50 (3000)	220. 380	815														
	A80V2				810	525					240	240							
	5A80MV2				810														

OVERALL DIMENSIONS

unit model	elec. motor model	dimensions in mm														weight, kg
		h	h ₁	h ₂	d ₁	D	D ₀	D ₁	D ₂	D ₃	D ₄	D ₅	D ₆	D ₇	D ₈	
1K8/18 1K8/18a	5A80MA2	203	120	83	14	140	50	110	90	32	70	90	120	110	95	61
	A80A2															56
	AIP80A2															56
1K20/30m	AIR100L2	193	150	73	14	160	65	130	100	40	80	100	130	125	100	81
	A100L2															72
1K20/30	AIR100S2	193	150	73	14	160	65	130	100	40	80	100	130	125	100	73.5
	A100S2															66
1K20/30a	AIR90L2	203	150	83	14	160	65	130	100	40	80	100	130	125	100	69
	A90L2															64
1K20/30b	AIR80V2	203	150	83	14	160	65	130	100	40	80	100	130	125	100	61
	A80V2															61
	5A80MV2															63

CENTRIFUGAL END-SUCTION PUMPS OF 2K TYPE AND ELECTRIC PUMP UNITS ON THEIR BASIS

APPLICATION

Centrifugal end-suction pumps of 2K type and electric pump units on their basis are intended for pumping of water (except for sea water) in steady-state conditions with pH= 6-9.5, containing not more than 0.1% of mechanical impurities with the size of particles not more than 0.2 mm, and also, other liquids similar to water in their density and chemical activity, with the temperature from -10 to +120 °C.

The pumps are manufactured in climatic version U3.1, T2 under GOST 15150.

The pumps (units) are not intended for operation in explosion and fire hazardous premises.

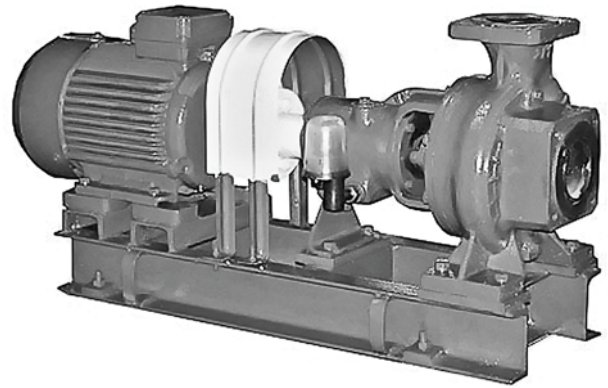

PUMP TYPE KEY

Example of designation:
2K 80-65-160 U3.1

2 K XXX - XX - XXX U3.1

upgrade (oil lubrication of bearings)

end-suction

inlet diameter, mm

outlet diameter, mm

impeller nominal diameter, mm

a, b, v – decreased impeller diameter

l, m – increased impeller diameter

climatic version and location category

TECHNICAL PARAMETERS		
parameter	2K 80-65-160	2K100-80-160
capacity, m ³ /h (l/s)	50 (13.8)	100 (27.8)
head, m	32	
rotating speed, s ⁻¹ (rpm)	48(2900)	
pump inlet pressure, MPa (kgf/cm ²), max	0.60(6.0)	
pump efficiency, %, max	72	79
pump consumed power, kW, max	7.0	13
power supply	current	alternating
	voltage, V	220V / 380V
	frequency, Hz	50

The values of the major parameters are specified for pumping of water with the temperature of 293K (20 °C) and density 1000 kg/m³

PERFORMANCE CURVE

2K80-65-160
rotation speed 48.3 s^{-1} (2900 rpm)
liquid – water (20 °C), density 1000 kg/m^3

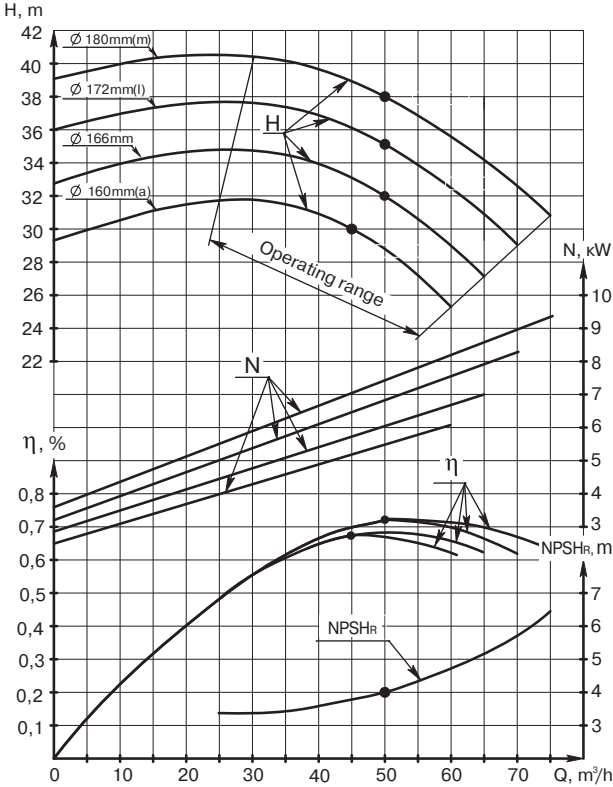

2K100-80-160
rotation speed 48.3 s^{-1} (2900 rpm)
liquid – water (20 °C), density 1000 kg/m^3

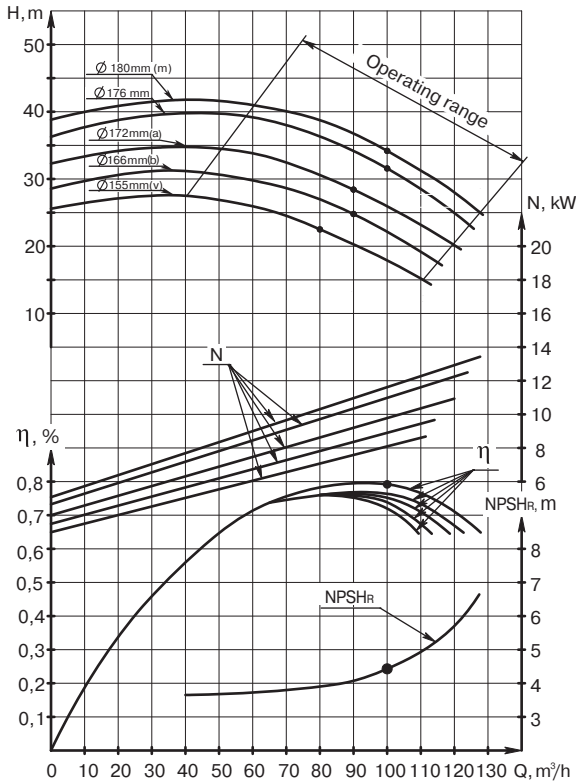

PUMP OVERALL DIMENSIONS

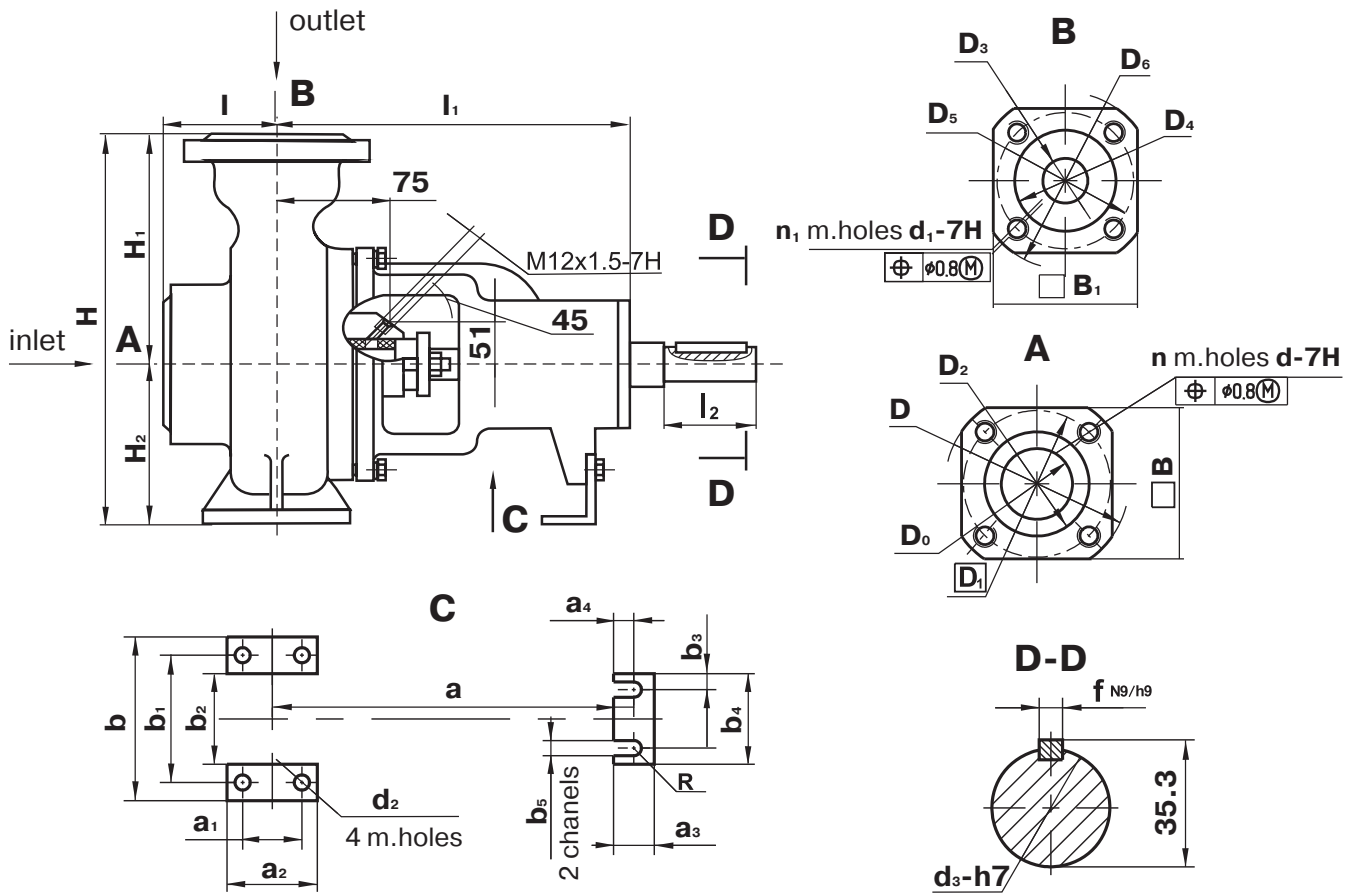

dimension designation	pump designation and model	
	H49.933.01.00.000	H49.932.01.00.000
	2K80-65-160	2K100-80-160
I	100	100
I ₁	415	415
I ₂	80	80
a	270	270
a ₁	95±0.3	95±0.3
a ₂	125	125
a ₃	45	45
a ₄	16	16
b	280	280
b ₁	212±0.5	212±0.5
b ₂	150	150
b ₃	110	110
b ₄	145	145
b ₅	14	14
B	150	155
B ₁	140	150
R	7	7
D	195	205

dimension designation	pump designation and model	
	H49.933.01.00.000	H49.932.01.00.000
	2K80-65-160	2K100-80-160
D ₀	80	100
D ₁	160	170
D ₂	133	148
D ₃	65	80
D ₄	122	133
D ₅	145	160
D ₆	180	195
d 7H	M16	M16
d ₁ 7H	M16	M16
d ₂	14	14
d ₃ h7	32 _{-0.025}	32 _{-0.025}
H	360	385
H ₁	200	225
H ₂	160	160
n	4	4
n ₁	4	4
f	10	10
weight. kg	60	61

UNIT OVERALL DIMENSIONS & TECHNICAL PARAMETERS

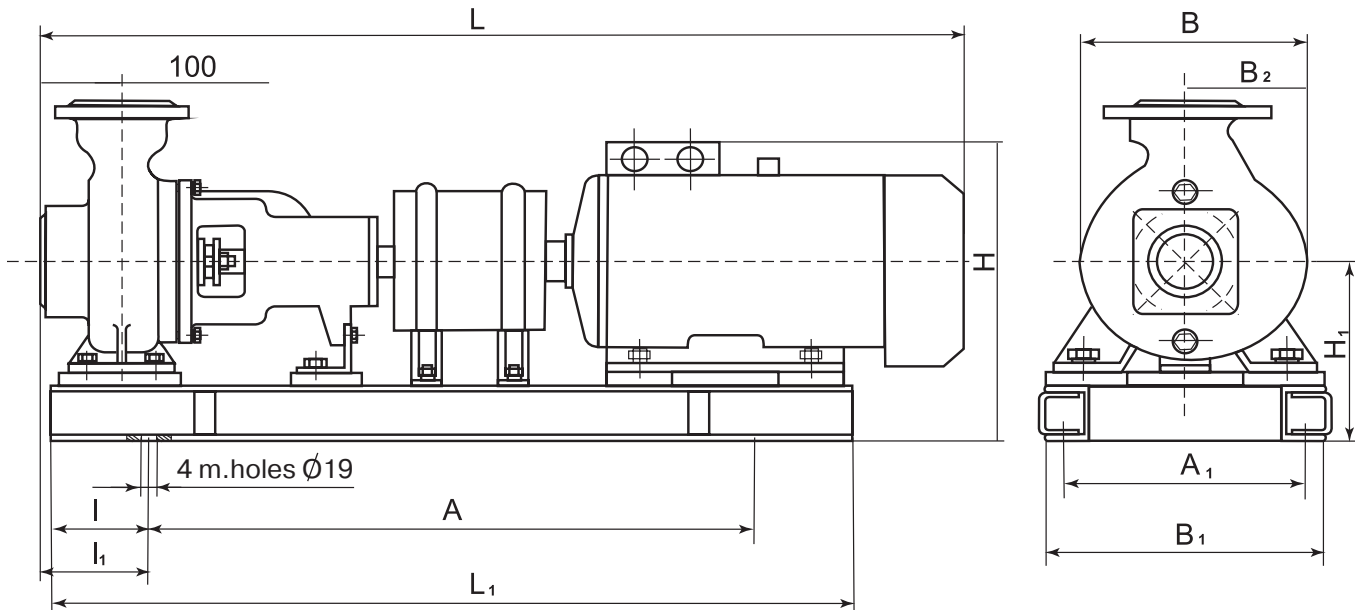

unit designation	unit model	capacity, m ³ /h	electric motor				dimensions in mm										weight, kg							
			model	power, kW	rotation speed, s ⁻¹ (rpm)	voltage, V	L	L ₁	I	I ₁	A	A ₁	H	H ₁	B	B ₁		B ₂						
H49.933.00.00.000	2K80-65-160m	75	AIR160S2	15	50 (3000)	220. 380	1125	975	150	178	620+1.1	230±1.1	540	295	350	145	160	222						
		75	5A160S2	15			1190	975					537	295	334		196	232						
		65	A132M2	11			1025	895					490	290	270		145	182						
		65	AIRM132M2	11			1018						485		288			185						
	2K80-65-160l	70	A132M2	11			1025	490					270	182										
		70	AIRM132M2	11			1018	485					288	185										
	2K80-65-160	65	A112M2	7.5			1025	825					150	178	600+1.1		230±1.1	470	290	145	173			
		65	5AM112M2	7.5			1000											460			161			
		65	AIR112M2	7.5			953											450			144			
		65	A112M2	7.5			1025											470			270	173		
2K80-65-160a	55	A112M2	7.5	1025	825	150	178	600+1.1	230±1.1	460	290	324	161											
	55	5AM112M2	7.5	1000						460			161											
	55	AIR112M2	7.5	953						450			144											
	55	A112M2	7.5	1025						470			270	173										
H49.932.00.00.000	2K100-80-160m	128	AIR160M2	18.5	50 (3000)	220. 380	1165	975	150	178	620+1.1	230±1.1	540	295	350	145	160	238						
		128	5A160M2	18.5			1220						537		334		196	245						
	2K100-80-160	125	AIR160S2	15			1125						895		150		178	600+1.1	230±1.1	540	290	145	182	
		125	5A160S2	15			1190													537			334	196
	2K100-80-160a	120	AIR160S2	15			1125						895		150		178	600+1.1	230±1.1	540	290	145	182	
		120	5A160S2	15			1190													537			334	196
	2K100-80-160b	115	A132M2	11			1025						895		150		178	600+1.1	230±1.1	490	290	145	182	
		115	AIRM132M2	11			1018													485			288	185
		110	A132M2	11			1025													490			285	182
		110	AIRM132M2	11			1018													485			288	185

CENTRIFUGAL END-SUCTION CLOSED-COUPLED ELECTRIC PUMPS OF 1KM TYPE

APPLICATION

Centrifugal end-suction closed-coupled electric pumps of **1KM** type are intended for pumping of service water (except for sea water) in steady-state conditions with pH=6-9, containing not more than 0.1% of mechanical impurities by weight with the size of particles not more than 0.2 mm, and also, other liquids similar to water in their density and chemical activity.

Temperature of pumped liquid: for electric pumps **1KM50** and **1KM65** from -10 to +85 °C; for electric pumps **1KM80** and **1KM100** from -10 to +105 °C. The electric pumps are used in water supply systems of production premises and heating of production and residential premises.

The pumps are not intended for operation in explosion and fire hazardous premises.

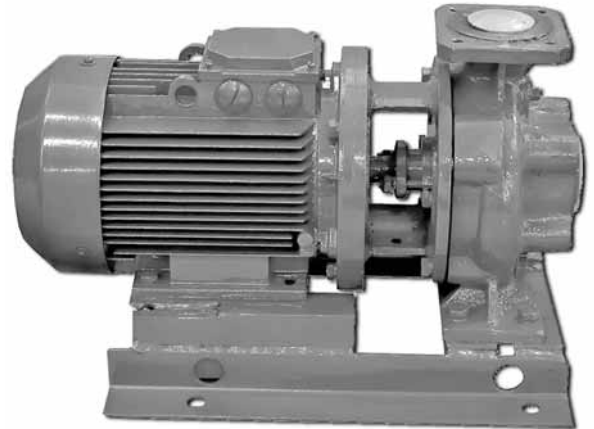

PUMP TYPE KEY

Example of designation:
1KM 50-32-125-s(τ) U3.1

1 K M XXX - XX - XXX - x U3.1

electric pump modification

cantilever closed-coupled

inlet diameter, mm

outlet diameter, mm

impeller nominal diameter, mm

a, b, v – decreased impeller diameter

l, m – increased impeller diameter

shaft sealing: **c** – gland sealing, **τ** – mechanical sealing

climatic version and location category

TECHNICAL PARAMETERS

parameter	1KM50-32-125	1KM65-50-160	1KM80-65-160	1KM100-80-160
capacity, m ³ /h (l/s)	12.5 (3.47)	25 (6.95)	50 (13.89)	100 (27.78)
head, m	20	32	32	32
pump inlet pressure, MPa (kgf/cm ²), max	0.35 (3.5)	0.35 (3.5)	0.60 (6.0)	0.60 (6.0)
rotating speed, s ⁻¹ (rpm)	48 (2900)	48 (2900)	48 (2900)	48 (2900)
pump power, kW, max	1.6	4.3	7.0	12.6
power supply	alternating current, voltage–220V / 380V, frequency–50 Hz			

PERFORMANCE CURVE

1KM50-32-125

rotation speed 48 s^{-1} (2900 rpm)

liquid – water (20 °C), density 1000 kg/m^3

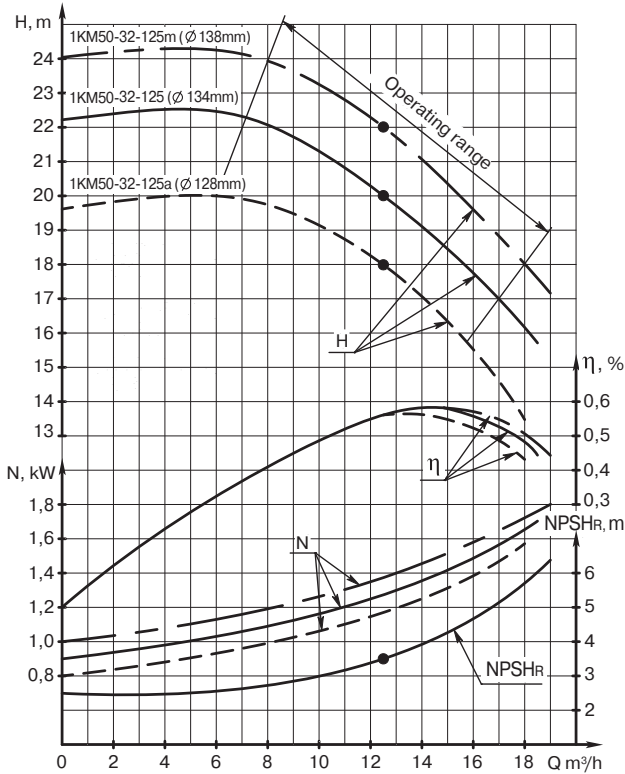

1KM80-65-160

rotation speed 48 s^{-1} (2900 rpm)

liquid – water (20 °C), density 1000 kg/m^3

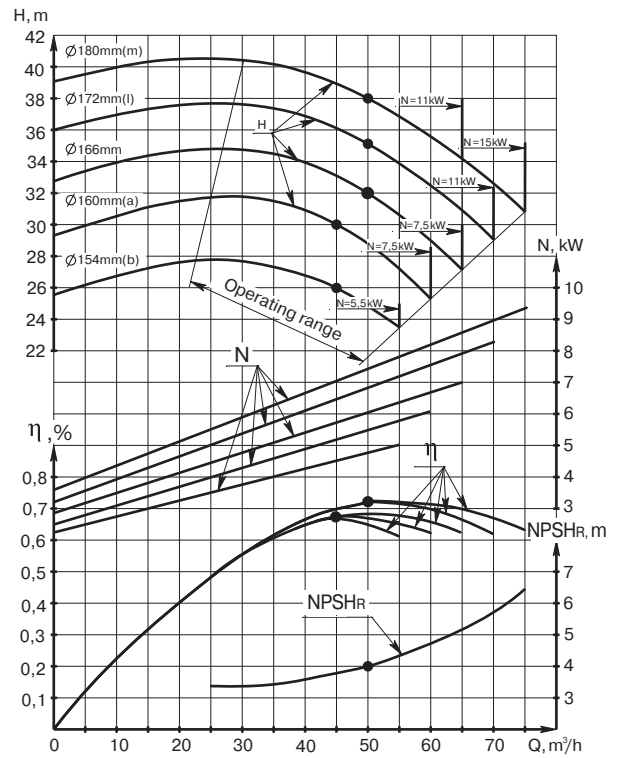

1KM65-50-160

rotation speed 48 s^{-1} (2900 rpm)

liquid – water (20 °C), density 1000 kg/m^3

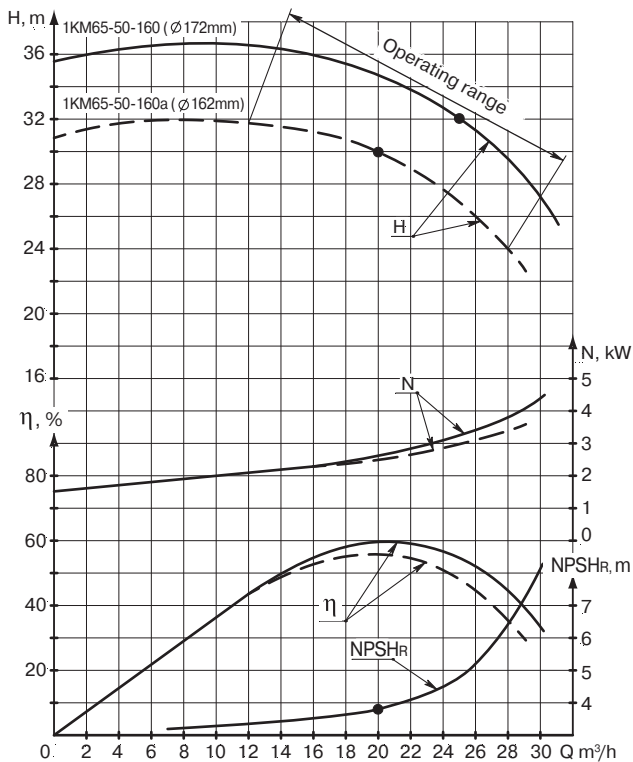

1KM100-80-160

rotation speed 48 s^{-1} (2900 rpm)

liquid – water (20 °C), density 1000 kg/m^3

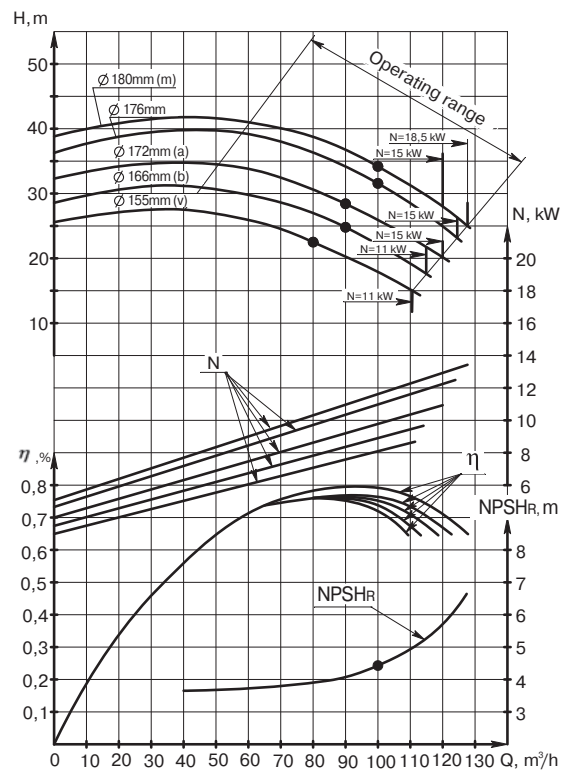

OVERALL DIMENSIONS

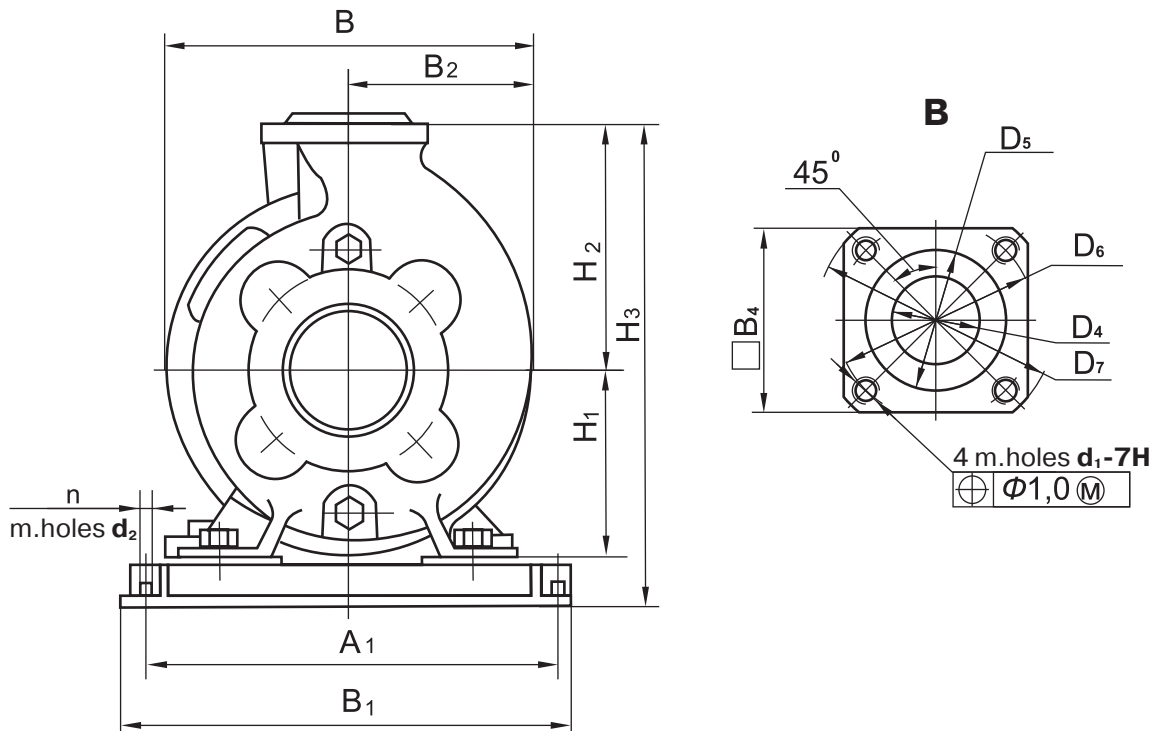
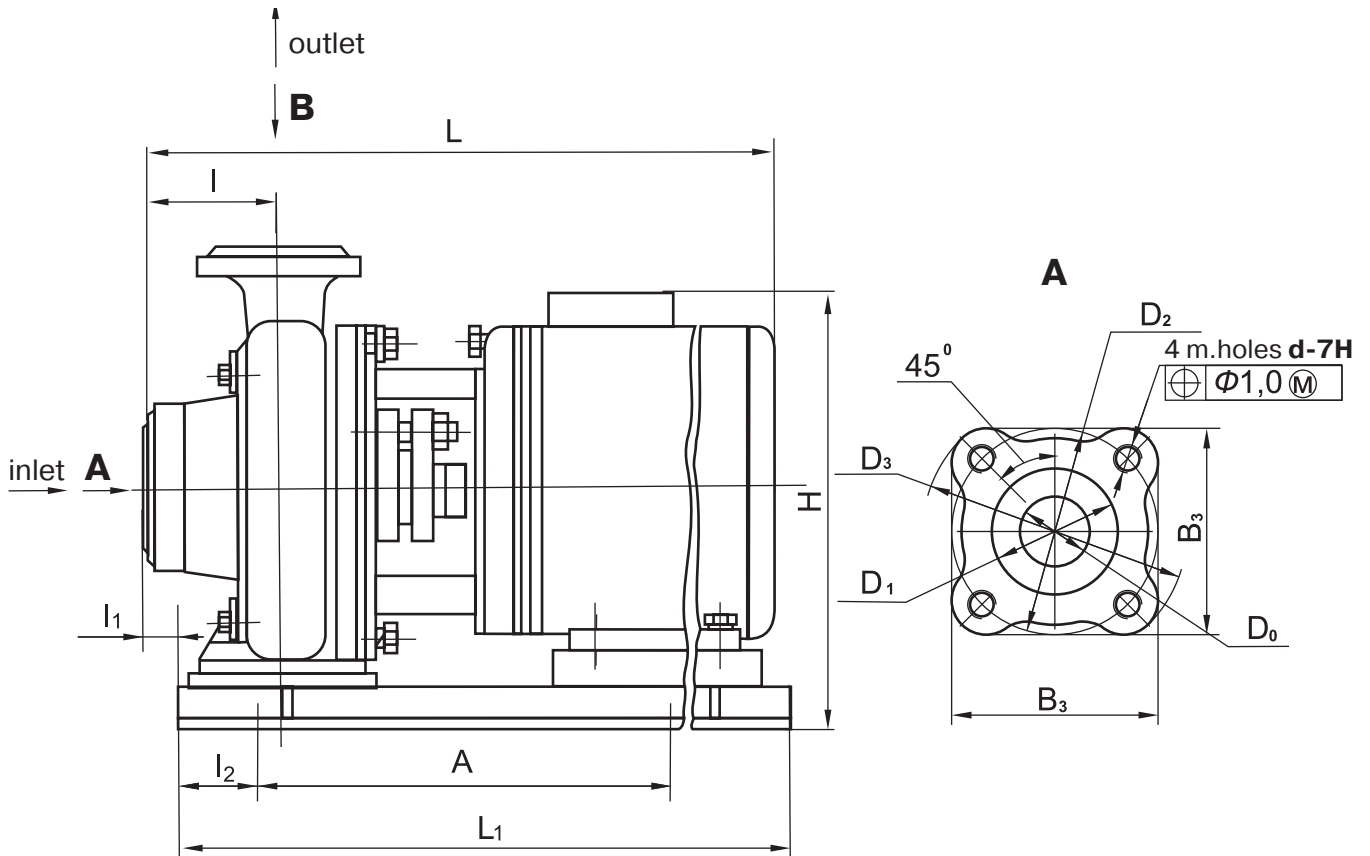

OVERALL DIMENSIONS

electric pump model	electric motor				dimensions in mm													
	capacity, m ³ /h, max	model	power, kW	voltage, V	rotation speed, s ⁻¹ (rpm)	delivery	L	L ₁	I	I ₁	I ₂	I ₃	A	A ₃	A ₃	A ₃		
1KM50-32-125m ⁻⁵	18	AIR90L2J	3.0	380	50 (3000)	on sub-frame	480	440	15	40	-	330±2.8	250±2.8	-	-	-		
1KM50-32-125 ⁻⁵	17	AIR80B2J	2.2				500	-	-	-	-	-	-	-	-	-	-	-
1KM50-32-125a ⁻⁵	15.6	AIR80B2J	2.2				500	-	80	140±0.5	330±1.1	-	-	-	-	-	-	-
1KM65-50-160 ⁻⁵	32	AIR100L2J	5.5	380	on base plate	560	460	-	30	-	100	-	300±2.8	70±0.5	70±0.5			
1KM65-50-160a ⁻⁵	32	AIR100L2J	5.5			560	-	-	190±0.5	338±1.1	-	-	-	-	-	-	-	

electric pump model	delivery	dimensions in mm														weight, kg												
		H	H ₁	H ₂	H ₃	H ₄	H ₅	B	B ₁	B ₂	B ₃	B ₄	B ₅	d	d ₁		d ₂	n	D ₀	D ₁	D ₂	D ₃	D ₄	D ₅	D ₆	D ₇		
1KM50-32-125m ⁻⁵	on subframe	306	-	312	-	187	88	-	-	-	-	-	-	-	-	19	4	-	-	-	-	-	-	-	-	-	50.0	43.0
	on base plate	-	-	-	-	-	-	-	-	-	-	-	-	-	-	-	-	-	-	-	-	-	-	-	-	-	48.5	41.0
1KM50-32-125 ⁻⁵	on subframe	112	140	-	-	300	110	105	-	-	-	-	-	-	-	50	90	110	140	32	78	100	135	-	-	40.0	37.0	
	on base plate	296	-	-	-	200	100	-	-	-	-	-	-	-	-	-	-	-	-	-	-	-	-	-	-	38.5	35.0	
1KM50-32-125a ⁻⁵	on subframe	-	-	-	-	252	237	-	-	-	-	-	-	-	-	14	6	-	-	-	-	-	-	-	-	40.0	37.0	
	on base plate	-	-	-	-	-	-	-	-	-	-	-	-	-	-	-	-	-	-	-	-	-	-	-	-	38.5	35.0	
1KM65-50-160 ⁻⁵	on subframe	338	132	160	-	250	350	125	140	125	-	-	-	-	-	65	122	145	180	50	102	125	160	-	-	71.0	62.5	
	on base plate	-	-	-	-	292	279	-	-	-	-	-	-	-	-	-	-	-	-	-	-	-	-	-	-	69.0	60.5	
1KM65-50-160a ⁻⁵	on subframe	-	-	-	-	-	-	-	-	-	-	-	-	-	-	14	6	-	-	-	-	-	-	-	-	71.0	62.5	
	on base plate	-	-	-	-	-	-	-	-	-	-	-	-	-	-	-	-	-	-	-	-	-	-	-	-	69.0	60.5	

OVERALL DIMENSIONS

electric pump model	capacity, m ³ /h, max	electric motor					dimensions in mm										weight, kg
		model	N, kW	voltage, V	rotation speed, s ⁻¹ (rpm)	L	L ₁	I	I ₁	I ₂	A	A ₁	H	H ₁	H ₂	H ₃	
1KM80-65-160m ^s _Т	75	5A160MA2NJ	15			830	570					505	160				
1KM80-65-160л ^s _Т	65	AD132M2J	11			660	520					462	132				
1KM80-65-160 ^s _Т	70																
1KM80-65-160a ^s _Т	65	AIRM112M2J	7.5			600	520					462	112	200	462		
1KM80-65-160b ^s _Т	60																
1KM80-65-160 ^s _Т	55	AIR100L2J	5.5	380	50 (3000)	570		100	27.5	25	230+1.1		100				
1KM100-80-160m ^s _Т	128	5A160MB2NJ	18.5			830	570					505	160	225	487	132	
1KM100-80-160 ^s _Т	120																
1KM100-80-160a ^s _Т	125	5A160MA2NJ	15			830	570					505	160	225	487	132	
1KM100-80-160b ^s _Т	120																
1KM100-80-160v ^s _Т	114	AD132M2J	11			660	520					487	132				
1KM100-80-160v ^s _Т	110	5A160SA2NJ	11			800	570					505	160				

electric pump model	dimensions in mm										weight, kg							
	B	B ₁	B ₂	B ₃	B ₄	d	d ₁	d ₂	n	D ₀		D ₁	D ₂	D ₃	D ₄	D ₅	D ₆	D ₇
1KM80-65-160m ^s _Т																	227	
1KM80-65-160л ^s _Т																	147	
1KM80-65-160 ^s _Т				150	140					80	133	160	195	65	122	145	180	130
1KM80-65-160a ^s _Т																	130	
1KM80-65-160b ^s _Т						M16	M16	19	4								118	
1KM100-80-160m ^s _Т	350	302	175														237	
1KM100-80-160 ^s _Т										100	148	170	205	80	133	160	195	227
1KM100-80-160a ^s _Т				155	150													
1KM100-80-160b ^s _Т																	147	222
1KM100-80-160v ^s _Т																		

CENTRIFUGAL END-SUCTION CLOSED-COUPLED ELECTRIC PUMPS OF IN-LINE 1KML TYPE

APPLICATION

Centrifugal end-suction closed-coupled low-noise electric pumps of linear **1KML** type are intended for pumping of service water (except for sea water) in steady-state conditions with pH=6-9.5, temperature from -10 to +120 °C, containing not more than 0.1% of mechanical impurities by weight with the size of particles not more than 0.2 mm, and also, other liquids similar to water in their density and chemical activity.

The electric pumps are used as rising and circulation pumps in water supply systems of production premises and heating of production and residential premises.

The pumps are not intended for operation in explosion and fire hazardous premises.

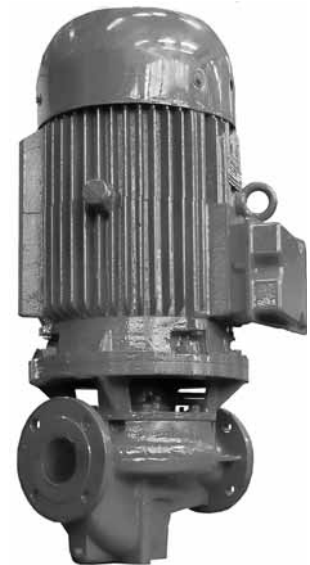

PUMP TYPE KEY

Example of designation:
1KML 80-160τ U3.1

1 K M L XX - XXX x U3.1

electric pump modification

end-suction, closed-coupled, in-line

inlet and outlet diameter, mm

impeller nominal diameter, mm

a, b, – decreased impeller diameter

l, m – increased impeller diameter

no designation – gland sealing

τ – mechanical sealing

climatic version and location category

TECHNICAL PARAMETERS			
parameter	1KML 80-160	1KML 65-200	1KML 65-200
capacity, m ³ /h	100	50	50
head, m	32	50	32
pump inlet pressure, MPa (kgf/cm ²), max	0.35 (3.5)		
pump power, kW, max	14	14.5	7
rotating speed, s ⁻¹ (rpm)	48.3 (2900)		
power supply	alternating current, voltage – 220V / 380B, frequency – 50 Hz		

TECHNICAL PARAMETERS																																																							
electric pump model	capacity, m ³ /h	electric motor model	power, kW	dimensions in mm											weight kg																																								
				L	L ₁	B	B ₁	D	D ₁	D ₂	D ₃	H	h	b																																									
1KML65-200 1KML65-200T	72	5A160MB2NJ	18.5	530	265	417	242	65	122	145	180	880	160	45	205																																								
		AIR160M2Sp19				420	245					775			157																																								
62	5A160MA2NJ	15	417			242	880					195																																											
	AIR160S2Sp19		420			245	735					147																																											
1KML65-200-a 1KML65-200T-a	68	5A160MA2NJ	15			380	190					417			242	65	122	145	180	880	160	45	195																																
		AIR160S2Sp19										420			245					735			147																																
53	5A160SA2NJ	11	417									242			880					190																																			
	AD132M2J		355									178			627					130																																			
1KML65-200-b 1KML65-200T-b	65	5A160SA2NJ	11									380			190					417			242	65	122	145	180	880	160	45	190																								
		AD132M2J																		355			178					627			130																								
1KML65-160-m 1KML65-160T-m	75	5A160M2NJ	15																	380			190					417			242	65	122	145	180	910	160	45	190																
		AIR160S2Sp19																										420			245					760			150																
65	5A160SA2NJ	11	417	242	910			190																																															
	AD132M2J		355	178	655			120																																															
1KML65-160-l 1KML65-160T-l	70	5A160SA2NJ	11	380	190			417	242	65	122		145	180														910			160					45			190																
		AD132M2J						355	178																			655											120																
1KML65-160 1KML65-160T	65	AIRM112M2J	7.5			380	190	340	188							65	122	145	180		570	160						45											105																
								1KML65-160-a 1KML65-160T-a	60												AIRM112M2J																		7.5	380	190	340	188	65	122	145	180	160	45	105					
1KML80-160 1KML80-160T	125	5A160MA2NJ	15					530																																		265	417								242	80	133	160	195
AIR160S2Sp19		420							245												800																		150																
1KML80-160-a 1KML80-160T-a	120	5A160MA2NJ	15						530			265			417						242			80	133	160	195		910	184									50				220												
		AIR160S2Sp19													420						245								800														150												
1KML80-160-b 1KML80-160T-b	115	5A160SA2NJ	11												530					265	417		242						80			133	160	195	910		184	50					220												
		AD132M2J																			355		178												655								120												

OVERALL DIMENSIONS

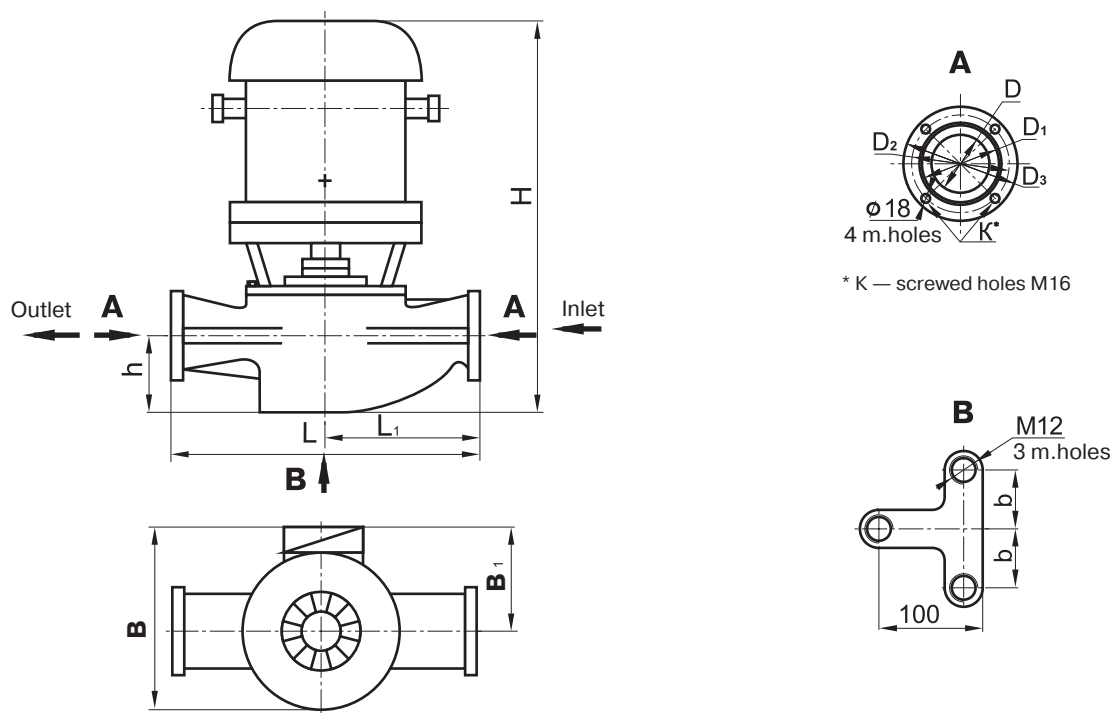

PERFORMANCE CURVE

1KML65-160

rotation speed 48.3 s^{-1} (2900 rpm)

liquid – water (20 °C), density 1000 kg/m^3

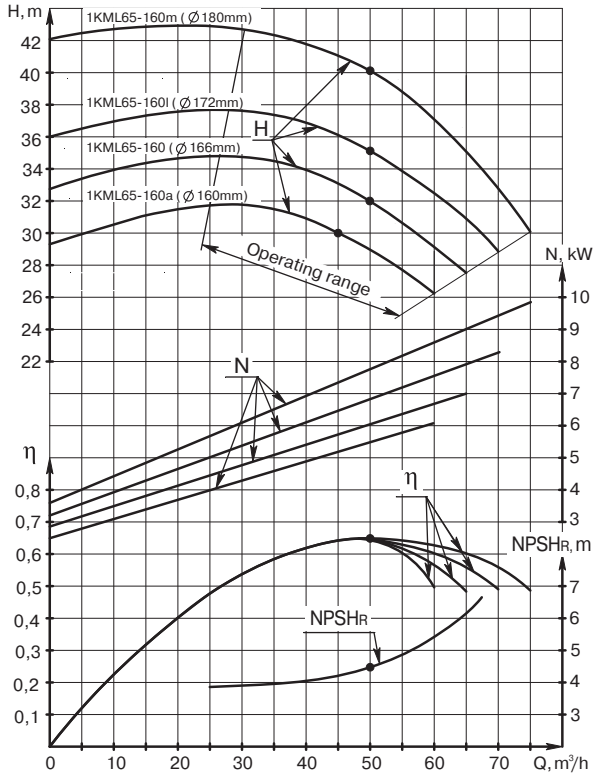

1KML65-200

rotation speed 48.3 s^{-1} (2900 rpm)

liquid – water (20 °C), density 1000 kg/m^3

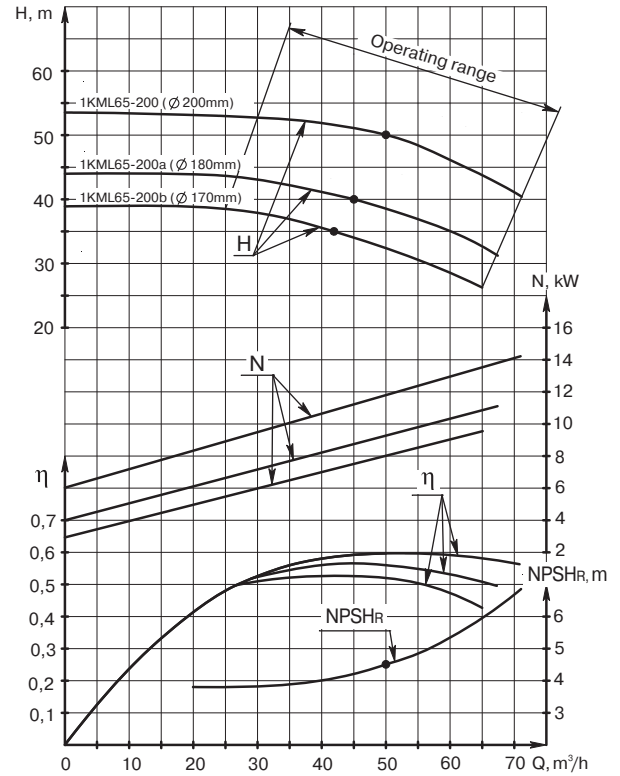

1KML80-160

rotation speed 48.3 s^{-1} (2900 rpm)

liquid – water (20 °C), density 1000 kg/m^3

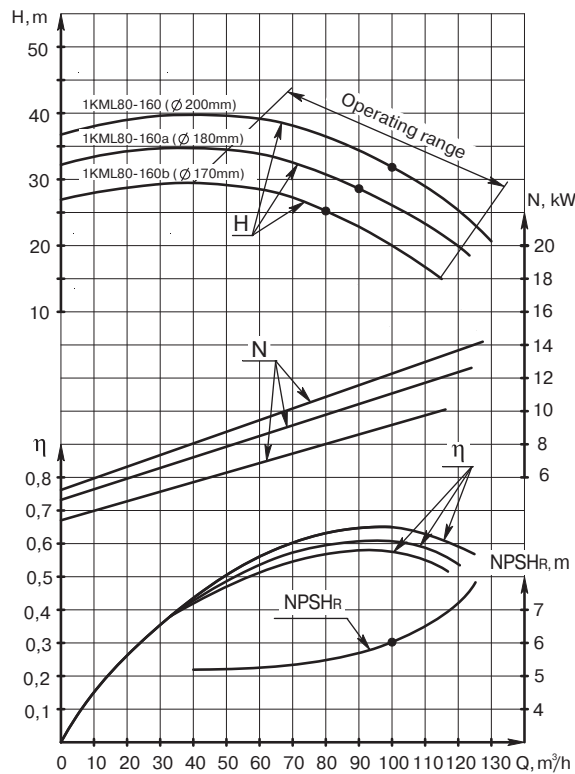

VORTEX PUMPS OF VK, VKS, VKO TYPE AND ELECTRIC PUMP UNITS ON THEIR BASIS

APPLICATION

Vortex pumps **VK, VKS, VKO** and electric pump units on their basis are intended for pumping of water, neutral, chemically active liquids in which the linear speed of the liquid-end materials continuous corrosion is not more than 0.1 mm per year under GOST 9.908-85, with the kinematic viscosity up to $36 \times 10^{-6} \text{ m}^2/\text{s}$ (36 cSt), with the content of solid particles not more than 0.01% by weight, and the size of particles not more than 0.05 mm. The pumped water temperature is: A (-15 +85 °C), B and K (-40 +85 °C).

The pumps belong to type 1 products (repairable) under GOST 27.003-90 and are manufactured in climatic versions U3.1, U2 and T2 under GOST15150-69. The pumps are manufactured with the shaft gland sealing and do not provide pumping of flammable, harmful and highly-inflammable liquids.

The pumps (units) are not intended for operation in explosion and fire hazardous premises.

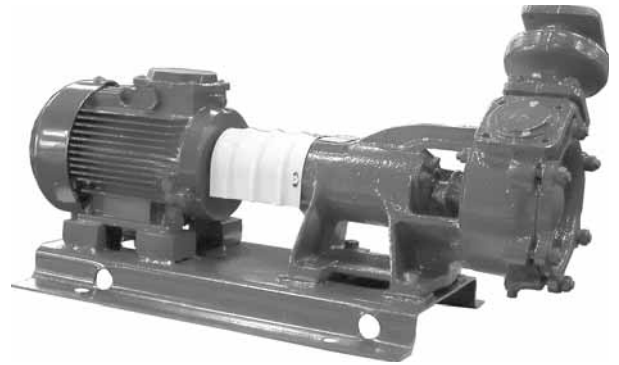

PUMP TYPE KEYS

Example of designation:

VKS2/26 B – U2

vortex, cantilever, self-priming

capacity, l/s

head, m

material designation:

A – cast iron; **B** – bronze; **K** – non-corrosive

U3.1, U2, T2 – climatic version and location category

VKS X / XX X UX

Example of designation:

VKO2/26 A – U3.1 TU 26-06-1213-81

vortex, cantilever, heated (cooled)

capacity, l/s

head, m

liquid-end material:

A – cast iron; **B** – bronze; **K** – non-corrosive

U3.1, U2, T2 – climatic version and location category

VKO X / XX X UX

parameter		pump (unit) model					
		VK, VKS, VKO 1/16	VK, VKS, VKO 2/26	VK, VKS, VKO 4/28	VK, VKS, VKO 5/24	VK, VKS, VKO 5/32	VK, VKS, VKO 10/45
capacity	l/s	1.0	2.0	4.0	5.0		10.0
	m ³ /h	3.6	7.2	14.4	18.0		36.0
head, m		16	26	28	24	32	45
self-priming lift, m, max (for self-priming pumps)		4.0			3.5	3.0	
allowable self-priming time, s, max (for self-priming pumps)		600					
pump inlet pressure, MPa (kgf/cm ²), max		0.25 (2.5)					
pump consumed power, kW, max		1.2	4.6	7.0	8.3	8.8	27
power supply	current	alternating					
	voltage, V	220, 380, 660					
	frequency, Hz	50					
efficiency, %	pump	28	33	41	38	39	35
	unit	22	26	32	30		31
net positive suction head, m		4.0	5.0	6.0	6.5		7.0
external leakage through the gland seal, l/h (drops/min), max		0.3 - 1.0 (50-170)					

The values of the major parameters are specified for pumping of water with the temperature of 293K (20 °C) and density 1000 kg/m³

PERFORMANCE CURVE

VK1/16, VKS1/16, VKO1/16
rotation speed 24.2 s^{-1} (1450 rpm)
liquid – water (20 °C), density 1000 kg/m³

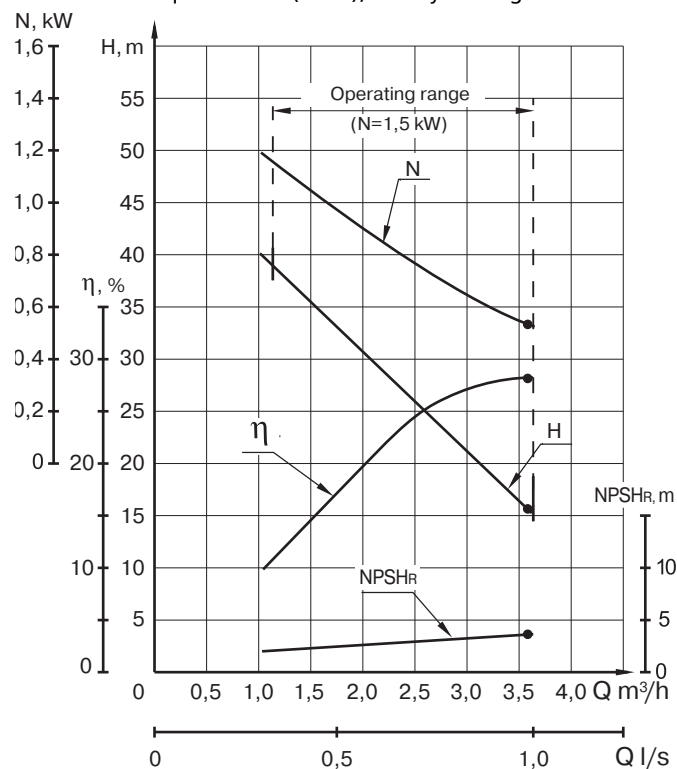

PERFORMANCE CURVE

VK2/26, VKS2/26, VKO2/26

rotation speed 24.2 s^{-1} (1450 rpm)

liquid – water (20 °C), density 1000 kg/m^3

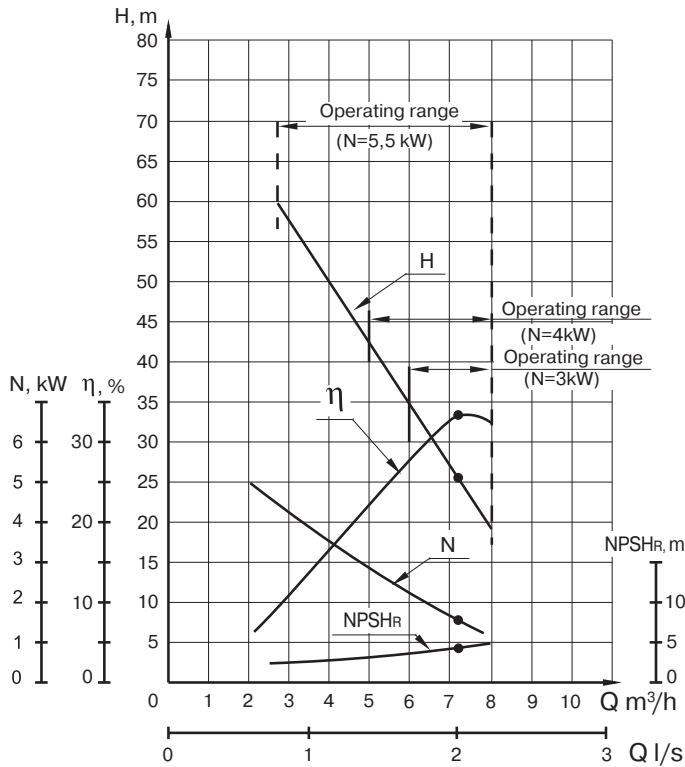

VK2/26, VKS2/26, VKO2/26

rotation speed 16 s^{-1} (970 rpm)

liquid – water (20 °C), density 1000 kg/m^3

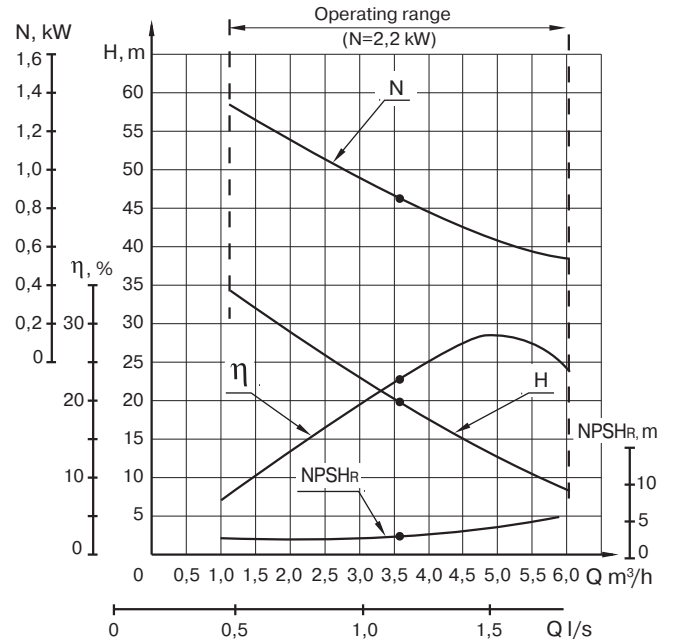

VK4/28, VKS4/28, VKO4/28

rotation speed 24.2 s^{-1} (1450 rpm)

liquid – water (20 °C), density 1000 kg/m^3

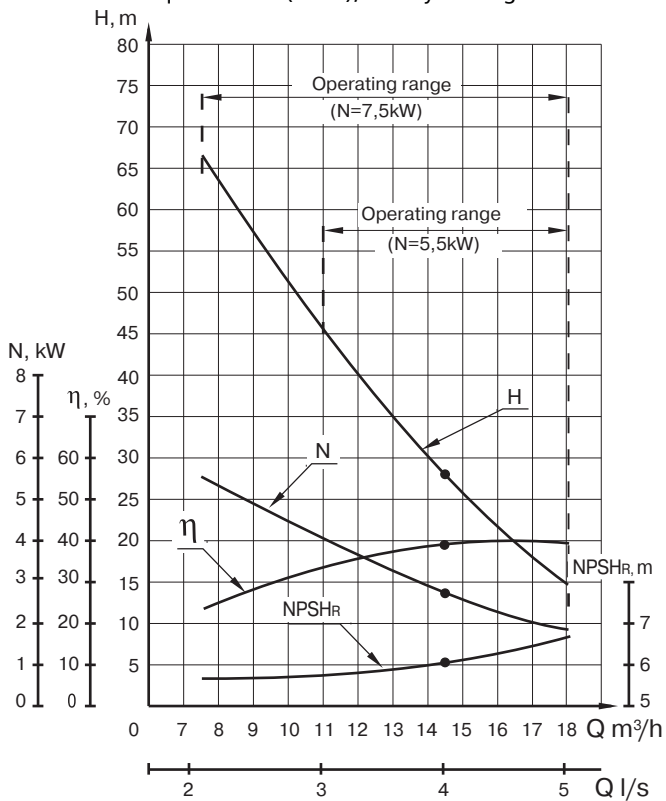

VK5/24, VKS5/24, VKO5/24

rotation speed 24.2 s^{-1} (1450 rpm)

liquid – water (20 °C), density 1000 kg/m^3

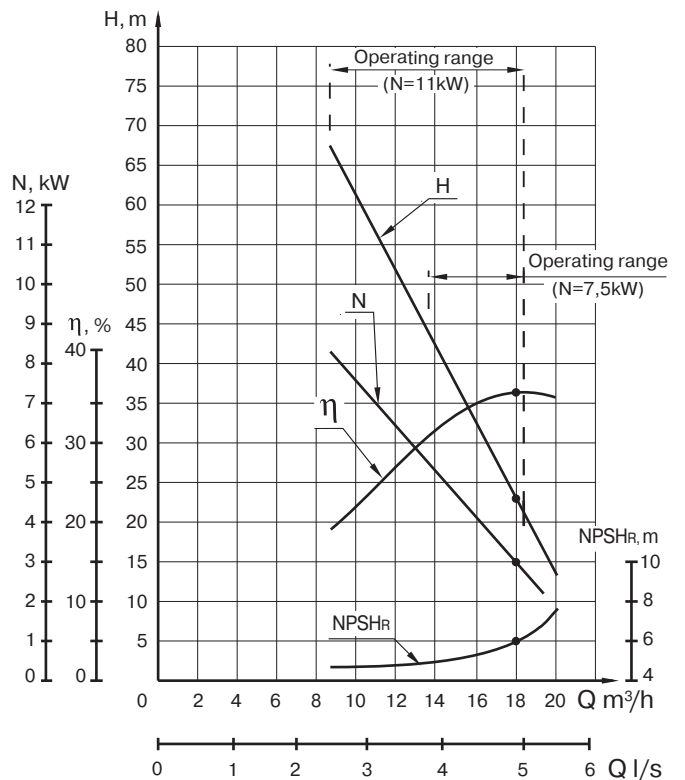

PERFORMANCE CURVE

VK5/32, VKS5/32, VKO5/32

rotation speed 24.2 s^{-1} (1450 rpm)

liquid – water (20 °C), density 1000 kg/m^3

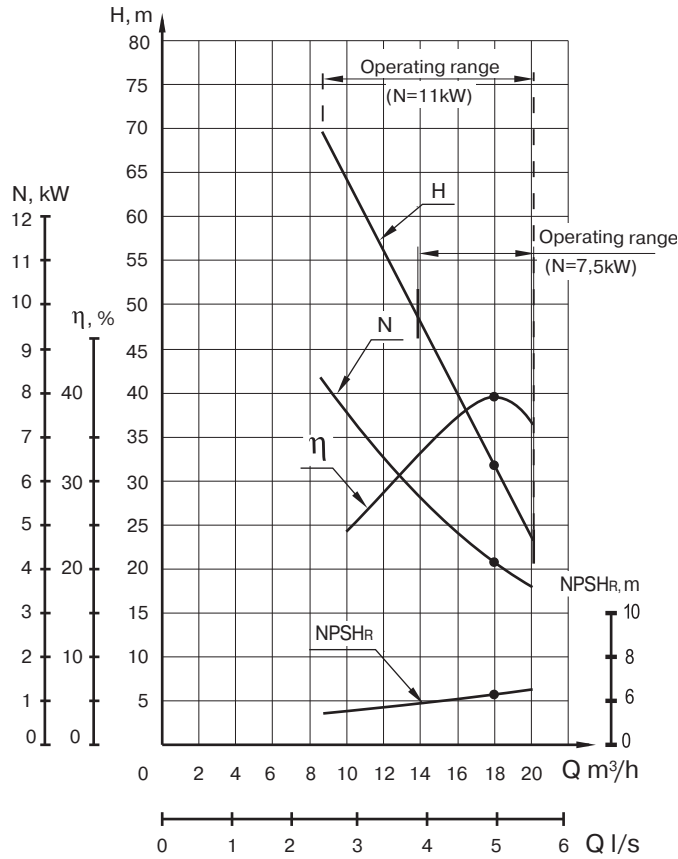

VK10/45, VKS10/45, VKO10/45

rotation speed 24.2 s^{-1} (1450 rpm)

liquid – water (20 °C), density 1000 kg/m^3

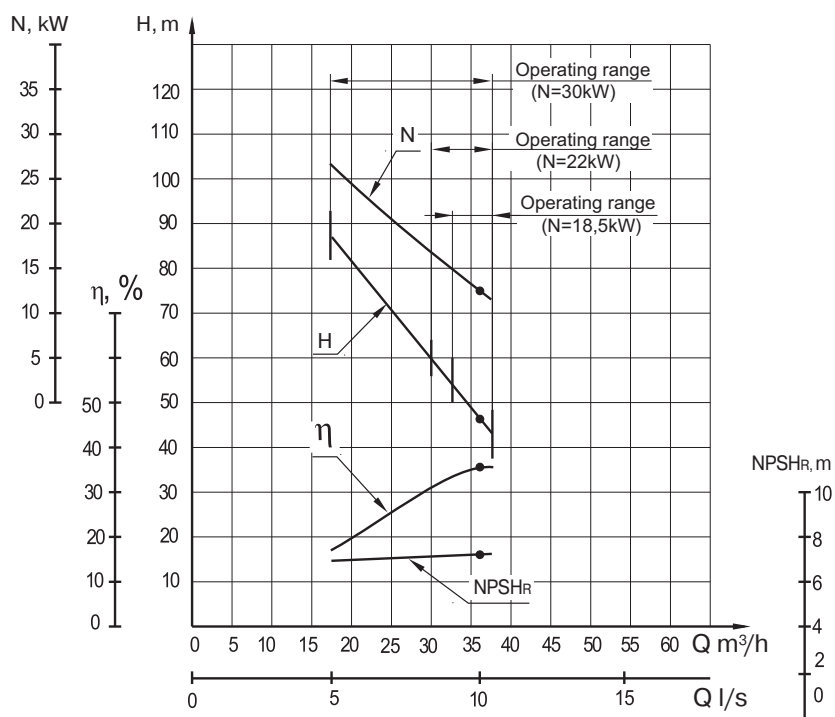

OVERALL DIMENSIONS

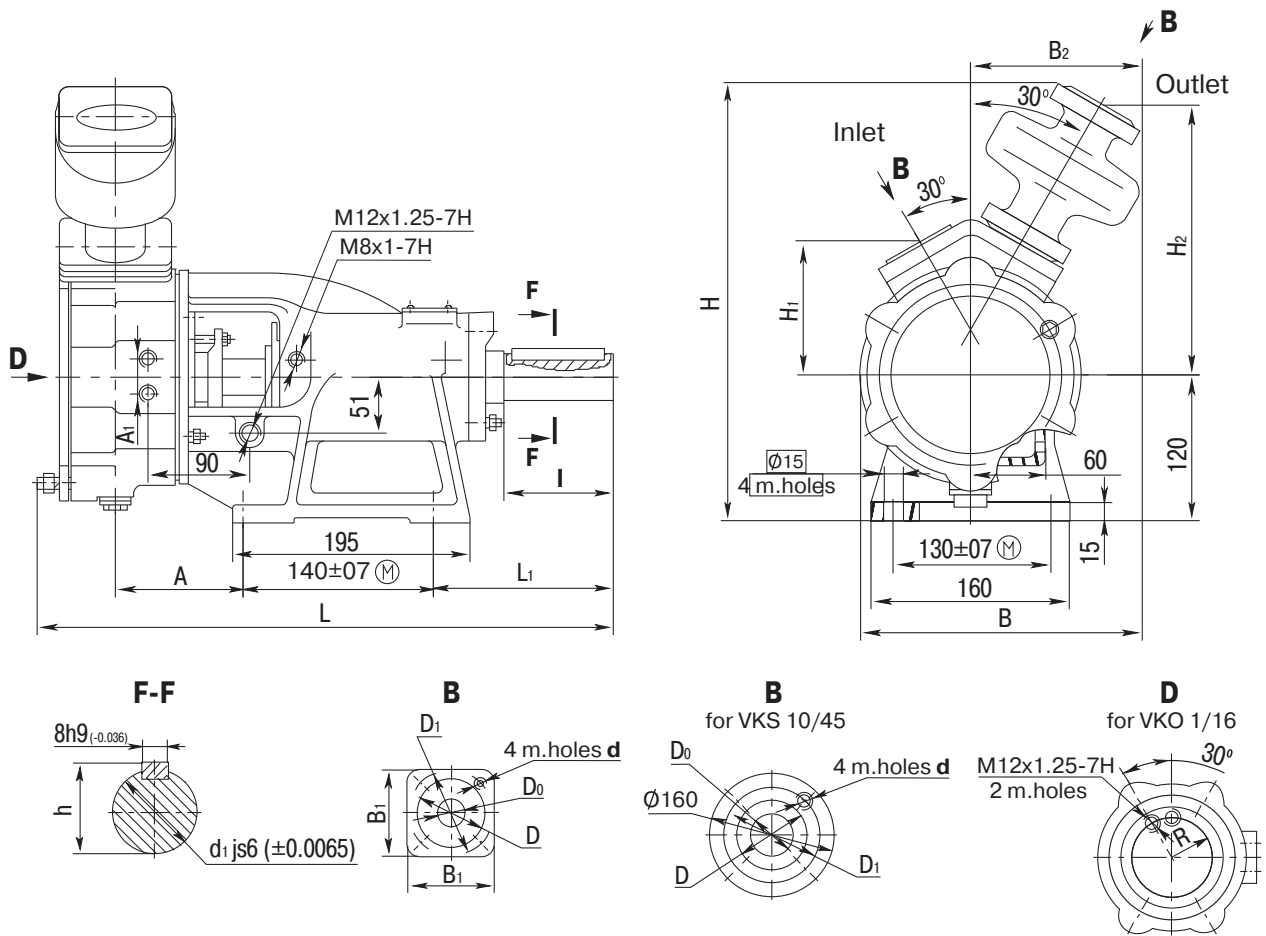

pump model	dimensions in mm																		weight, kg, for designation			
	L	L ₁	B	B ₁	B ₂	H	H ₁	H ₂	A	A ₁	D ₀	D	D ₁	d	d ₁	h	I	R	A	B	K	
VK1/16	413		185		-	250		-		-									-	26.2	30.9	27.9
VKS 1/16	420		233	78	140	360	108	221		-	25	60	75	M10					-	29.7	34.0	33.0
VKO 1/16	424		185		-	250		-	122	30									55	29.8	-	.
VK 2/26	422		190		-	250		-		-									-	29.7	33.5	31.8
VKS 2/26	427		250		155	370	107	220		-									-	33.2	37.9	36.5
VKO 2/26	448		185		-	250		-		30									68	32.4	-	-
VK 4/28	434		204		-	254		-		-	40	80	100						-	28.0	36.8	34.9
VKS 4/28		95	260		160	366	110	223		-						25	28	50	-	35.6	39.0	38.0
VKO 4/28	454		196		-	254		-		30									72	36.5	-	-
VK 5/24	440		217		-	260		-		-									-	33.7	39.4	38.3
VKS 5/24			269		162	374		228	126	-				M12					-	37.9	43.0	42.0
VKO 5/24	460		210		-	260		-		30									79	40.0	-	-
VK 5/32	440		217		-	260	115	-		-	50	90	110						-	32.0	39.4	38.3
VKS 5/32			269		162	374		228		-									-	37.9	43.0	42.0
VKO 5/32	460		210		-	260		-		30									79	40.0	-	-
VK 10/45	479		243		-	270		-	135	-									-	44.0	49.8	47.3
VKS 10/45		112	335	125	215	425	121	261		-	65	110	130			28	31	60	-	48.0	54.5	54.0
VKO 10/45	508		240		-	270		-	143	60									87	50.0	-	-

OVERALL DIMENSIONS

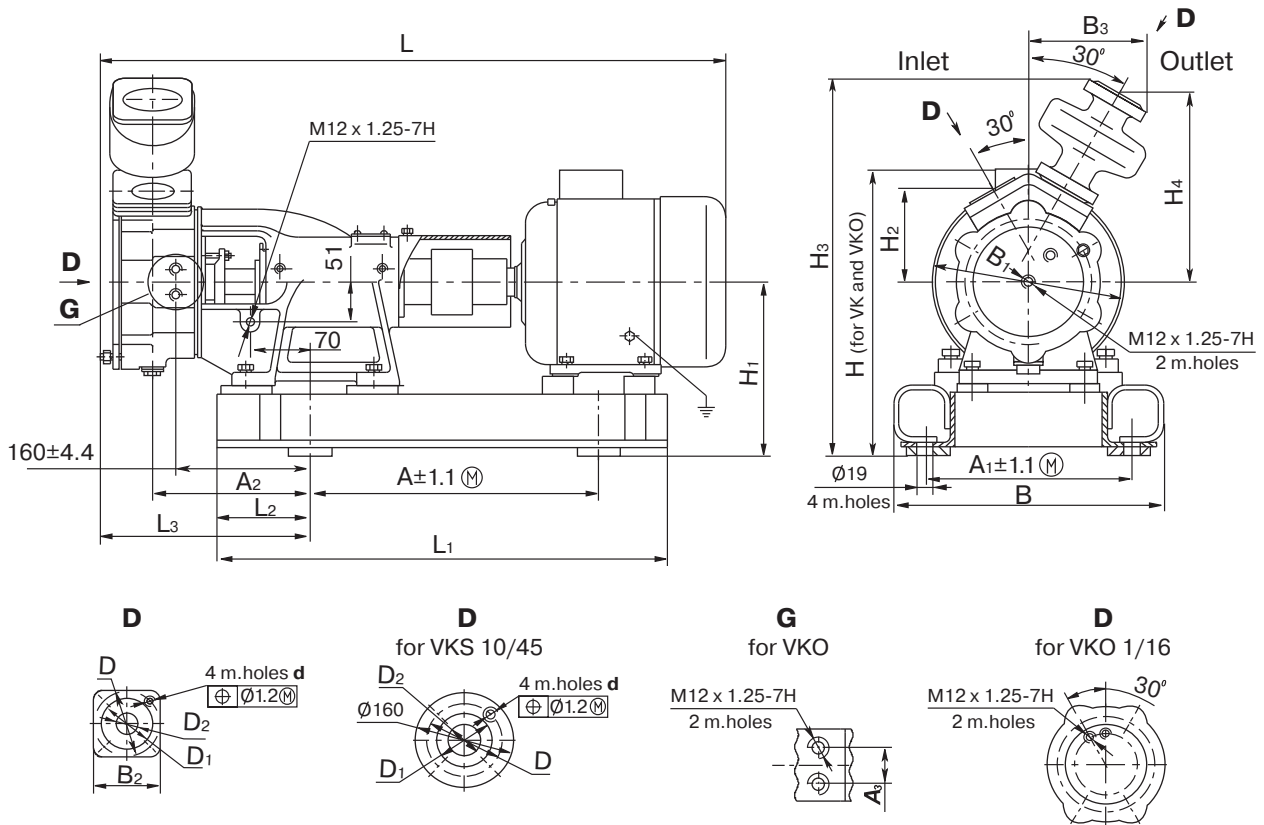

A*	model	electric motor power, kW	rotation speed, s ⁻¹ (rpm)	dimensions in mm																
				L	L ₁	L ₂	L ₃	B	B ₁	B ₂	H	H ₁	H ₂	A	A ₁	A ₂	D	D ₁	D ₂	d
VK 1/16	A80B4	1.5	24 (1450)	755	525	109	248	315	220	78	333	203	108	336	240	190	75	60	25	M10-7H
	5A80MB4																			
	AIR80B4																			
	ADM80B4																			
	5A80MB4-OM2																			
	AIR80B4-OM2																			
VK 2/26	AIR100L6	2.2	16 (970)	835							344								M12-7H	
	A100L6			863	580						370		379							
	ADM100L6			835							344									
	A100S4			820							328									
	AIR100S4	3		805	555	102		300	240		344	198		365	250					
	ADM100S4																			
	AIP100L4	4	24 (1450)	835																
	A100L4			863	580	257				100	375	107		379	190	100	80	40		
	ADM100L4			835							344									
	5A100L4-OM2										371									
	A112M4	5.5		925								388								
	AIR112M4			885	630	109		290	250		366	203		413	240					
	ADM112M4										376									
	AIRM112M4										371									
5AM112M4										371										

* Model unit. Unit constructed on base plate.

OVERALL DIMENSIONS

model		electric motor power, kW	rotation speed, s ⁻¹ (rpm)	dimensions in mm																				
A*	electric motor			L	L ₁	L ₂	L ₃	L ₄	B	B ₁	B ₂	H	H ₁	H ₂	A	A ₁	A ₂	D	D ₁	D ₂	d			
VK 4/28	AIR112M4 AIRM112M4	5.5	24(1450)	895																				
	5AM112M4			942	630	109	477		290					203	413									
	A112M4			937																				
	ADM112M4	905						269		245	100			110				100	80	40				
	A132S4	7.5		967																				
	AIRM132S4			922													240	195						
AIR132S4	925			640		529									432									
VK 5/24, VK 5/32	AIRM132S4	7.5		928		102			300				210											
	A132S4			973				275		258	108			115				110	90	50				
	AIRM132M4	11		966	680		560								451									
	A132M4			973																				
VK 10/45	AIR160M4	18.5		1167	780				331				242			290								
	5A160M4			1207																				
	AIR180S4	22		1137			588																	
	A180S4			1152	777	97		297	356	350	125			121	560		205	130	110	65				
	AIR180M4	30		1187									262		315									
	4AMH180S4			1087	815		724		430															
	A180M4			1212																				

model		el. motor power, kW	rotation speed, s ⁻¹ (rpm)	dimensions in mm																					
A*	electric motor			L	L ₁	L ₂	L ₄	B	B ₁	B ₂	B ₃	H ₁	H ₂	H ₃	H ₄	A	A ₁	A ₂	D	D ₁	D ₂	d			
VKS 1/16	A80V4	1.5	24 (1450)	762	525	109	255	315	220	78	140	203	108	443	221	336	240	190	75	60	25				
	5A80MV4																								
	AIR80V4																								
	ADM80V4																								
	5A80MV4-OM2																								
	AIR80V4-OM2																								
VKS 2/26	AIR100L6	2.2	16 (970)	840																					
	A100L6			870	580											379									
	ADM100L6			840																					
	A100S4	3	24 (1450)	825																					
	AIR100S4			808	555	102		300	240		198		448			365	250								
	ADM100S4																								
	AIR100L4	4	24 (1450)	840																					
	A100L4			868	580		262		100	155		107		220		379	192	100	80	40					
	ADM100L4			840																					
	5A100L4OM2	5.5	24 (1450)	930																					
	A112M4																								
	AIR112M4			888	630	109		290	250				203		453		413	240							
	ADM112M4																								
	AIRM112M4			890																					
5AM112M4																									

* Model unit. Unit constructed on base plate.

OVERALL DIMENSIONS

model		el. motor power, kW	rotation speed, s ⁻¹ (rpm)	dimensions in mm																				
A*	electric motor			L	L ₁	L ₂	L ₄	B	B ₁	B ₂	B ₃	H ₁	H ₂	H ₃	H ₄	A	A ₁	A ₂	D	D ₁	D ₂	d		
VKS 4/28	AIR112M4	5.5	24 (1450)	895																				
	5AM112M4			942	630	109		290				203		449		413								
	A112M4			937																				
	ADM112M4	905				269		245	100	160		110		223					100	80	40			
	A132S4	967																						
	AIRM132S4	922		640	102									456										
VKS5/24; VKS5/32	AIRM132S4	7.5	24 (1450)	925													432	240	195					
	A132S4			928	640		300				210													
	AIRM132M4	11		966		102	275		258	108	162		115	464	228					110	90	50		
	A132M4			973	680											451								
VKS 10/45	AIR160M4	18.5	24 (1450)	1167				331					242		547									
	5A160M4			1207	780														290					
	AIR180S4	22		1137																				
	A180S4			1152	777	97	297		350	125	215		121		261	560		205	130	110	65			
	AIR180M4	30		1187				356					262		567		315							
	4AMH180S4			1087	815																			
A180M4		1212																						

model		el. motor power, kW	rotation speed, s ⁻¹ (rpm)	dimensions in mm																				
A*	electric motor			L	L ₁	L ₂	L ₃ *	L ₄	B	B ₁	B ₂	H	H ₁	H ₂	A	A ₁	A ₂	A ₃	D	D ₁	D ₂	d	R	
VKO 1/16	A80V4	1.5	24 (1450)																					
	5A80MV4																							
	AIR80V4			765	525	109	355	260	315	220	78	333	203	108	336	240				75	60	25		
	ADM80V4																							
	5A80MV4-OM2																							
	AIR80V4-OM2																							
VKO 2/26	AIR100L6	2.2	24 (1450)	860									344											
	A100L6			890	580										370									
	ADM100L6			860											344									
	A100S4	3		845										328										
	AIR100S4			830	555	102	433		300	240			198		365	250	190	30						
	ADM100S4																							
	AIR100L4	4		860										344										
	A100L4			890	580		284				100		107		379				100	80	40			
	ADM100L4			860																				
	5A100L4-OM2																							
	A112M4	5.5		951											388									
	AIR112M4														363									
	ADM112M4			910	630	109	497		290	250				203	413	240								
	AIRM112M4															376								
5AM112M4														371										
			950																					

* Model unit. Unit constructed on base plate.

OVERALL DIMENSIONS

model		el. motor power, kW	rotation speed, s ⁻¹ (rpm)	dimensions in mm																					
A*	electric motor			L	L ₁	L ₂	L ₃	L ₄	B	B ₁	B ₂	H	H ₁	H ₂	A	A ₁	A ₂	A ₃	D	D ₁	D ₂	d	R		
VKO 4/28	AIR112M4	5.5	24 (1450)	915																					
	5AM112M4			962	630	109	477		290																
	A112M4			957																					
	ADM112M4			915				290		245	100	366		110						100	80	40		72	
	A132S4	987																							
	AIRM132S4	942		7.5			529																		
AIR132S4	945	640												432	240	196	30								
AIRM132S4	948				102			300							210										
VKO5/24; VKO5/32	A132S4	7.5																							
	AIRM132M4			986			541	296		258	108	403		115					110	90	50				
	A132M4	11		993																					
	AIRM132M4			993	680										451										
VKO 10/45	AIR160M4	18.5																							
	5A160M4			1196	780				331																
	AIR180S4	22		1236			690																		
	A180S4			1166	777	97		325		350	125	507		121	560		213	60	130	110	65			87	
	AIR180M4			1181																					
	4AMH180S4	30		1216					356							315									
	A180M4			1116	815		735																		
				1241																					

* Model unit. Unit constructed on base plate.

CENTRIFUGAL VORTEX PUMPS OF CVK TYPE

APPLICATION

Pumps **CVK** and units on their basis are intended for pumping of water and other neutral liquids with the kinematic viscosity up to $36 \times 10^{-6} \text{ m}^2/\text{s}$ (36 cSt), density of not more than $1200 \text{ kg}/\text{m}^3$, with the content of solid particles not more than 0.01% by weight and the size of particles not more than 0.05 mm.

The pumped water temperature is from -15 to $+105 \text{ }^\circ\text{C}$.

The pumps are manufactured in climatic version U3.1 and T2 under GOST 15150-69.

The unit location category is determined according to the motor. The pumps are not to be used for pumping of flammable and highly-inflammable liquids.

The units are manufactured in general industrial version and in version for explosion and fire hazardous industries.

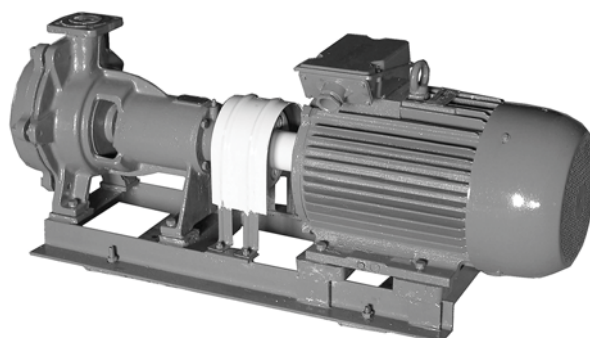

PUMP TYPE KEY

Example of designation:

CVK 6.3/120 U3.1 TU26-06-1280-87

CVK XX / XXX U3.1

centrifugal-vortex

capacity, l/s

head, m

climatic version and location category

TECHNICAL PARAMETERS			
parameter	CVK 4/112	CVK 5/125	CVK 6.3/160
capacity l/s (m ³ /h)	4(14.4)	5(18)	6.3 (22.7)
head, m	112	125	160
rotating speed s ⁻¹ (rpm)	49 (2950)	49 (2950)	49 (2950)
net positive suction head, m, max	2.6	2.8	3.0
pump inlet pressure, MPa (kgf/cm ²) max	0.25 (2.5)	0.25 (2.5)	0.25 (2.5)
pump outlet pressure, MPa (kgf/cm ²)	2.05 (20.5)	2.08 (20.8)	2.15(21.5)
pump power, kW, max	17	21	29
pump efficiency, %	0.40(40)	0.43(43)	0.44(44)
power supply	current	alternating	
	voltage, V	220, 380, 660	
	frequency, Hz	50	

PERFORMANCE CURVE

CVK 4/112 * – pump data
 rotation speed 49 s^{-1} (2950 rpm)
 liquid – water (20 °C), density 1000 kg/m^3

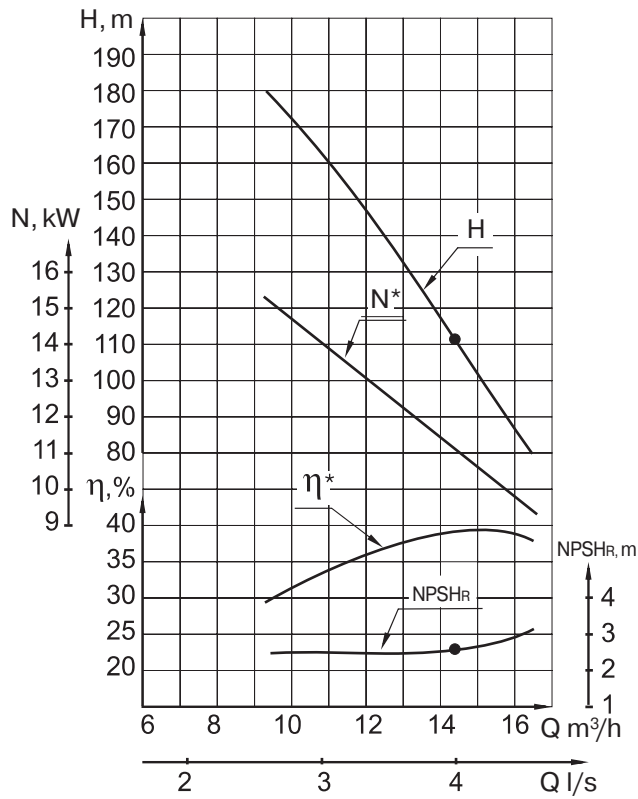

CVK 5/125 * – pump data
 rotation speed 49 s^{-1} (2950 rpm)
 liquid – water (20 °C), density 1000 kg/m^3

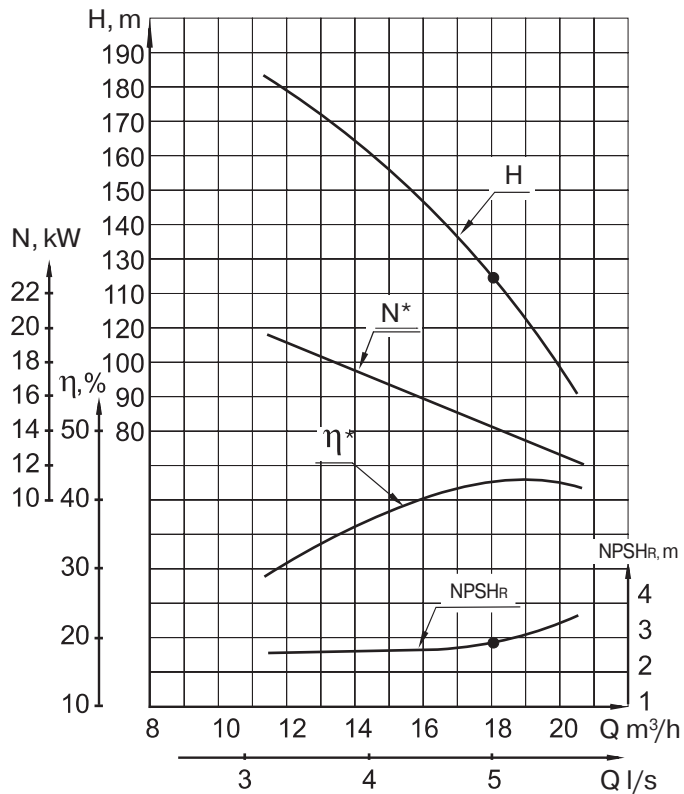

PERFORMANCE CURVE

CVK 6.3/160 * – pump data
 rotation speed 49 s^{-1} (2950 rpm)
 liquid – water (20 °C), density 1000 kg/m^3

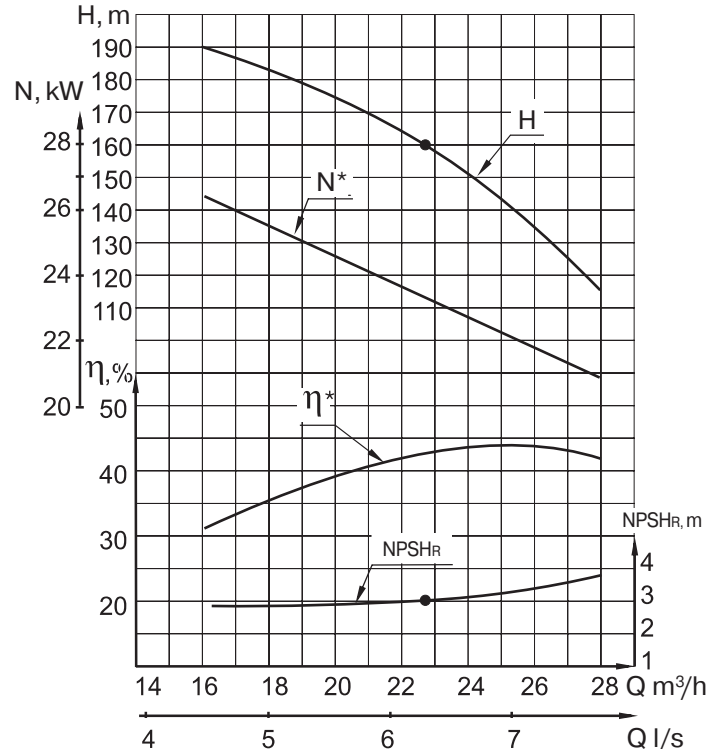

PUMP OVERALL DIMENSIONS

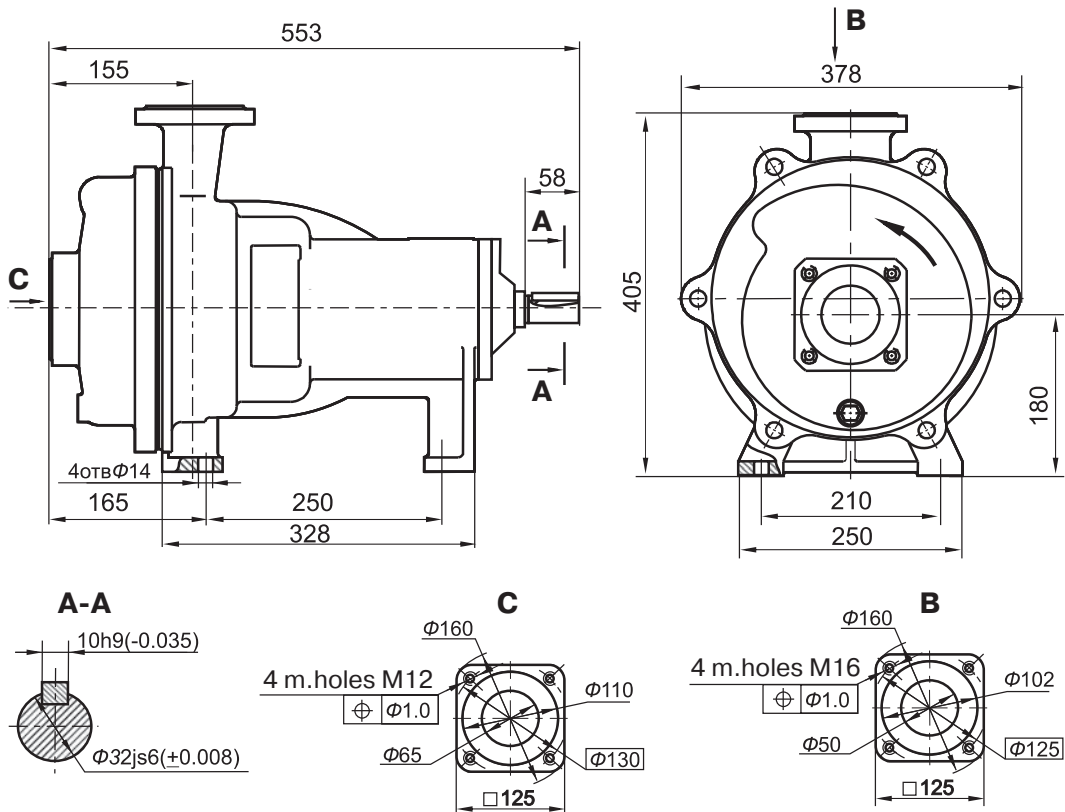

UNIT OVERALL DIMENSIONS & TECHNICAL PARAMETERS

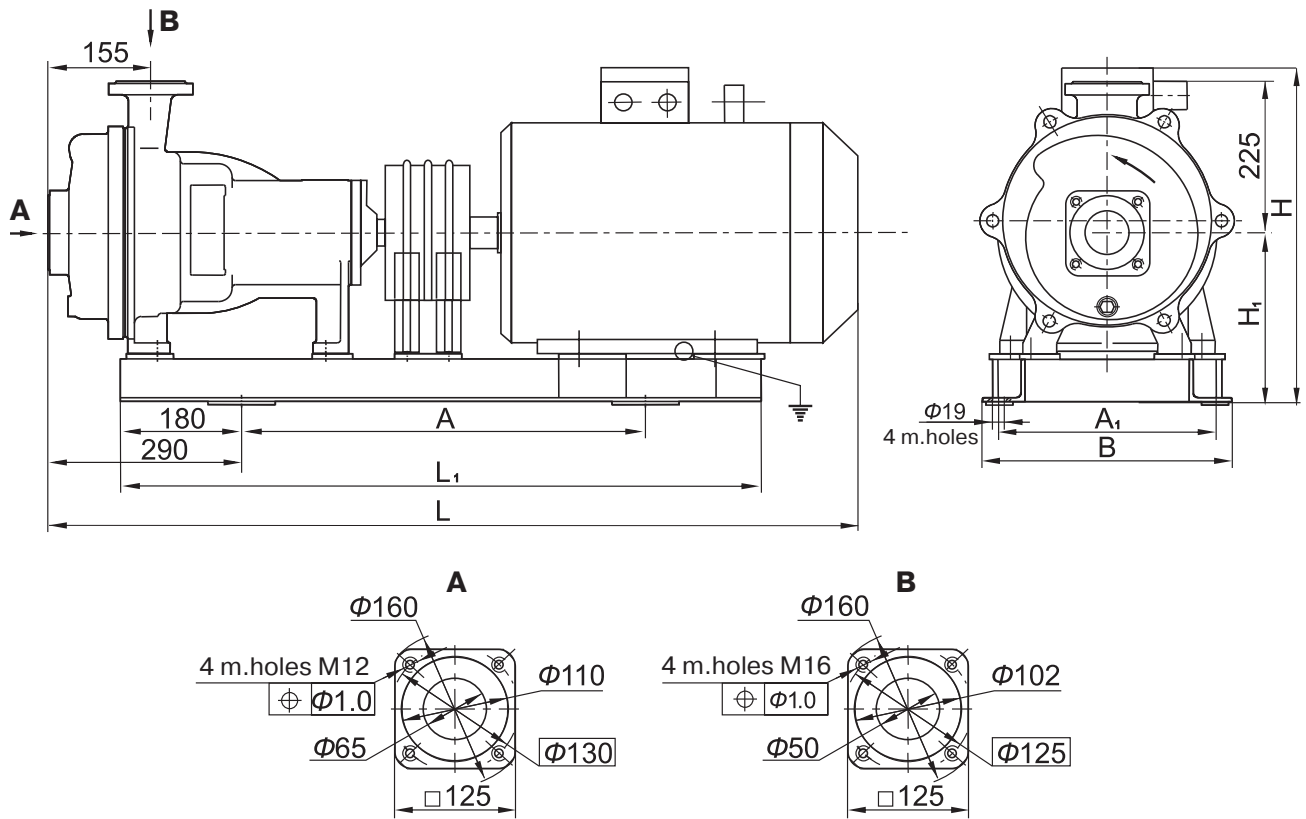

unit model	electric motor model	power, kW	rotation speed, s ⁻¹ (rpm)	dimensions in mm							weight, kg					
				L	L ₁	B	H	H ₁	A	A ₁						
CVK 4/112	AIR160M2	18,5	50 (3000)	1205		400	500	160		336	220					
	5A160M2			1260			500				245					
	VA160M2			1230			615				270					
	AIMR160M2			1290			590				270					
CVK 4/112 CVK 5/125	AIP180S2	22		1190	970	370	515	180	600	320	265					
	A180S2			1205			500				252					
	VA180S2			1205			575				285					
	AIMP180S2			1260			610				325					
CVK 5/125 CVK 6,3/160	AIR180M2	30		1240							406	515	200	640	360	285
	A180M2			1265								500				275
	VA180M2			1265								575				305
	AIMP180M2			1305								610				345
CVK 6.3/160	4AMN180S2	37	1140	1000	406	475	200	640	360	275						
	5A200M2		1295			560				345						
	A200M2		1365			550				340						
	VA200M2		1325			635				415						

CENTRIFUGAL CANTILEVER PUMPS OF SM TYPE AND ELECTRIC PUMP UNITS ON THEIR BASIS

APPLICATION

Centrifugal pumps of **SM** type are intended for pumping city and industrial waste waters and other non-aggressive liquids with the density up to 1050 kg/m^3 , with $\text{pH}=6-8.5$, with the temperature up to 80°C , and the content of abrasive particles not more than 1% by weight, with the size of up to 5 mm. The limit concentration of the pumped mass is 2%. The limit gas content in the pumped media is 5%. The pumps may be use in other industries if their parameters and versions comply with the operating and safety conditions of such industries.

The pumps (units) are manufactured in climatic version UHL, T location category 3.1,2 under GOST 15150-69.

The pumps of SM type and electric pump units on their basis (hereinafter referred to as the units) are not intended for use in explosion and fire hazardous premises.

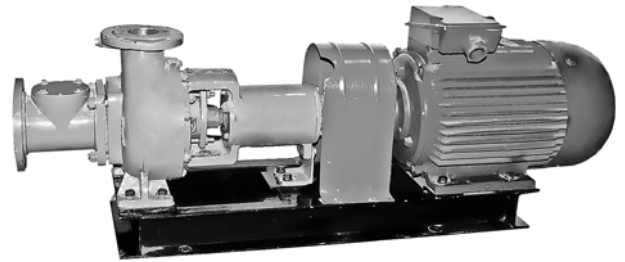

PERFORMANCE RANGE

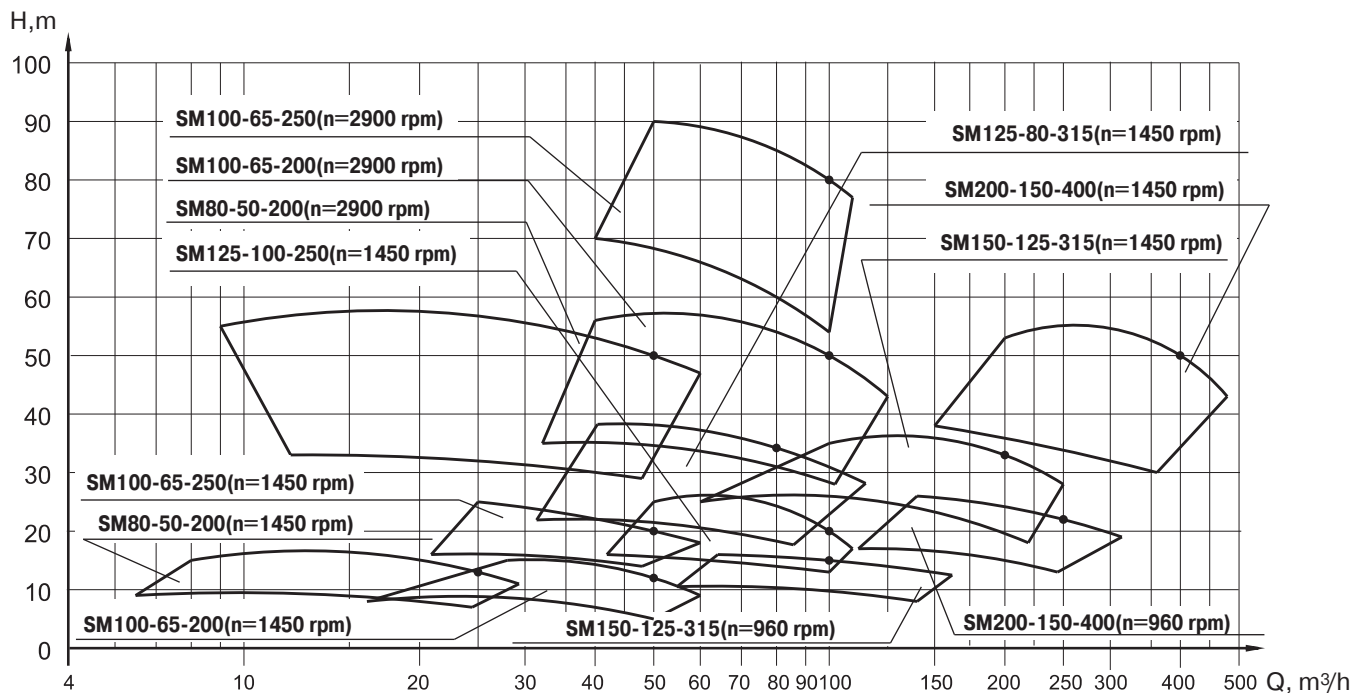

PUMP TYPE KEY

Example of designation:

SM 150-125-315-6 UHL4 TU26-06-1672-95

SM XXX - XXX - XXX - X УХЛХ

waste water

inlet diameter

outlet diameter

impeller diameter: **a, b** - decreased diameter

designation of rotating speed:

2 - 48.4 s⁻¹ (2900 rpm), **4** - 24.2 s⁻¹ (1450 rpm), **6** - 16.0 s⁻¹ (960 rpm)

climatic version and location category

TECHNICAL PARAMETERS

unit model	capacity, m ³ /h	head, m	rotating speed, rpm	consumed power, kW
SM80-50-200-2	50	50	2900	14.6
SM80-50-200a-2	45	42	2900	10.2
SM80-50-200b-2	25	32	2900	8.6
SM80-50-200-4	25	12.5	1450	2.2
SM80-50-200a-4	22	9	1450	1.7
SM80-50-200b-4	20	7.5	1450	1.2
SM100-65-200-2	100	50	2900	27
SM100-65-200a-2	100	32	2900	20.1
SM100-65-200b-2	80	32	2900	15
SM100-65-200-4	50	12.5	1450	3.5
SM100-65-200a-4	45	9	1450	2.6
SM100-65-200b-4	40	8	1450	2
SM100-65-250-2	100	80	2900	42
SM100-65-250a-2	90	70	2900	35
SM100-65-250b-2	80	60	2900	27
SM100-65-250-4	50	20	1450	6
SM100-65-250a-4	45	16	1450	4.4
SM100-65-250b-4	40	15	1450	4
SM125-100-250-4	100	20	1450	11.2
SM125-100-250a-4	100	15	1450	8.2
SM125-100-250b-4	80	14	1450	6.8
SM150-125-315-4	200	32	1450	29
SM150-125-315a-4	180	27.5	1450	24
SM150-125-315b-4	160	22.5	1450	19
SM150-125-315-6	100	15	960	9.6
SM150-125-315a-6	100	12.5	960	8.5
SM150-125-315b-6	92	10	960	6.9
SM200-150-400-4	400	50	1450	98
SM200-150-400a-4	300	40	1450	70.2
SM200-150-400b-4	300	32	1450	53
SM200-150-400-6	250	22.5	960	28
SM200-150-400a-6	220	17	960	21
SM200-150-400b-6	200	14	960	15.5
SM125-80-315-4	80	32	1450	15
SM125-80-315a-4	72	26	1450	13.2
SM125-80-315b-4	65	20	1450	11.2

PERFORMANCE CURVE

SM 80-50-200-4

rotation speed 24.2 s^{-1} (1450 rpm)
liquid – water (20 °C), density 1000 kg/m^3

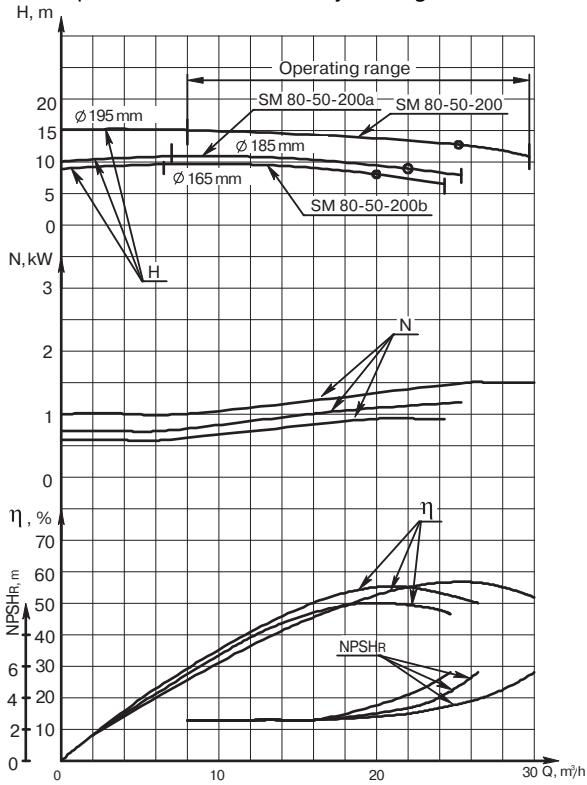

SM 80-50-200-2

rotation speed 48.4 s^{-1} (2900 rpm)
liquid – water (20 °C), density 1000 kg/m^3

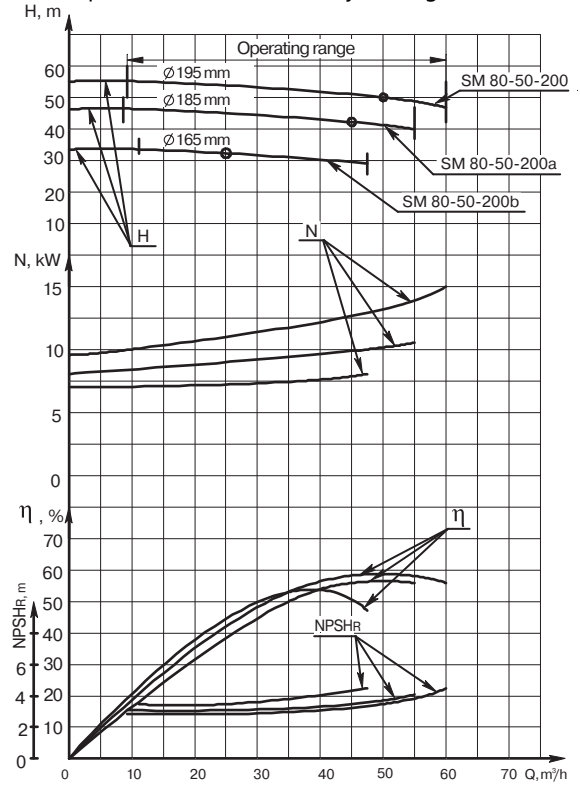

SM 100-65-200-4

rotation speed 24.2 s^{-1} (1450 rpm)
liquid – water (20 °C), density 1000 kg/m^3

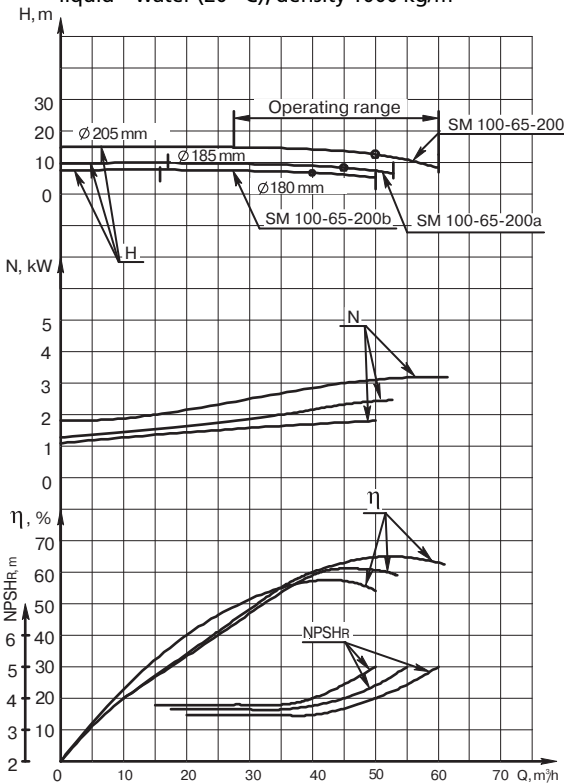

SM 100-65-200-2

rotation speed 48.4 s^{-1} (2900 rpm)
liquid – water (20 °C), density 1000 kg/m^3

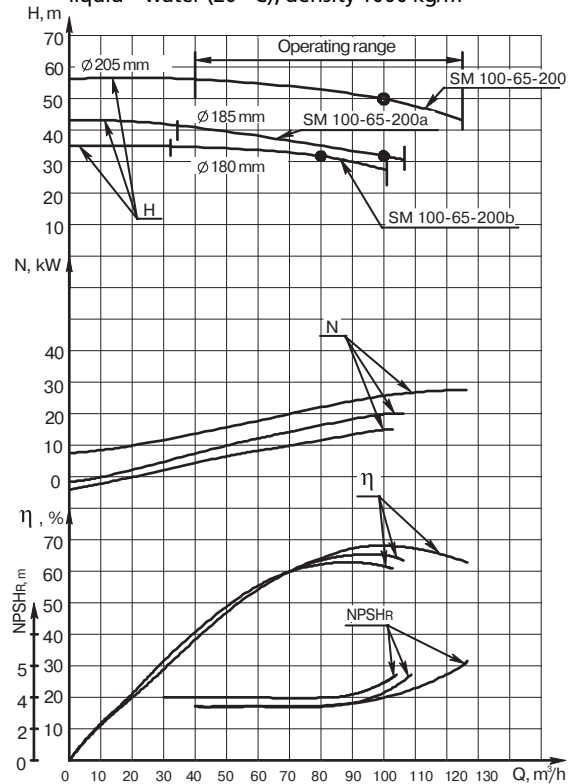

PERFORMANCE CURVE

SM 100-65-250-4

rotation speed 24.2 s^{-1} (1450 rpm)

liquid – water (20 °C), density 1000 kg/m^3

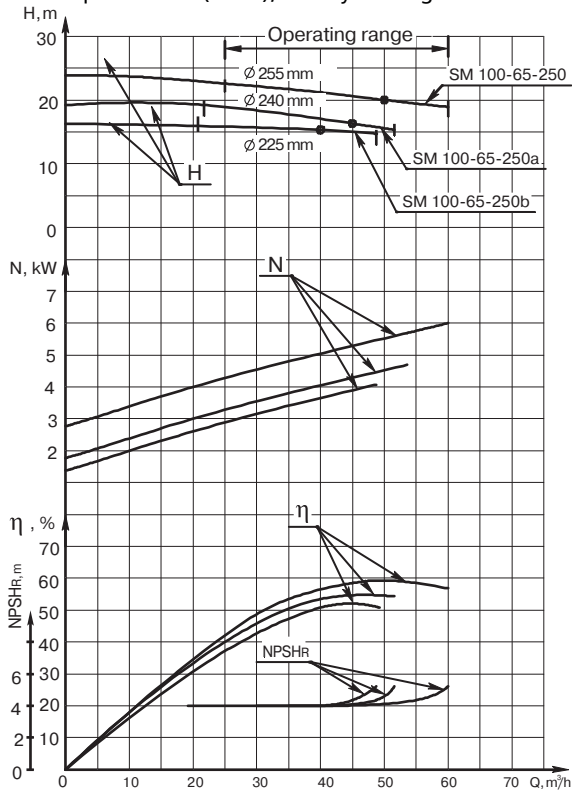

SM 100-65-250-2

rotation speed 48.4 s^{-1} (2900 rpm)

liquid – water (20 °C), density 1000 kg/m^3

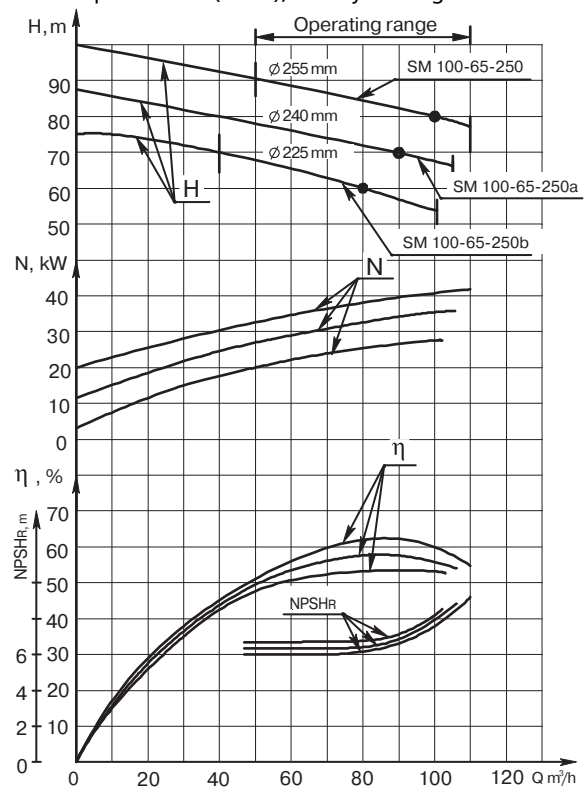

SM 125-80-315-4

rotation speed 24.2 s^{-1} (1450 rpm)

liquid – water (20 °C), density 1000 kg/m^3

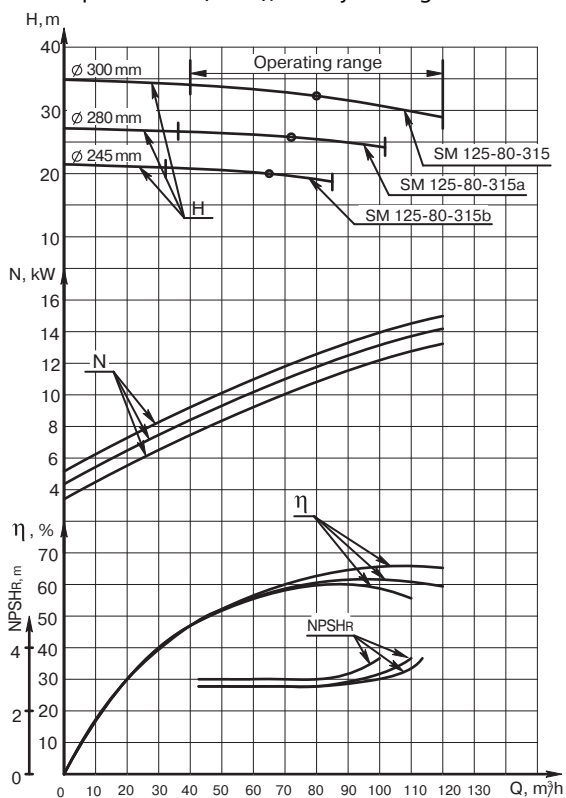

SM 125-100-250-4

rotation speed 24.2 s^{-1} (1450 rpm)

liquid – water (20 °C), density 1000 kg/m^3

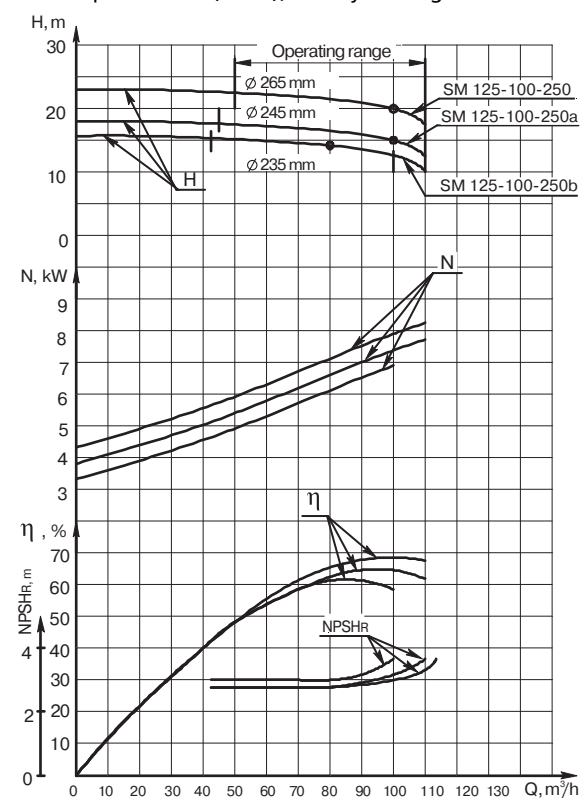

PERFORMANCE CURVE

SM 150-125-315-6

rotation speed 16 s^{-1} (960 rpm)

liquid – water (20 °C), density 1000 kg/m^3

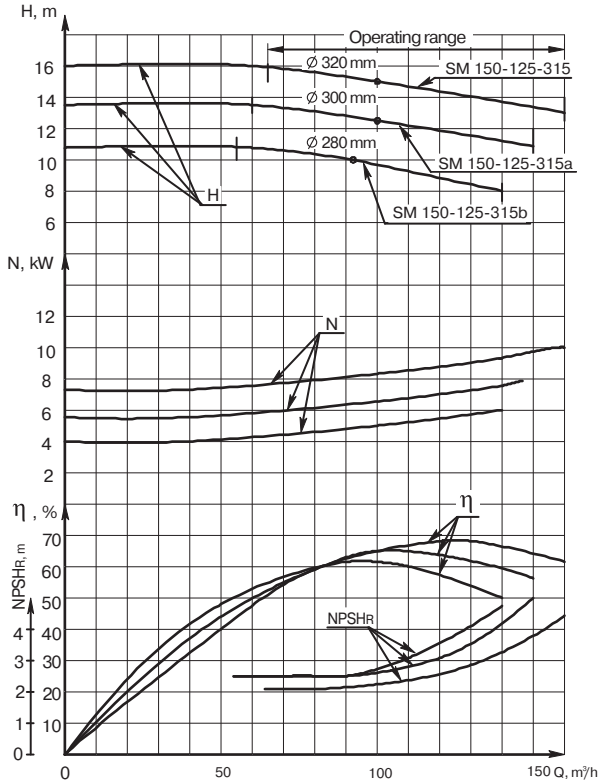

SM 150-125-315-4

rotation speed 24.2 s^{-1} (1450 rpm)

liquid – water (20 °C), density 1000 kg/m^3

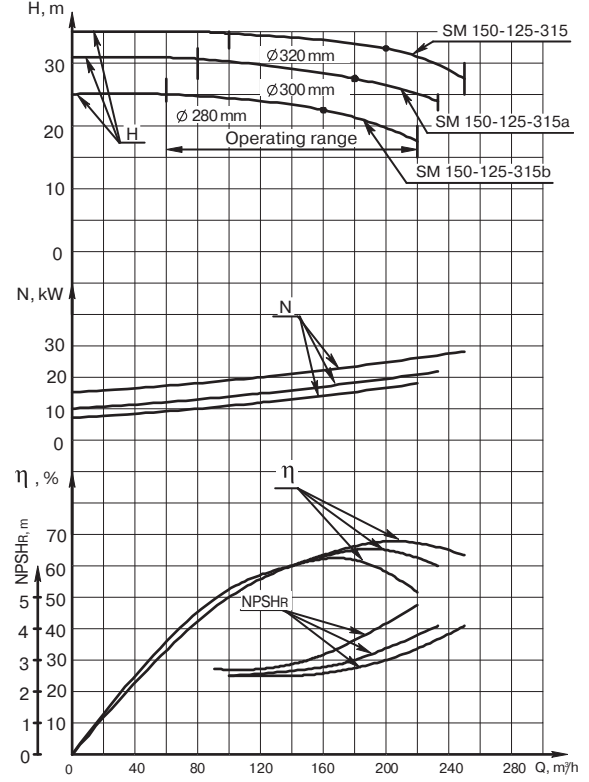

SM 200-150-400-6

rotation speed 16 s^{-1} (960 rpm)

liquid – water (20 °C), density 1000 kg/m^3

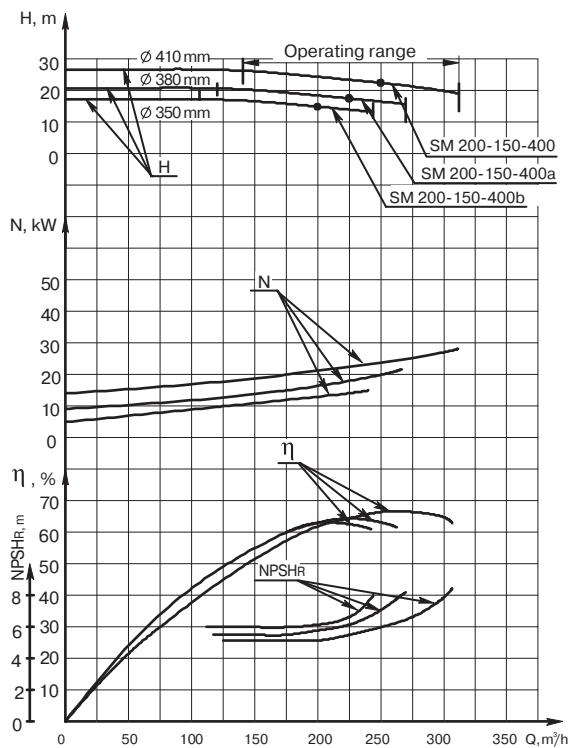

SM 200-150-400-4

rotation speed 24.2 s^{-1} (1450 rpm)

liquid – water (20 °C), density 1000 kg/m^3

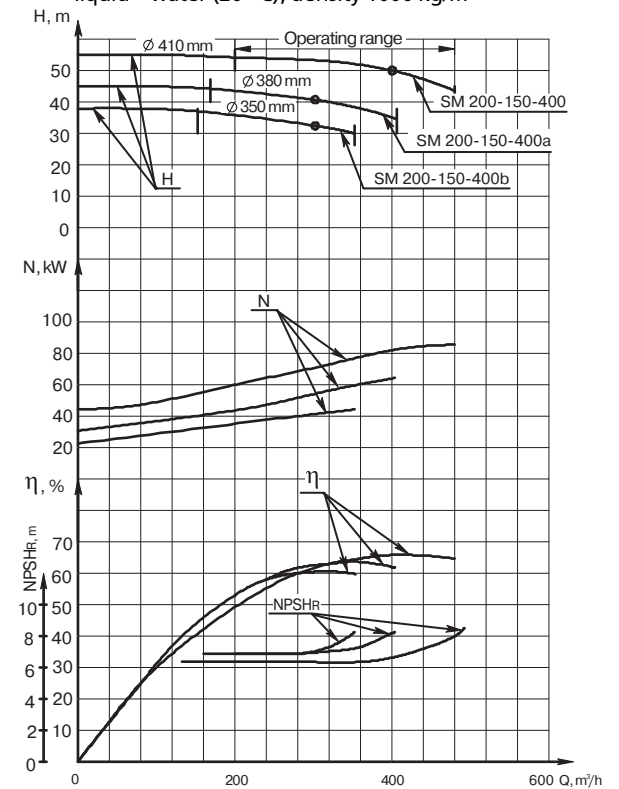

PUMP OVERALL DIMENSIONS

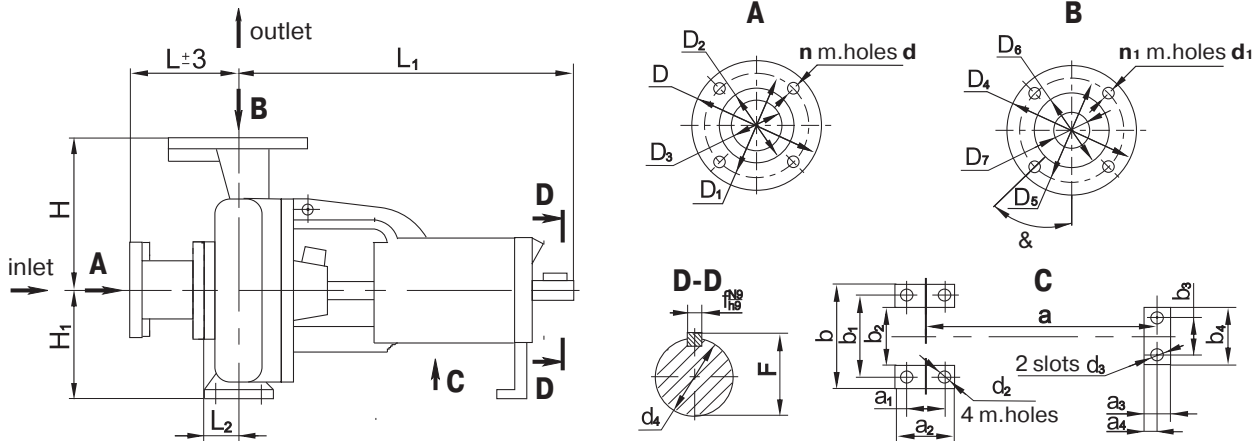

value	dimensions in mm							
	pump models							
	80-50-200	100-65-200	100-65-250	125-100-250	150-125-315	200-150-400	125-80-315	
inlet conditional diameter, D_3	80	100	100	125	150	200	125	
outlet conditional diameter, D_7	50	65	65	100	125	150	80	
impeller conditional diameter	base	195	205	255	265	320	410	300
	a	185	185	240	245	300	380	280
	b	165	180	225	235	280	350	270
L	167	276	292	200	395	310	320	
L_1	500	500	520	550	560	765	550	
L_2	75	75	90	91	115	160	102	
H	225±1	250±1	250±0,5	280	355	450	315	
H_1	180±1	180±1	200±0,5	225±0,5	280	315	225	
D	185	205	215	245	280	335	245	
D_1	150	170	180	210	240	295	210	
D_2	128	148	158	184	212	268	184	
D_4	160	180	180	215	245	280	195	
D_5	125	145	145	180	210	240	160	
D_6	102	122	122	158	184	212	133	
d	18	18	18	18	22	22	18	
n	4	4	8	8	8	8	8	
d_1	M16-6N	M16-6N	M16-7N	M16-7N	M16-7N	M20-7N	18	
n_1	4	4	4	8	8	8	4	
a	370	370	370	370	370	500	370	
a_1	95	95	120	120	150	150	120	
a_2	125	125	160	160	200	200	160	
a_3	45	45	70	70	70	80	70	
a_4	16	16	30	30	30	40	30	
b	320	320	360	400	480	500	400	
b_1	250	250	315	315	400	400	315	
b_2	180	180	200	240	300	300	240	
b_3	110	110	110	110	110	140	110	
b_4	145	145	145	160	160	200	160	
d_2	14	14	18	18	24	24	18,5	
d_3	14	14	14	14	18	18,5	14	
d_4	32h7 _(-0.025)	32h7 _(-0.025)	42h7 _(-0.025)	42js6(±0.008)	42h7 _(-0.025)	48h7 _(-0.025)	42h7 _(-0.025)	
f	10 ^{$\frac{-0.036}{-0.036}$}	10 ^{$\frac{-0.036}{-0.036}$}	12 ^{$\frac{-0.043}{-0.043}$}	10 ^{$\frac{-0.036}{-0.036}$}	10 ^{$\frac{-0.036}{-0.036}$}	14 ^{$\frac{-0.043}{-0.043}$}	10 ^{$\frac{-0.036}{-0.036}$}	
F	35	35	45	45	45	54	45	
&	45°	45°	45°	22° 30'	22° 30'	22° 30'	45°	
weight, kg. with reducing sleeve	75	74	120,5	115	210	320	138	
weight, kg. without reducing sleeve	62	60	105	100	175	290	111	

UNIT OVERALL DIMENSIONS

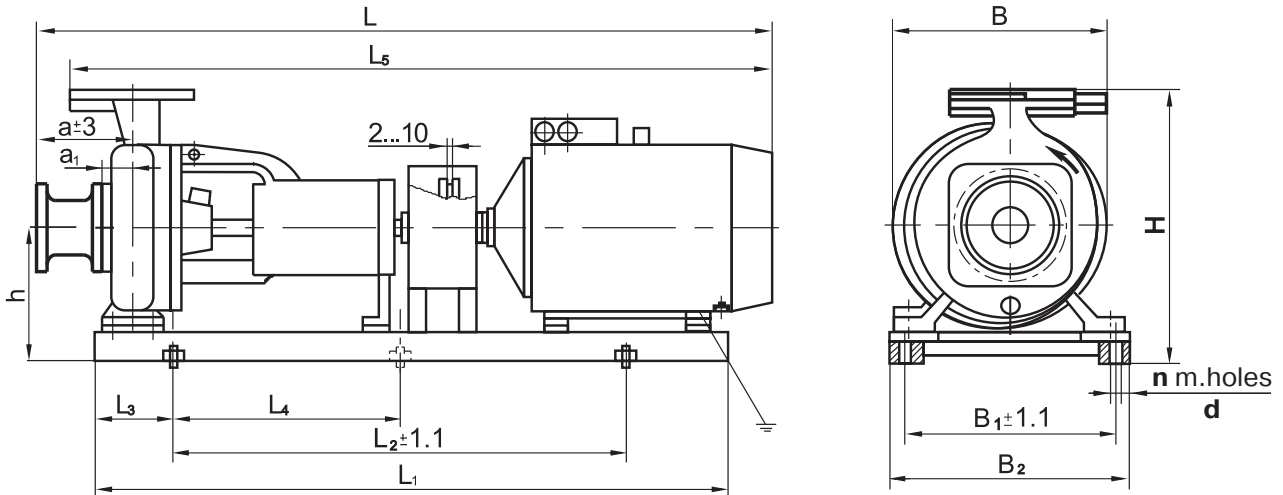

unit model	electric motor model	el. motor power, kW	rotation speed, s ⁻¹ (rpm)	dimensions in mm													weight, kg	
				a (a ₁)	L	L ₁	L ₂	L ₃	L ₄	L ₅	B	B ₁	B ₂	H	h	n		d
SM80-50-200-2	5A160S2	15	48.4 (2900)	167 (75)	1350	1085	840	100	420	1258	350	240	282	535	310	6	19	260
SM80-50-200a-2	AIRM132M2	11			1170	975				1083								550
SM80-50-200b-2	AIRM132M2	11	24.2 (1450)	167 (75)	1060	875	620	150	-	978	316	240	282	535	310	4	19	155
SM80-50-200-4	AIP100L4	4			1050					948								145
SM80-50-200a-4	A100S4	3	48.4 (2900)	276 (75)	1520	1200	960	140	480	1334	300	344	640	355	6	19	387	
SM80-50-200b-4	A100S4	3			1420	1085				840							100	420
SM100-65-200-2	5A200M2	37	48.4 (2900)	276 (75)	1485	1085	840	100	420	1304	360	240	282	565	310	4	19	270
SM100-65-200a-2	AIP180S2	22			1265					925								620
SM100-65-200b-2	5A160M2	18.5	24.2 (1450)	276 (75)	1160	875	620	150	-	959	360	240	282	565	310	4	19	146
SM100-65-200a-4	A100S4	3			1600	1200				960								140
SM100-65-200b-4	A100S4	3	48.4 (2900)	292 (90)	1555	1200	960	140	480	1358	300	344	640	355	6	19	430	
SM100-65-250-2	5A200L2	45			1500					1150							1298	410
SM100-65-250a-2	5A200M2	37	24.2 (1450)	292 (90)	1280	1000	700	200	-	1078	315	347	585	335	4	19	250	
SM100-65-250b-2	AIR180M2	30			1300	950				1098							315	347
SM100-65-250-4	AIPM132S4	7.5	24.2 (1450)	292 (90)	1240	950	700	200	-	1008	410	315	347	585	335	4	19	210
SM100-65-250a-4	5AM112M4	5.5			1425	1085				1333								305
SM100-65-250b-4	A100L4	4	48.4 (2900)	200 (91)	1255	1035	840	150	420	1160	415	290	342	640	6	19	265	
SM125-100-250-4	5A160S4	15			1215	1123				250								
SM125-80-315-4	5A160M4	18.5	24.2 (1450)	320 (102)	1575	1115	630	250	-	1353	420	320	362	680	4	19	348	
SM125-80-315a-4	5A160S4	15.0			1545	1085				1323							332	
SM125-80-315b-4	5A160S4	15.0	48.4 (2900)	395 (115)	1730	1317	1000	500	1423	536	400	445	790	435	6	19	548	
SM150-125-315-4	5A200M4	37.0			1645	1197											900	450
SM150-125-315a-4	AIR180M4	30.0	24.2 (1450)	395 (115)	1595	1197	900	150	1318	536	400	445	790	435	6	19	468	
SM150-125-315b-4	AIR180S4	22.0			1635												1162	850
SM150-125-315-6	5A160S6	11.0	16.3 (960)	395 (115)	1635	1162	850	425	1358	536	400	445	790	435	6	19	423	
SM150-125-315a-6	5A160S6	11.0			1465	1065											1188	375
SM150-125-315b-6	AIRM132M6	7.5	24.2 (1450)	313 (160)	2200	1735	300	550	2027	580	520	580	970	515	6	19	1230	
SM200-150-400-4	5AM280S4	110.0			2050	1650			1877								580	520
SM200-150-400a-4	5AM250M4	90.0	16.3 (960)	313 (160)	2020	1600	1100	230	1847	660	400	448	970	475	33	19	930	
SM200-150-400b-4	5AM250S4	75.0			1900	1550			1722								705	
SM200-150-400-6	5A200L6	30.0	16.3 (960)	313 (160)	1850	1770	1400	160	1672	660	400	448	970	475	33	19	690	
SM200-150-400a-6	5A200M6	22.0			1586				605									
SM200-150-400b-6	AIR180M6	18.5																

VORTEX PUMPS OF SMS TYPE AND ELECTRIC PUMP UNITS ON THEIR BASIS

APPLICATION

Vortex pumps of **SMS** type and electric pump units on their basis are intended for pumping municipal and industrial waste waters and other nonaggressive liquids with the density up to 1050 kg/m³, with pH=5-10, with the temperature up to 90 °C and the content of abrasive particles not more than 1% by weight with the size of up to 5 mm. The limit concentration of the pumped mass is 8%. The limit gas content in the pumped media is 5%. The pumps may be used in other industries if their parameters and versions comply with the operating and safety conditions of such industries.

The pumps (units) are manufactured in climatic version UHL, T for operation in premises of location category 4.2 under GOST 15150.

The pumps (units) are not intended for use in explosion and fire hazardous premises.

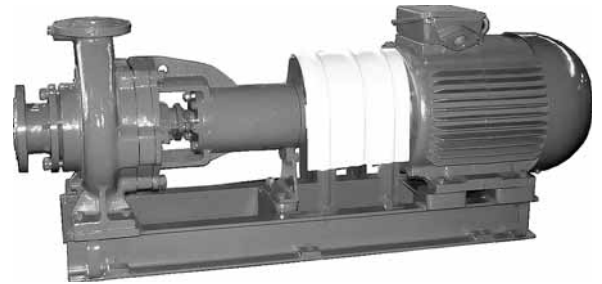

PUMP TYPE KEY

Example of designation:
SMS 150-125-315 UHL4

waste-water torque-flow (free-vortex)

inlet diameter, mm

outlet diameter, mm

impeller diameter (nominal), mm

climatic version and location category

SMS XXX - XXX - XXX UHLX

TECHNICAL PARAMETERS										
pump (unit) model	capacity, Q		head, m	rotating speed		outlet pressure, max		power supply		
	m ³ /s	m ³ /h		s ⁻¹	rpm	MPa	kgf/cm ²	current	voltage, V	frequency, Hz
SMS 80-50-200	0.025	90	60	48.3	2900	0.25	2.5	alternating	220/380	50
SMS 150-125-315	0.058	200	32	24.2	1450	0.25	2.5			

The values of the major parameters are specified for pumping of water with the temperature of 293K (20 °C) and density 1000 kg/m³

TECHNICAL PARAMETERS

pump (unit) model	flow passage size, mm	pump efficiency, %	net positive suction head, m	leakage through the sealing, m ³ /h (l/h), max	pump weight, kg		pump power, kW, max
					pump	unit	
SMS 80-50-200	50	54	5	3x10 ⁻³ (3.0)	75	413	35
SMS 150-125-315	75	57	7	3x10 ⁻³ (3.0)	250	662.5	46

PERFORMANCE CURVE

SMS 150-125-315

rotation speed 24.2 s⁻¹ (1450 rpm)

liquid – water (20 °C), density 1000 kg/m³

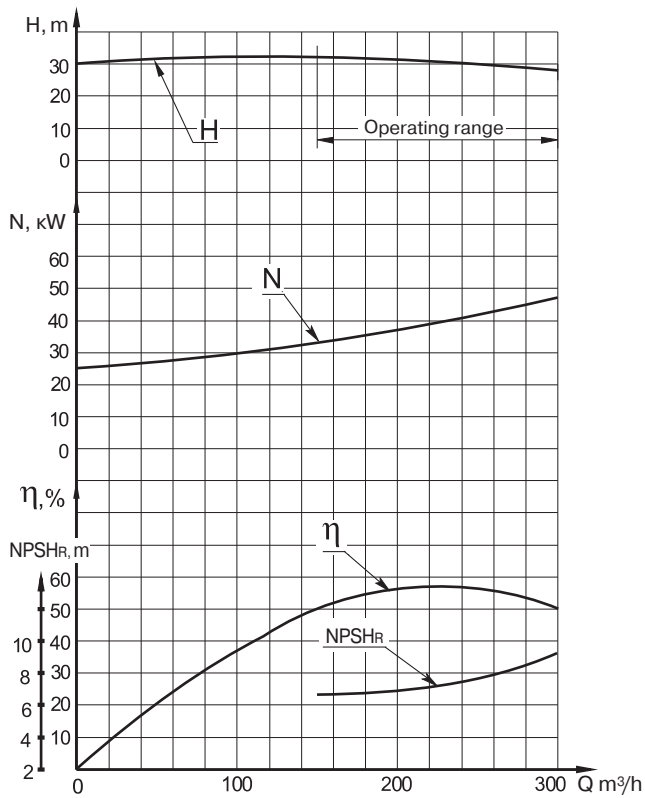

SMS 80-50-315

rotation speed 48.3 s⁻¹ (2900 rpm)

liquid – water (20 °C), density 1000 kg/m³

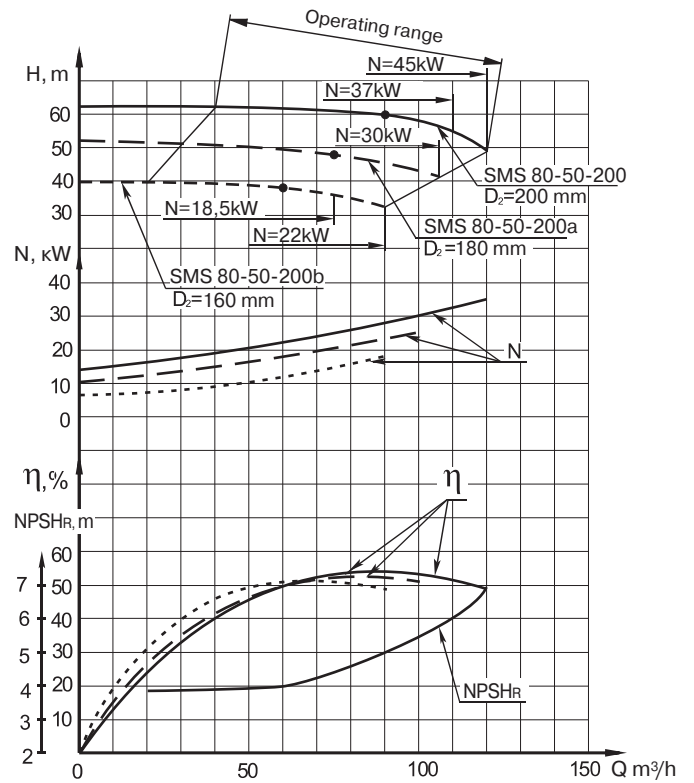

PUMP OVERALL DIMENSIONS

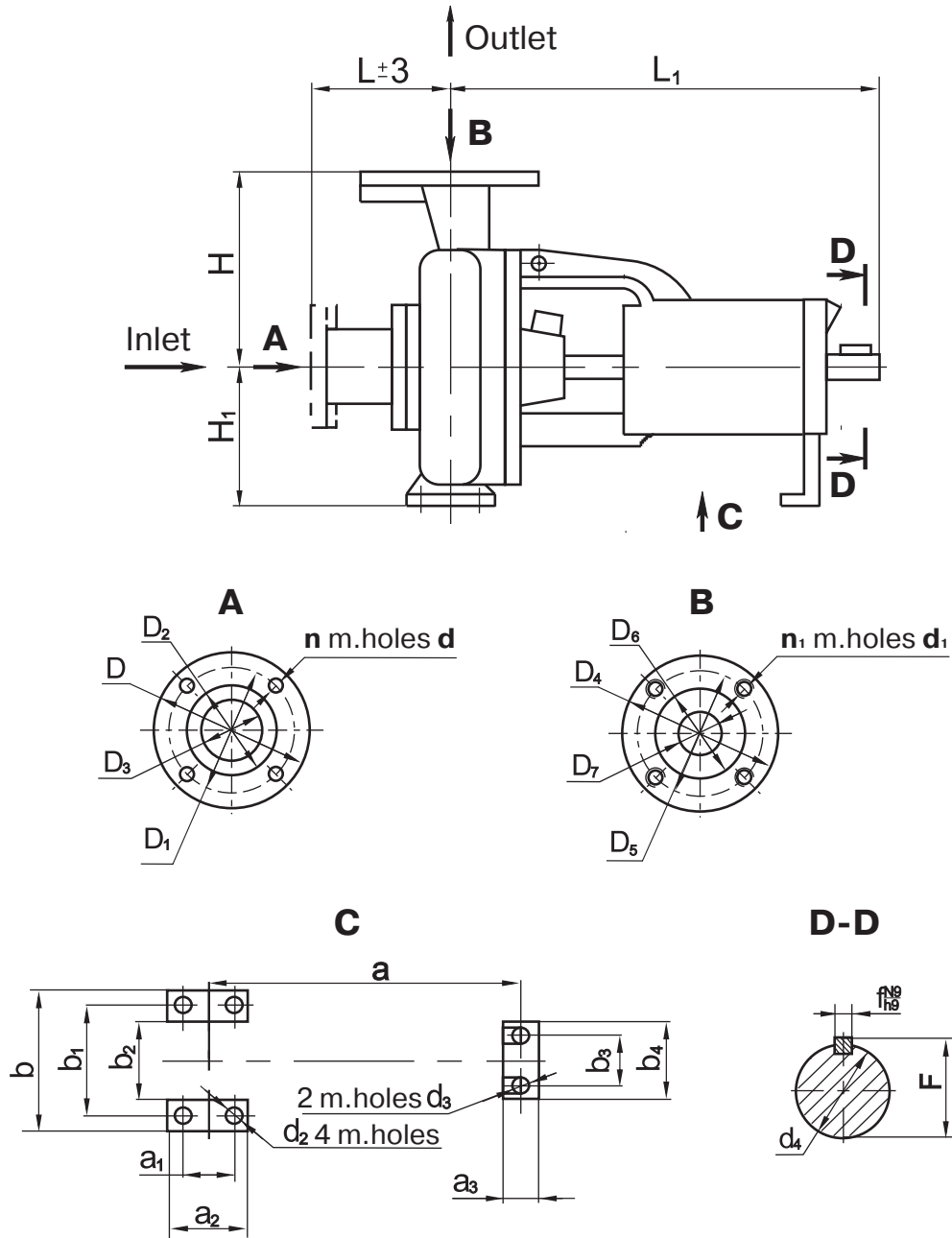

pump model	dimensions in mm																
	L	L ₁	H	H ₁	D	D ₁	D ₂	D ₃	D ₄	D ₅	D ₆	D ₇	d	d ₁	d ₂	d ₃	d ₄
SMS 80-50-200	165	532	225±1	180±1	185	150	128	80	160	125	102	50	18	M16	14	14	32h7
SMS 150-125-315	395	645	355	280	280	240	212	150	245	210	184	125	22	M16	24	16	42js6

pump model	dimensions in mm													weight, kg
	n	n ₁	a	a ₁	a ₂	a ₃	b	b ₁	b ₂	b ₃	b ₄	f	F	
SMS 80-50-200	4	4	403	95	125	45	320	250	190	110	145	10	35	75
SMS 150-125-315	8	8	440	150	200	70	480	400	310	110	160	10	45	250

UNIT OVERALL DIMENSIONS

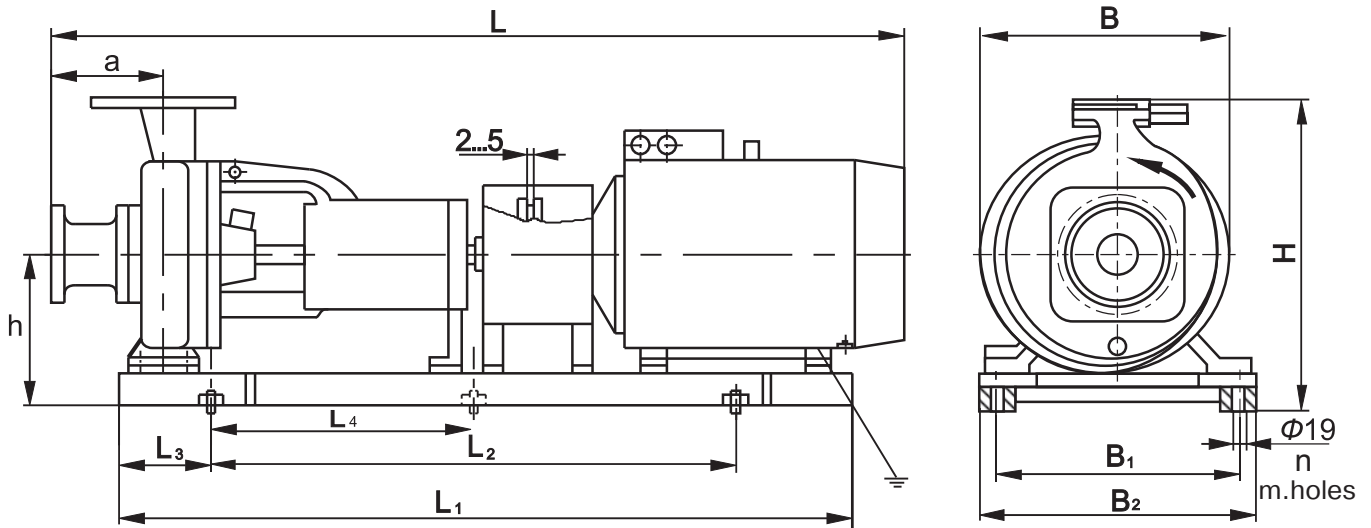

unit model	electric motor model	dimensions in mm											weight, kg	n
		L	L ₁	L ₂	L ₃	L ₄	H	B	B ₁	B ₂	a	h		
SMS 80-50-200	5A200L2 (45 kW)	1485					630						413	
	5A200M2 (37 kW)	1440					630					393		
SMS 80-50-200a	AIR180M2 (30 kW)	1385	1225	900±2	100	450±2	585		240±2	282	165	325	338	6
SMS 80-50-200b	AIR180S2 (22 kW)	1335					585						318	
	5A160M2 (18,5 kW)	1405					567						296	
SMS 150-125-315	5A225M4 (55 kW)	1910	1425	800	250	-	795	455	400	455	395	440	662.5	4

CENTRIFUGAL CLOSED-COUPLED SUBMERSIBLE ELECTRIC PUMPS OF CMF TYPE

APPLICATION

Electric pumps **CMF 50-25**, **CMF 160-80** are designed for use in drainage pumping stations and sanitary facilities of subways against order of «Petersburg Subway» in cooperation with MA «Metro» and «Moscow Subway».

Centrifugal single-block sanitary immersed electric pumps **CMF 50-25**, **CMF 160-80** are intended for pumping of utility and industrial waste waters. The pumps may also be used in agriculture for irrigation and drainage, in operation of hydraulic facilities in housing and utilities, for pumping of ground waters in industrial and civil construction.

- high reliability and durability in extreme operating conditions;
- low price as compared to the import and domestic analogs;
- simplicity of installation and operation;
- full short time reparability (about 1 hour needed for complete disassembly and assembly) using minimum general-purpose tools.

Pump section design makes it possible to pump liquids with high content of mechanical impurities (max size of nonabrasive particles is up to 8 mm).



Shaft sealing unit consists of two imported end seals combined in a common case, which makes it possible to change seals quickly and effectively in case of leakage.

The electric pumps are equipped with an integrated protection system including «dry» operation protection, thermal and moisture protection.

TECHNICAL PARAMETERS

parameter	value				
	CMF 50-25	CMF 50-25a	CMF 160-80	CMF 160-80a	CMF 160-80b
capacity, m ³ /h (l/s)	50 (13.89)		160 (44.45)	145 (40.28)	130 (36.11)
head, m	25	22	80	70	60
electric pump shaft power, kW	8,6		77.1		
rotating speed, s ⁻¹ (rpm)	48.3 (2900)				
allowable depth of submersible, m	7				
power supply	current	alternating			
	voltage	380			
	frequency, Hz	50			
efficiency, %	54		55		
hydraulic efficiency, %	70				
current, A, max	14,6		145		
weight, kg, max	90		345		
overall dimensions, mm	660x360x290		1000x780x390		

TECHNICAL PARAMETERS

parameter	CMF 50-25	CMF 160-80
pumped liquid maximum density, $\kappa\text{g/m}^3$	1250	
pumped liquid hydrogen index, pH	5-12	
maximum content of mechanical impurities by weight, %	10	
maximum size of mechanical particles, mm	8	8
maximal content of abrasive impurities by volume, %	1	
maximum size of abrasive particles, mm	5	5
pumped liquid maximum temperature, K ($^{\circ}\text{C}$)	308 (35)	

PERFORMANCE CURVE

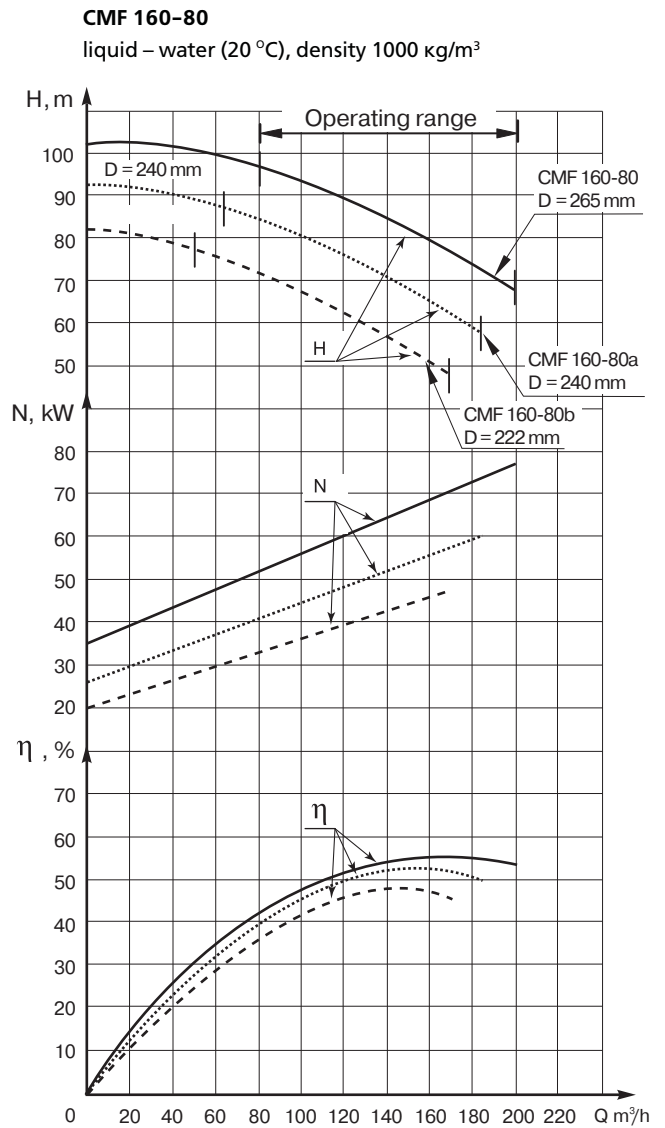
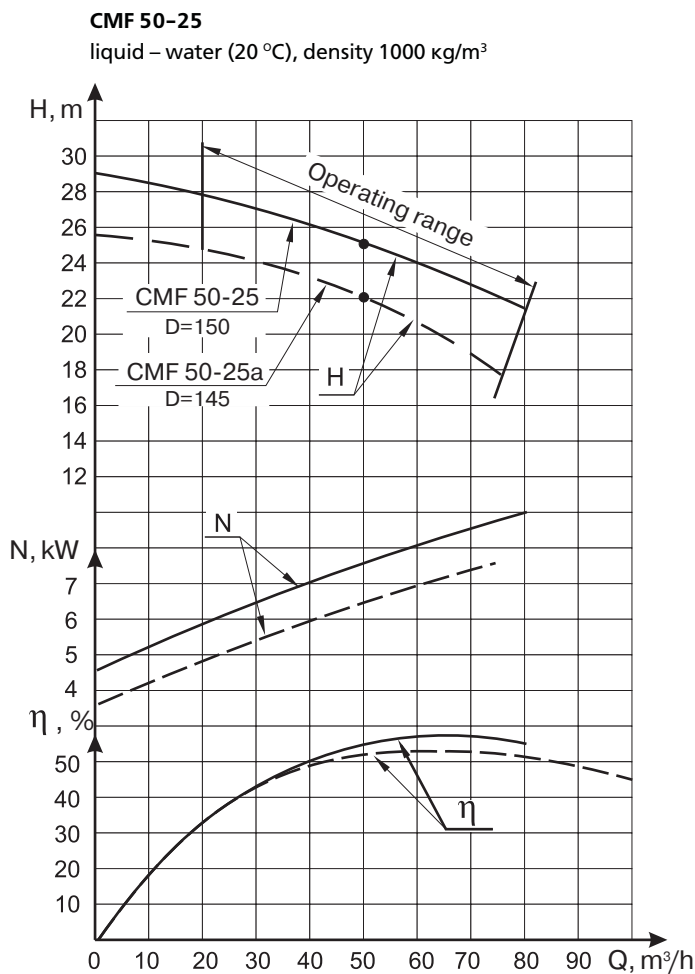

OVERALL DIMENSIONS

CMF 50-25

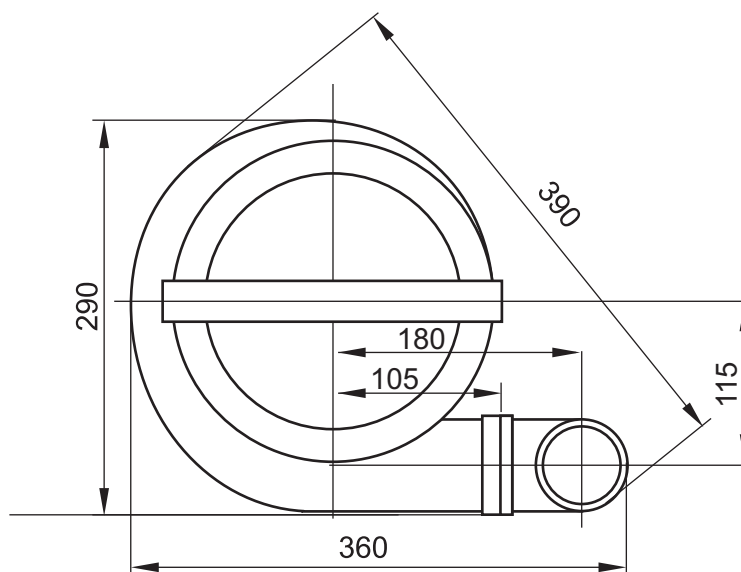
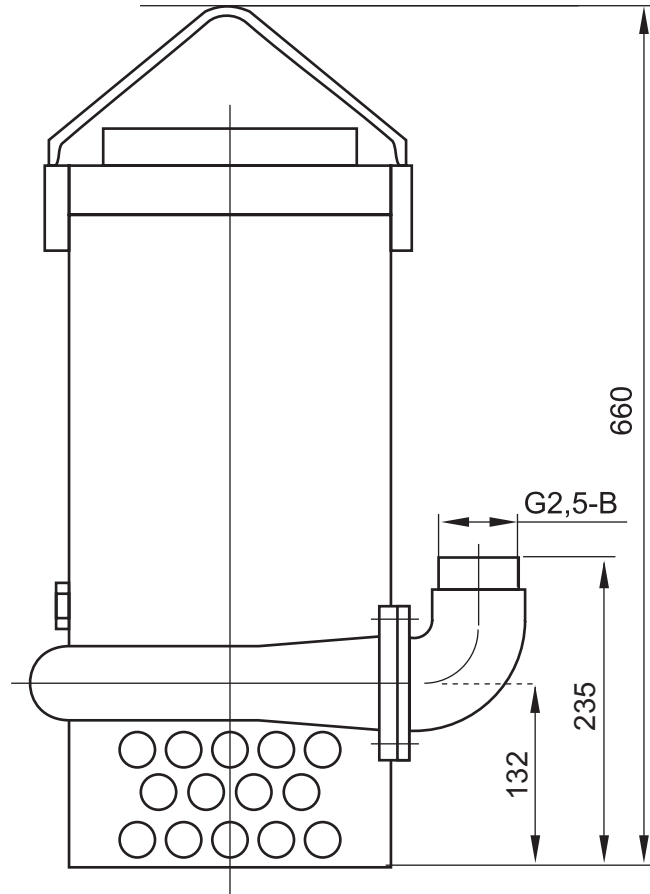

OVERALL DIMENSIONS

CMF 160-80

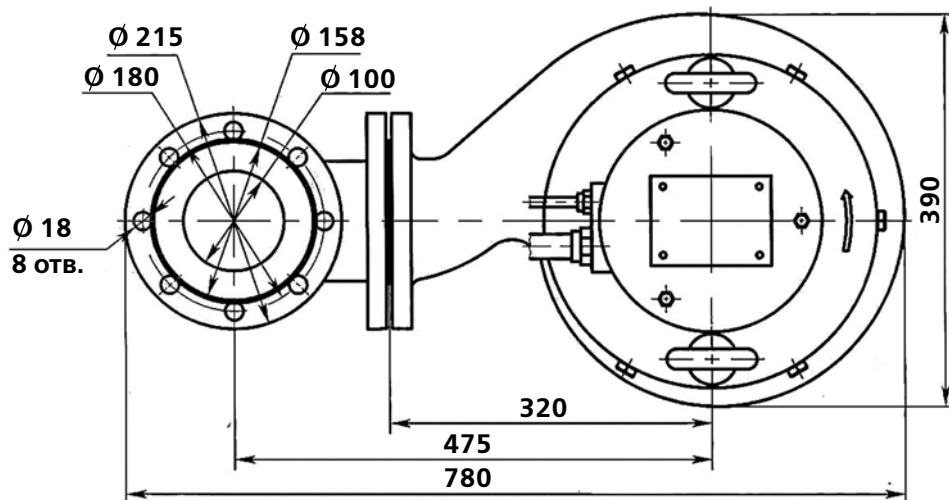
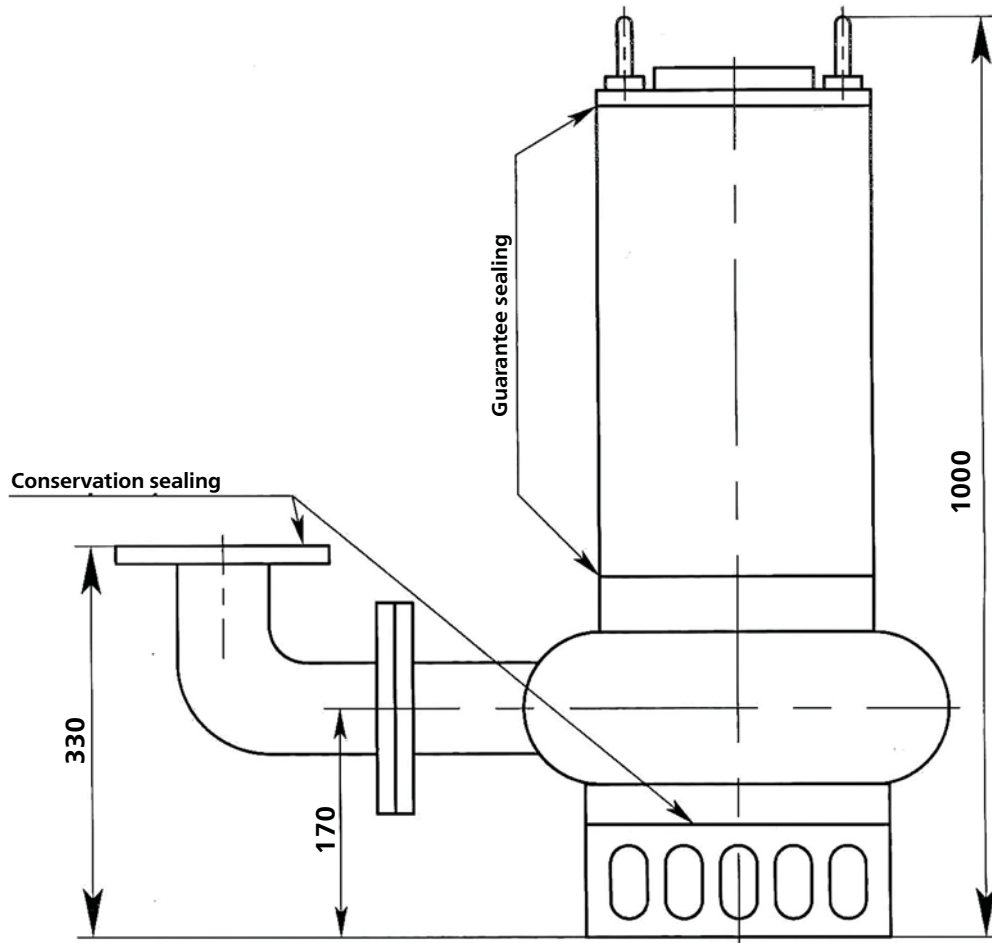

CENTRIFUGAL SUBMERSIBLE ELECTRIC PUMPS OF GNOM TYPE

APPLICATION

Electric pump of **Gnom** type is intended for pumping of contaminated waters with the temperature up to 35 °C (Version **Tr** — up to 60 °C), density up to 1100 kg/m³, with the solid mechanical impurities (sand, cement, clay) content up to 10% by weight, and the maximum size of the particles up to 5 mm.

Advantages

- easily removable filter;
- high reliability and long service life;
- high quality of materials;
- simplicity of maintenance and operation;
- high efficiency;
- operation in all head characteristic range;
- wear resistive impeller provides stable parameters.

Use

The pumps are used for pumping of gravel-clay ground and flood waters from basements, ditches, trenches, etc., in industrial and civil construction in operation of hydraulic facilities, subways and wells, and also, in agriculture for irrigation and drainage.

Design

The electric pump is manufactured as a single-block device. The drive is leak-proof asynchronous electric motor. The pump section is separated from the electric motor with a system of seals with an oil chamber.



Installation

The pump operating position is vertical; it must be fully covered with water for reliable electric motor cooling. The electric pump must be immersed in water using a rope in order to eliminate extension strain on the power cable.

The electric pump installation on a site can be permanent, using hard piping, or mobile using flexible piping.

PUMP TYPE KEYS

Example of designation:

Gnom 10-10 Tr, 380V TU 3631-025-05747979-2003

Gnom XX XX Tr 380V

trade mark

nominal capacity, m³/h

nominal head, m

no designation — for water temperature 35 °C (**Tr** — for 60 °C)

nominal voltage

Example of designation:

Gnom 10-10 D, 220V TU 3631-025-05747979-2003

Gnom XX XX D 220V

trade mark

nominal capacity, m³/h

nominal head, m

no designation — without level sensor

D — with level sensor (floating switch)

nominal voltage

TECHNICAL PARAMETERS

electric pump model	capacity, nom.- max., m ³ /h	head nom.- max., m	el. motor power, kW	voltage, V	current, A	outlet diameter, mm	overall dimensions, mm	weight*, kg, max
Gnom 10-6 Gnom 10-6 D	10-14	6-10	0.6	220	3	50	200x360	15
Gnom 6-10 Gnom 6-10 D	6-14	10-12	0.6	220	3	50	200x360	15
Gnom 10-10 Gnom 10-10 D	10-18	10-13	1.1	220	8	50	200x380	16
Gnom 10-10	10-18	10-13	0.75	380	2	50	200x360	15
Gnom 10-10 Tr	10-18	10-13	1.1	380	2	50	200x360	16
Gnom 16-16	16-24	16-20	2.2	220	11	50	235x450	28
Gnom 16-16	16-24	16-20	2.2	380	3.5	50	235x410	24
Gnom 16-16 Tr	16-24	16-20	2.2	380	3.5	50	235x410	24
Gnom 25-20	25-45	20-25	3	380	6.1	80	300x485	31.8
Gnom 25-20 Tr	25-45	20-25	3	380	6.1	80	300x485	31.8
Gnom 40-25	40-68	25-34	5.5	380	11	78	300x600	59
Gnom 40-25 Tr	40-68	25-34	5.5	380	11	78	300x600	59
Gnom 53-10	53-80	10-15	4	380	8.5	100	370x600	63
Gnom 53-10 Tr	53-80	10-15	4	380	8.5	100	370x600	63

* The weight is specified without power cable. The power cable length is 10 meters

PERFORMANCE RANGE

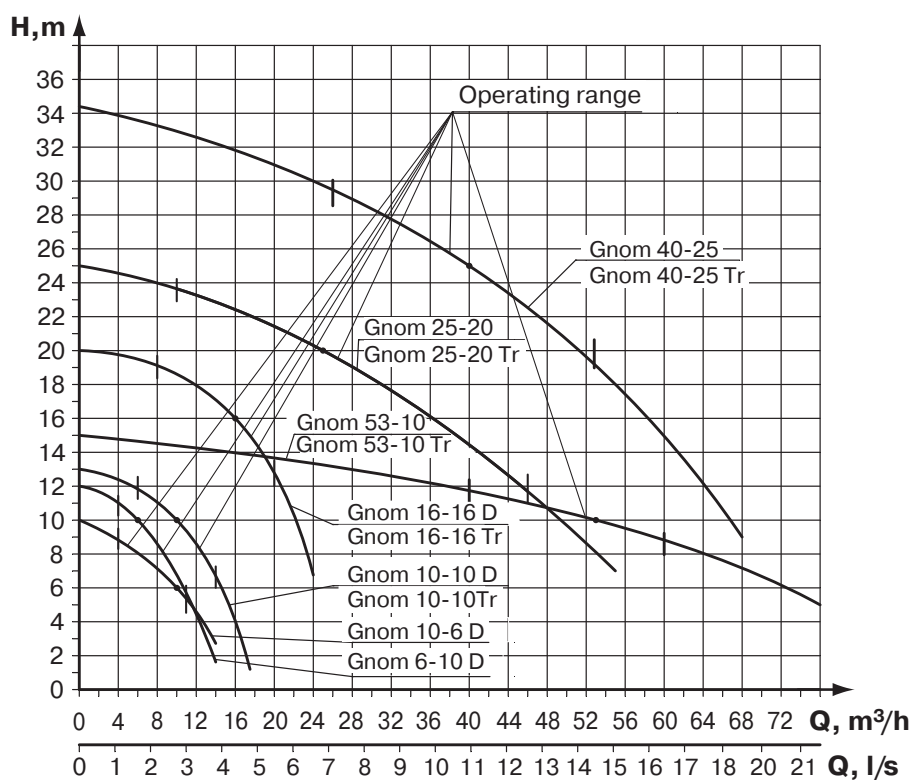

OVERALL DIMENSIONS

Gnom 10-6, Gnom 10-6 D, Gnom 6-10, Gnom 6-10 D, Gnom 10-10, Gnom 10-10 D,
Gnom 16-16, Gnom 16-16 D, Gnom 10-10Tr, Gnom 16-16 Tr

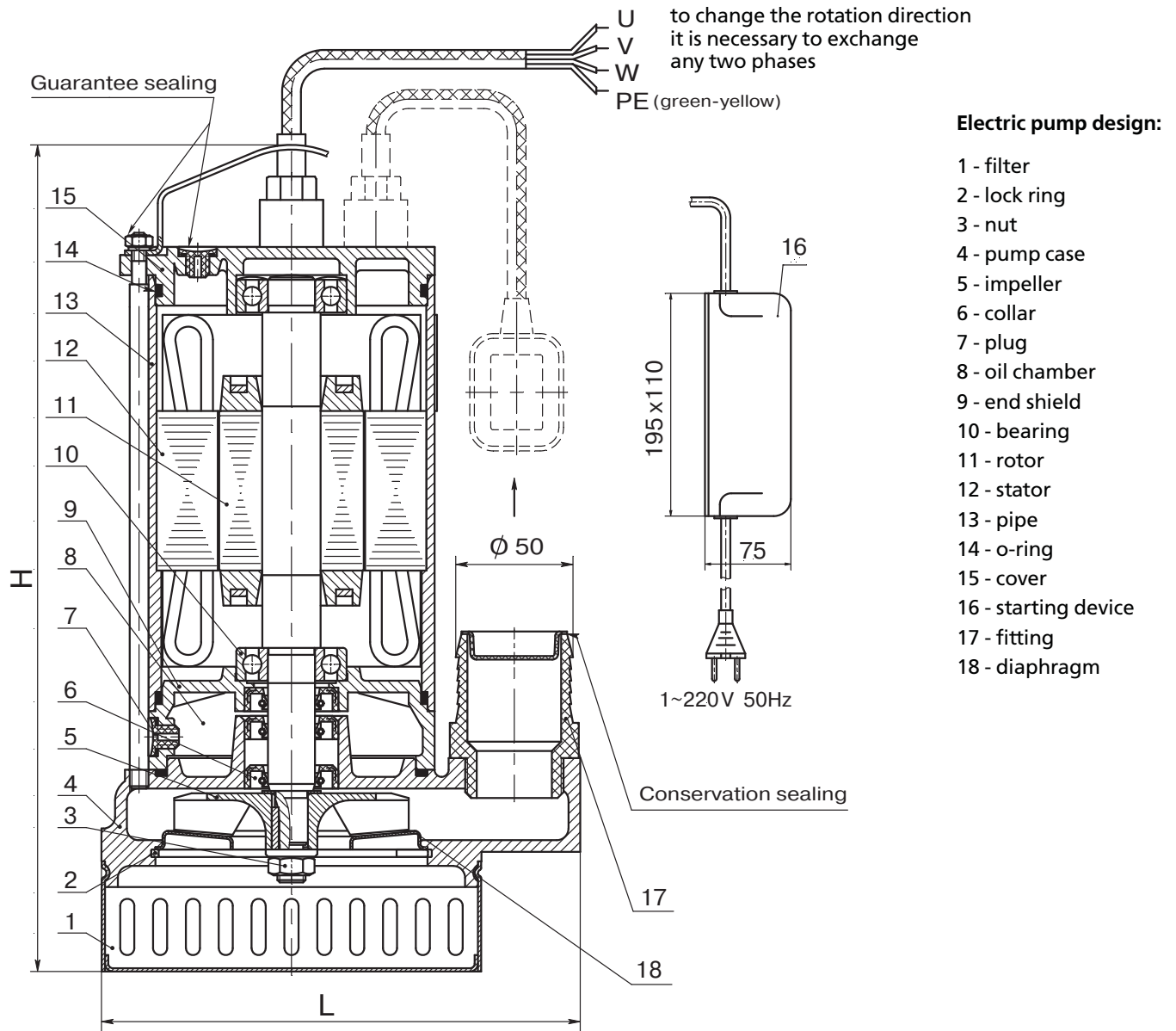

electric pump model	power supply	H, mm	L, mm
Gnom 10-6, Gnom 10-6 D	1~220V	360	210
Gnom 6-10, Gnom 6-10 D		360	210
Gnom 10-10, Gnom 10-10 D		380	210
Gnom 16-16, Gnom 16-16 D		450	245
Gnom 10-10		360	210
Gnom 10-10Tr	3~380V	380	210
Gnom 16-16		420	245
Gnom 16-16Tr		420	245

OVERALL DIMENSIONS

Gnom 25-20, Gnom 25-20 Tr

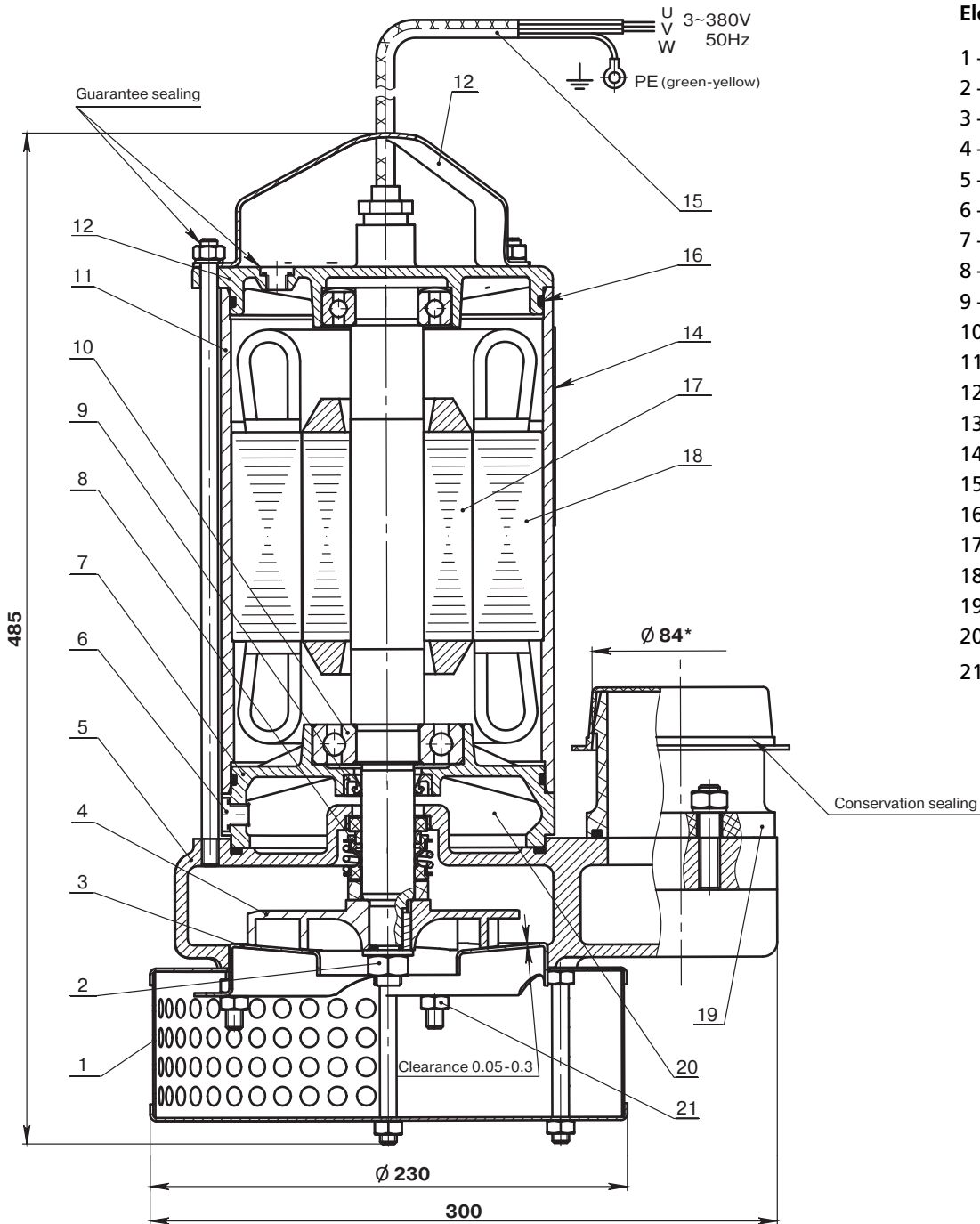

Electric pump design:

- 1 - filter
- 2 - nut
- 3 - diaphragm
- 4 - impeller
- 5 - pump case
- 6 - plug
- 7 - end shield
- 8 - mechanical seal
- 9 - collar
- 10 - bearing
- 11 - pipe
- 12 - cover
- 13 - handle
- 14 - plate
- 15 - power cord
- 16 - rubber ring
- 17 - rotor
- 18 - stator
- 19 - fitting
- 20 - oil chamber
- 21 - nut

OVERALL DIMENSIONS

Gnom 40-25, Gnom 40-25 Tr

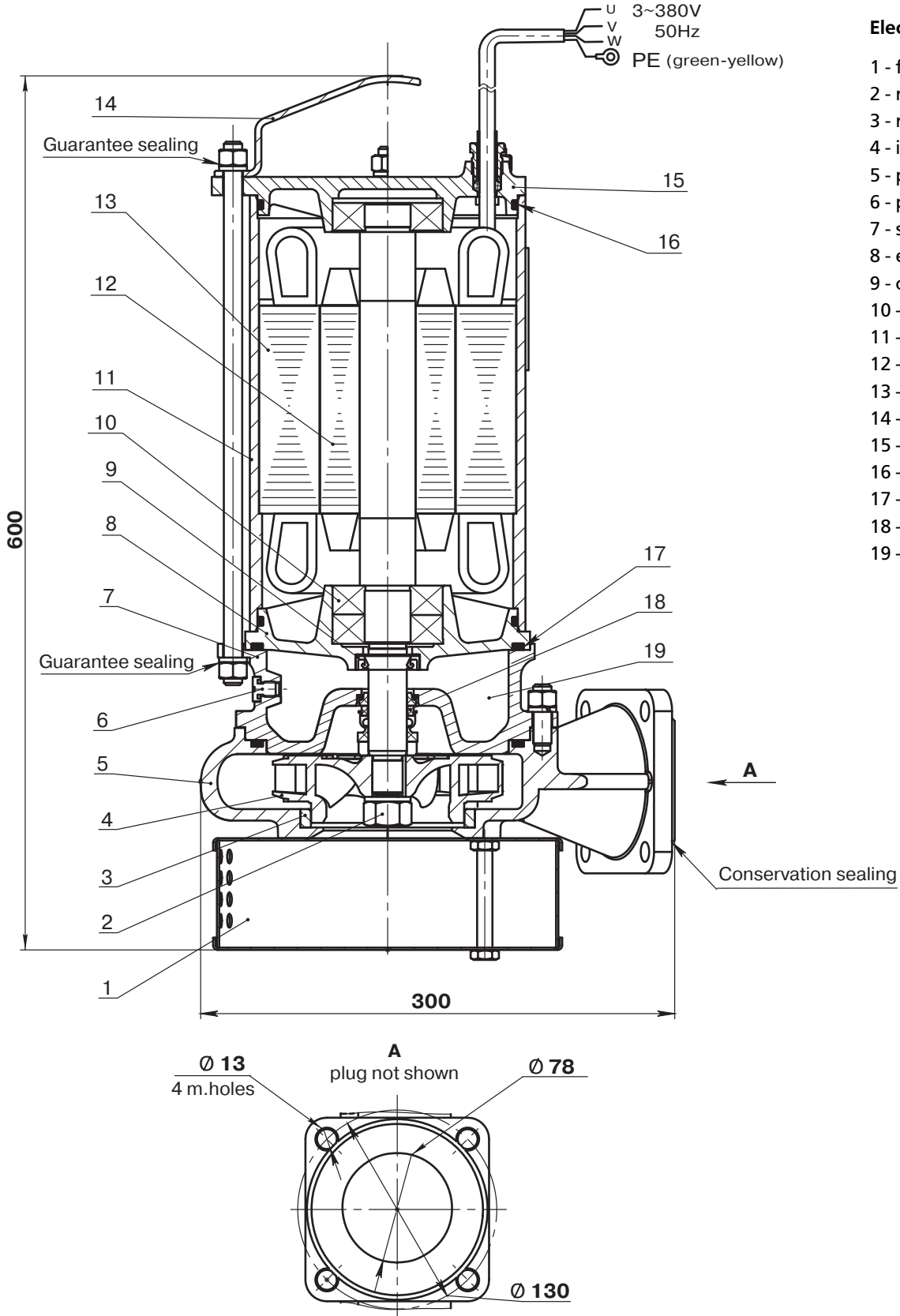

Electric pump design:

- 1 - filter
- 2 - nut
- 3 - ring
- 4 - impeller
- 5 - pump case
- 6 - plug
- 7 - seal case
- 8 - end shield
- 9 - collar
- 10 - bearing
- 11 - motor case
- 12 - rotor
- 13 - stator
- 14 - handle
- 15 - cover
- 16 - o-ring
- 17 - o-ring
- 18 - mechanical seal
- 19 - oil chamber

OVERALL DIMENSIONS

Gnom 53-10, Gnom 53-10 Tr

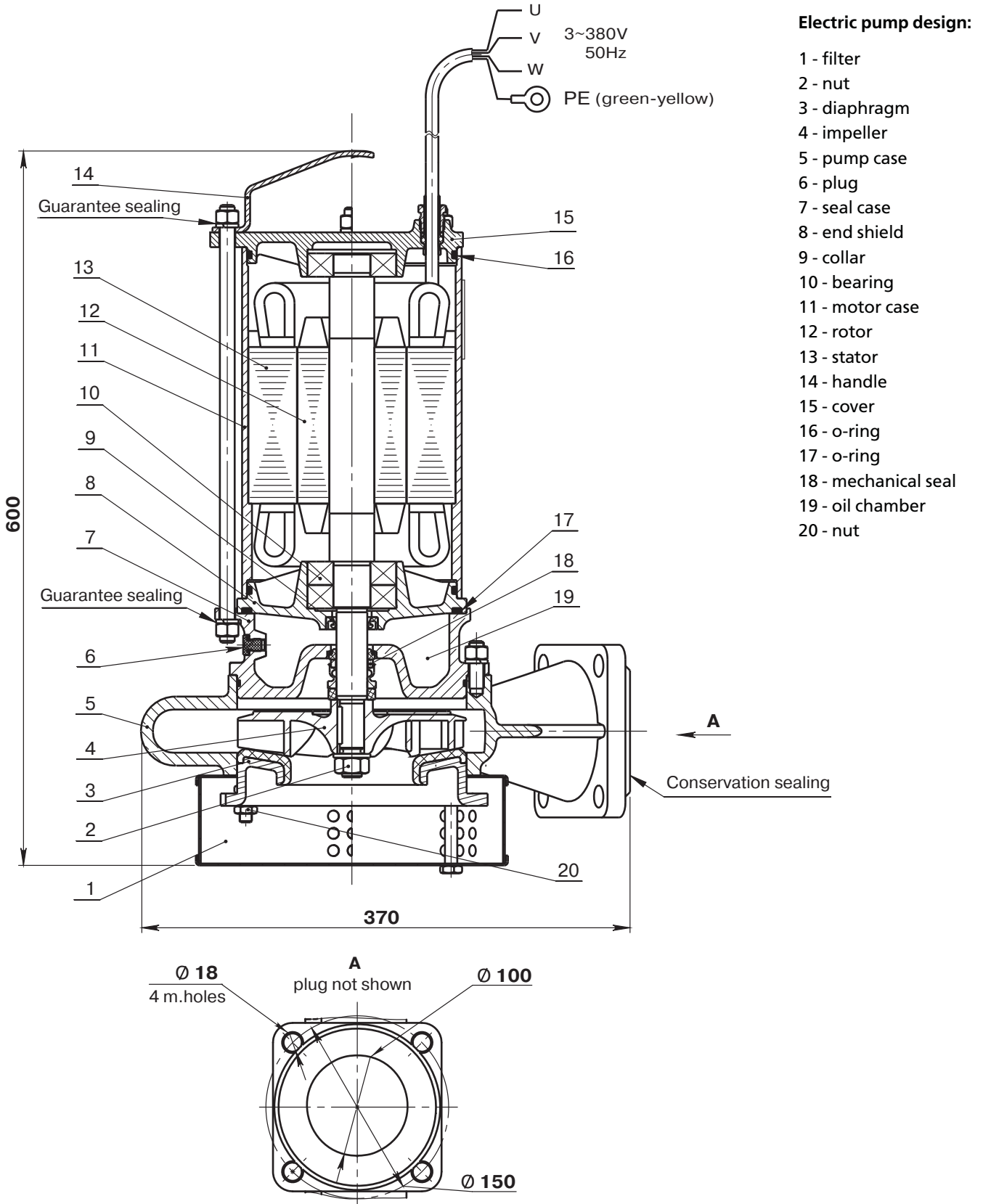

SINGLE-SCREW PUMPS OF N1V TYPE

APPLICATION

Single-screw pumps are intended for pumping of clean and contaminated liquids with the temperature up to 353K (80 °C), including chemically active liquids with the kinematic viscosity up to 4600 cSt (620° relative viscosity). Maximum concentration of suspended particles by weight is not more than 5%, the size of the solid particles is up to 2 mm.

The single-screw pumps can be manufactured for installation:

- on the vessels of sea and river fleet (with acceptance by the Russian Federation Sea Register of Shipping) for pumping of bilge waters containing oil products (marine pumps);
- in process lines of chemical plants for pumping of various chemicals (chemical pumps);
- in coal strip lines and other industries for pumping of mine waters and other contaminated nonaggressive liquids (general industrial pumps).

Upon placement of order the viscosity limits and operating temperature shall be adjusted with the manufacturer.

According to the liquid end design the N1V type pumps can be manufactured of:

- a) structural steel (st.3, steel 20 etc.);;
- b) corrosion resisting steel 12X18N9T;
- c) corrosion resisting steel 10X17N13M3T.



According to the shaft sealing type the N1V type pumps can be manufactured:

- a) with gland packing (default), in case of depression in the pump case it is necessary to supply sealing liquid;
- b) with single face seal;
- c) with double face seal (installation of a double face seal requires supply of sealing liquid to the face seal chamber; the sealing liquid shall be supplied under pressure increasing than the pump pressure by 0,5 kg/cm²).

Single-screw pumps have all advantages of volumetric type pumps: high pressure, little mixing of pump liquid and high suction head, possibility to adjust the delivery by changing the rotating speed. The pump delivery is potentially directly proportional to the rotating speed.

PUMP TYPE KEY

N1V80/5-6.3/5 E - Rp 1 UHL 4.2 TU26-06-1612-90

pump designation under GOST18863-89

pump capacity in a unit, m³/h

pump pressure in a unit, kgf/cm²

pump liquid end material*

E - steel 10X17N13M3T

K - steel 12X18N9T

adjustable capacity designation

drive version

unit climatic version

unit location category

designation of technical conditions

* specified when placing an order

TECHNICAL PARAMETERS

single-screw chemical general industrial units

unit model	pump capacity, m ³ /h	pump pressure, kgf/cm ²	allowable suction head, m	rotating speed, rpm	liquid type, viscosity cSt (°relative viscosity), temperature	motor power, kW	unit weight, kg
N1V1.6/5-0.1/1.6	0.1	1.6	0.5-2.5*	140	spinning solution 4600 (620) 45 °C	1.1	180
N1V6/5-1/2.5-1	1.0	2.5	0-2.5*	360	suspension and paste of titanium dioxide 20 (3) 45 °C	2.2	210
N1V6/5-2.5/1.6	2.5	1.6	0-2.5*	720	paste of titanium dioxide 20 (3) 45 °C	2.2	110
N1V6/10-4/6.3-Rp-1	1.0 - 4.0	6.3	0-2.5*	230-880	mixture of chemicals 10 (1.86) 45 °C	4	225
N1V20/5-10/5-1	10	5.0	0-2.5*	960	suspension and sulfuric acid 2 (1.1) 80 °C	4	185
N1V80/5-6.3/5	6.3	5.0	0.5-2.5*	150	spinning solution 4600 (621) 45 °C	3	324
N1V80/5-6.3/5-Rp-1	1.3 - 6.3	5.0	0.5-2.5*	30-150		4	530
N1V80/5-32/4-1	32	4.0	0-2.5*	730	30% phosphorous acid 2 (1.1) 70 °C	15	395
N1V12/5-10/5-Rp	3-10	5.0	6	485-1450	various chemically active liquids 300 (40.5) 60 °C	5.5	270
N1V12/10-10/10-Rp	3-10	10	6	485-1450		7.5	276
N1V50/5-25/5-Rp	8-25	5.0	6	325-980		11	710
N1V50/10-25/10-Rp	8-25	10	6	325-980		18.5	1147

Inlet pressure is specified in kgf/cm²

unit model	associated equipment			
	im.	electric motor model	speed changer model	reduction gear model
N1V1.6/5-0.1/1.6	2	AIR 80V6	-	1CU160-6.3-21
N1V6/5-1/2.5-1	2	AIM 90L4	-	1CU160-4-21
N1V6/5-2.5/1.6	1	AIR 112MA8	-	-
N1V6/10-4/6.3-Rp-1	3	-	MK50B5	-
N1V20/5-10/5-1	1	AIM 112MV6	-	-
N1V80/5-6.3/5	2	AIR 112MV8	-	1CU160-5-21
N1V80/5-6.3/5-Rp-1	3	-	MK50/2	-
N1V80/5-32/4-1	1	AIM 180M8	-	-
N1V12/5-10/5-Rp	1	AIR112M4	-	-
	3	-	RX77D36DV132S2	-
N1V12/10-10/10-Rp	1	A132S4	-	-
	3	-	RX77D36DV132S2	-
N1V50/5-25/5-Rp	1	VA160M6	-	-
	3	-	RX77D36DV132S2	-
N1V50/10-25/10-Rp	1	VA180M6	-	-
	3	-	RX77D36DV132S2	-

As new types of associated equipment may be used (reduction gears, speed changers, motors), the unit design may be changed, which is not specified in this catalog

PERFORMANCE RANGE

Units N1V with adjustable delivery

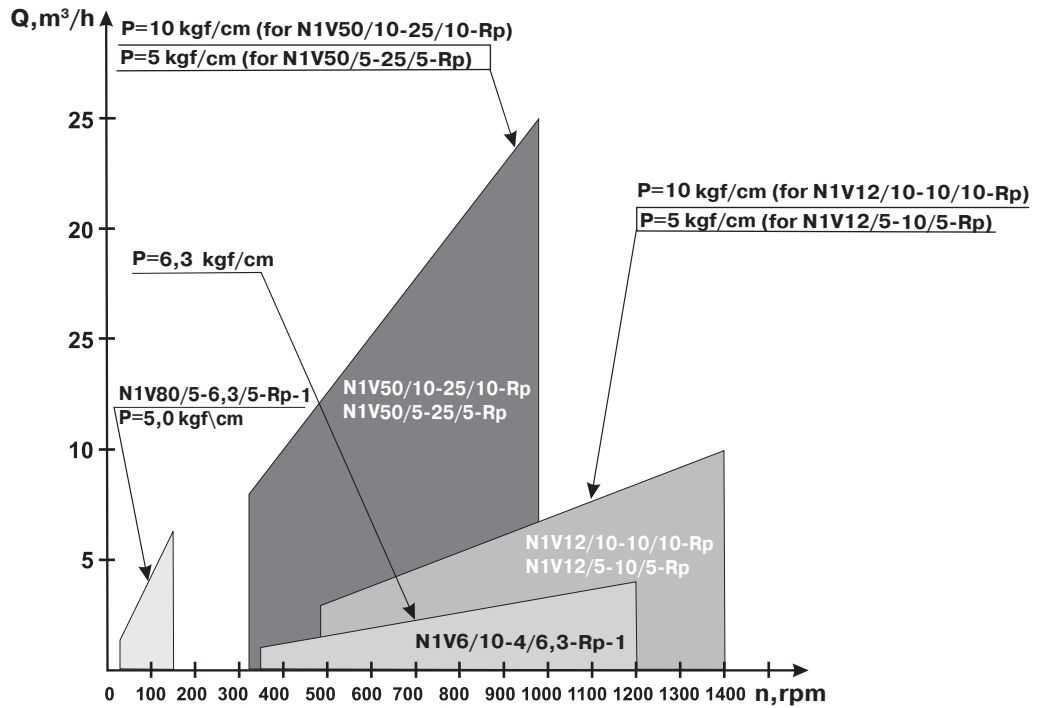

Units N1V with delivery more than 5 m³/h

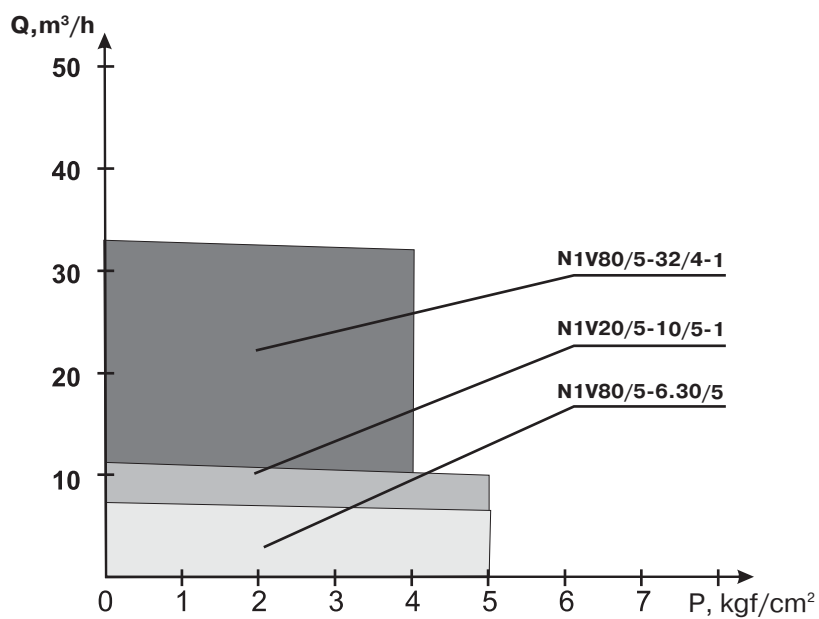

OVERALL DIMENSIONS

Image 1. Unit type N1V

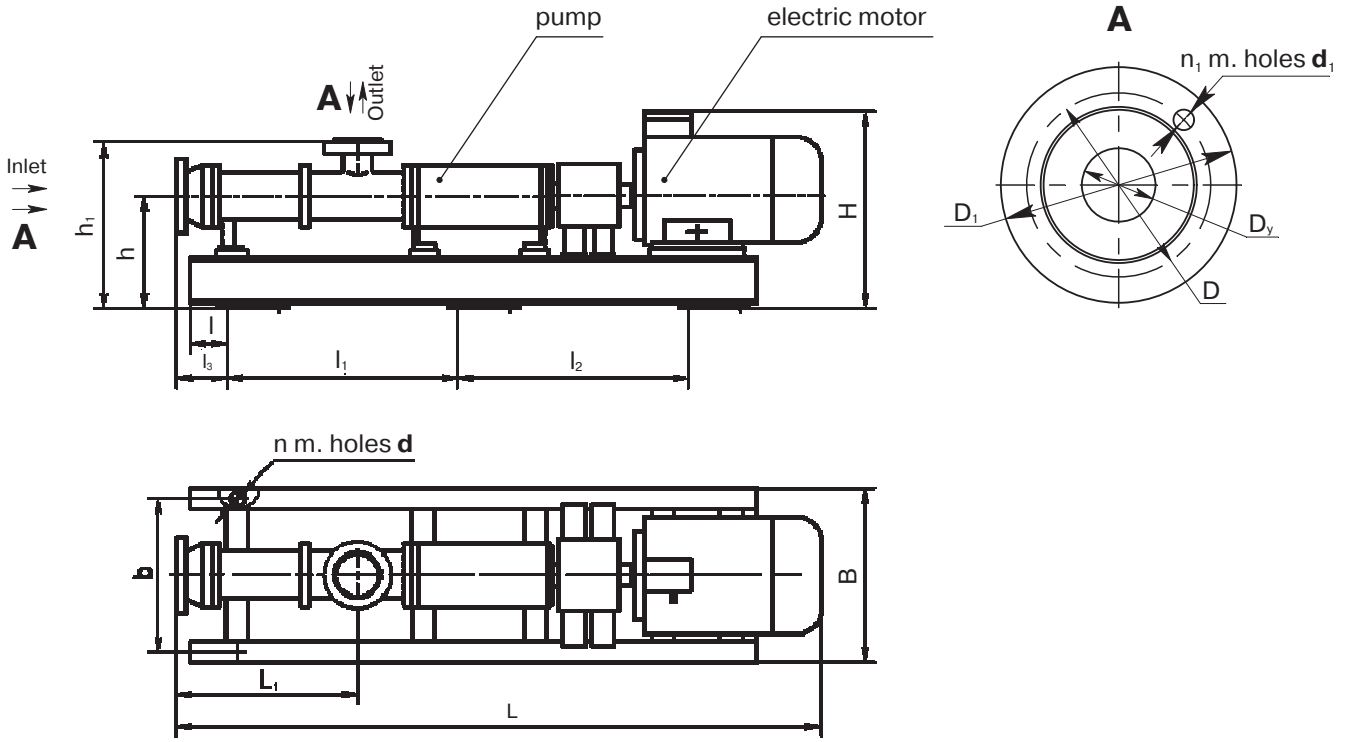
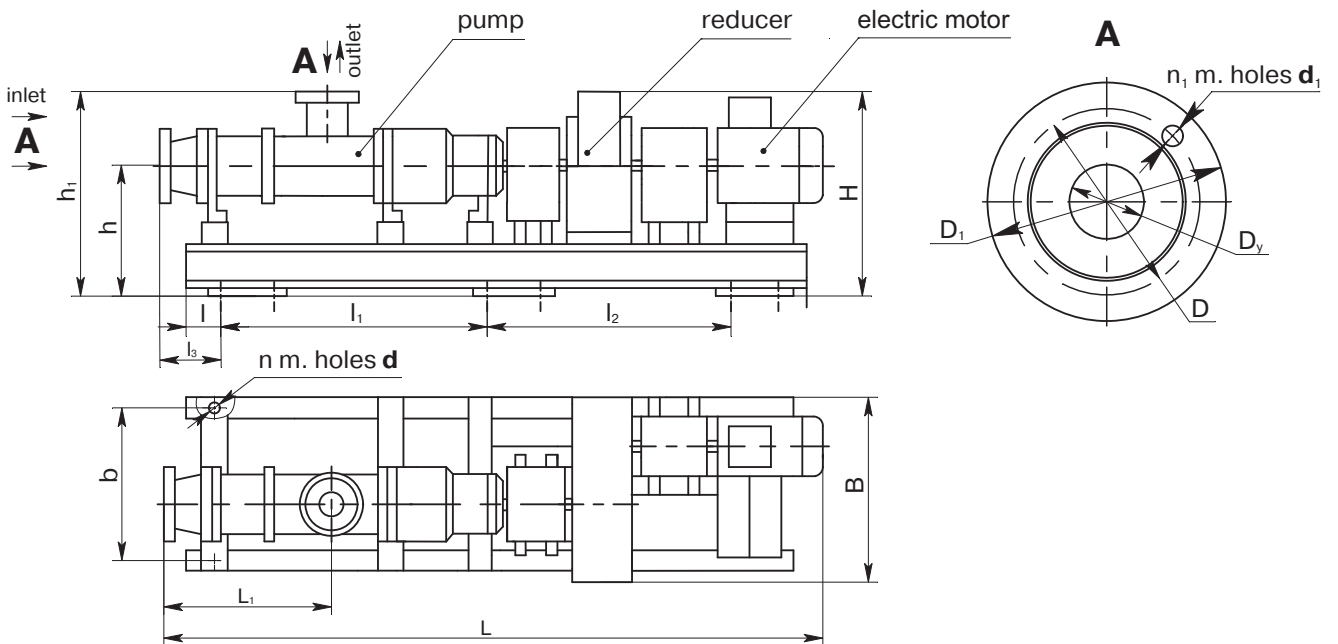
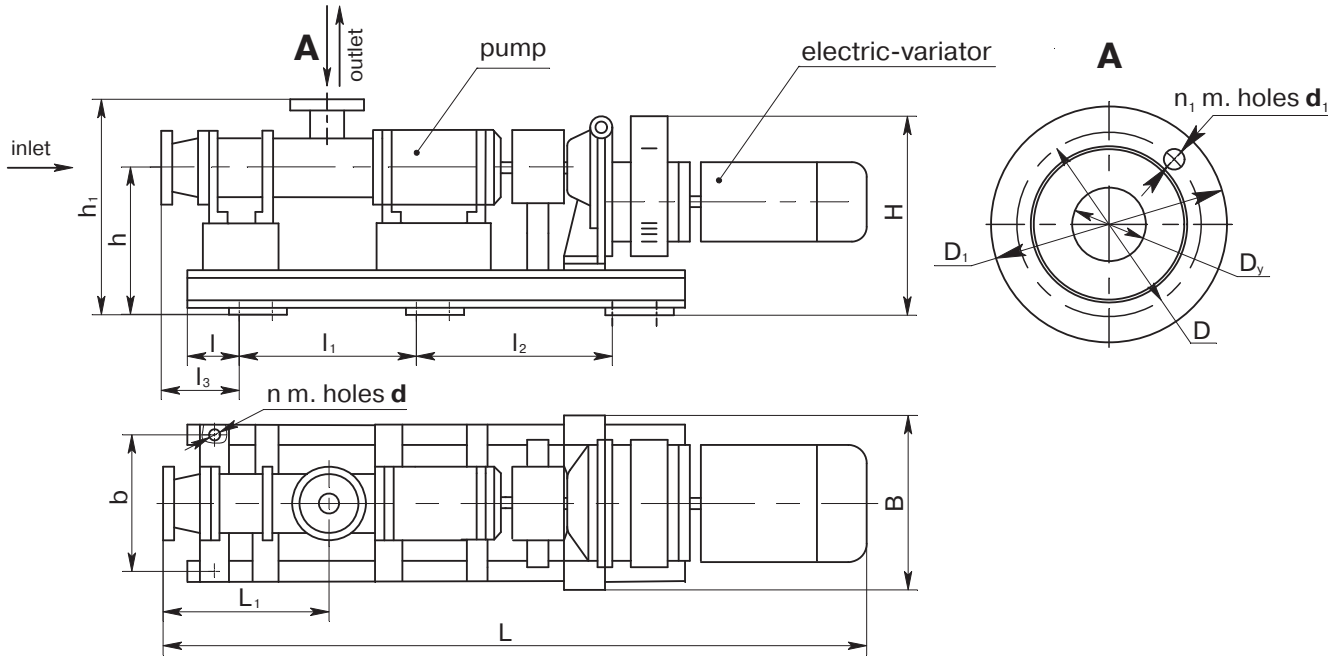

Image 2. Unit type N1V (with reducer)



OVERALL DIMENSIONS

Image 3. Unit type N1V (with variator)



unit model	im.	L	B	H	l	l ₁	l ₂	l ₃	L ₁	b	h	h ₁	d	n	D _y	D	D ₁	d ₁	n ₁
N1V1.6/5-0.1/1.6	2	1478	470	455	30	550	550	95	285	190	280	350	18	6	32	83	115	14	6
N1V6/5-1/2.5-1	2	1706	475	512	45	700	700	112	342	190	280	384	18	6	40	93	125	14	6
N1V6/5-2.5/1.6	1	1285	230	385	45	860	-	112	342	190	212	316	18	4	40	93	125	14	6
N1V6/10-4/6.3-Rp-1	3	1670	280	445	80	400	400	160	490	240	270	370	18	6	40	93	125	14	6
N1V20/5-10/5-1	1	1630	310	530	65	1010	-	172	440	270	225	345	18	4	80	160	195	18	4
N1V80/5-6.3/5	2	2200	495	535	35	880	880	177	685	410	356	510	18	6	100	180	215	18	8
N1V80/5-6.3/5-Rp-1	3	2405	320	565	50	745	745	257	685	250	310	455	18	6	100	180	215	18	8
N1V80/5-32/4-1	1	2300	410	715	50	800	800	192	685	300	360	505	18	6	100	180	215	18	8
N1V12/5-10/5-Rp	1	1760	312	540	150	700	700	240	365	270	235	345	18	6	50	125	160	14	4
N1V12/5-10/5-Rp*	3	1310	372	405	70	500	500	65	365	330	240	405	18	6	50	125	160	14	4
N1V12/10-10/10-Rp	1	2035	380	585	150	700	700	240	540	334	235	345	18	6	50	125	160	14	4
N1V12/10-10/10-Rp*	3	1549	412	436	70	400	400	65	540	370	252	436	18	6	50	125	160	14	4
N1V50/5-25/5-Rp	1	2200	500	945	175	720	720	225	536	396	418	565	18	6	80	160	195	18	8
N1V50/5-25/5-Rp*	3	1900	355	675	175	650	650	295	535	254	315	455	18	6	80	160	195	18	8
N1V50/10-25/10-Rp	1	2465	400	1096	175	800	800	295	795	250	323	463	18	6	80	160	195	18	8
N1V50/10-25/10-Rp*	3	2210	370	665	175	800	800	295	795	280	335	475	18	6	80	160	195	18	8

* - units with variators

WATER-CIRCUIT VACUUM PUMPS OF VVN TYPE

APPLICATION

Water-circuit vacuum pumps are intended for pumping of air or nonaggressive gases and vapor-gas mixtures prepurified from the main volume of condensed moisture and can operate with air, water or nonaggressive gases, vapors and liquids.

The pumps do not require purification of in-going gas and also, allow for ingress of liquids into the device together with the induced air. The pumps are intended for chemical, food, paper-pulp, oil, gas and other industries. Electric pump **VVN1-1.5** can also be used in agricultural farms (for milking units).

Electric pump **2VVN1-0.8** can be use in explosion and fire hazardous premises if equipped with explosion-proof motor AIM 80V2 U2.5.

Electric pumps **VVN1-1.5** and **2VVN1-0.8** are manufactured in closed-coupled version.



PERFORMANCE RANGE

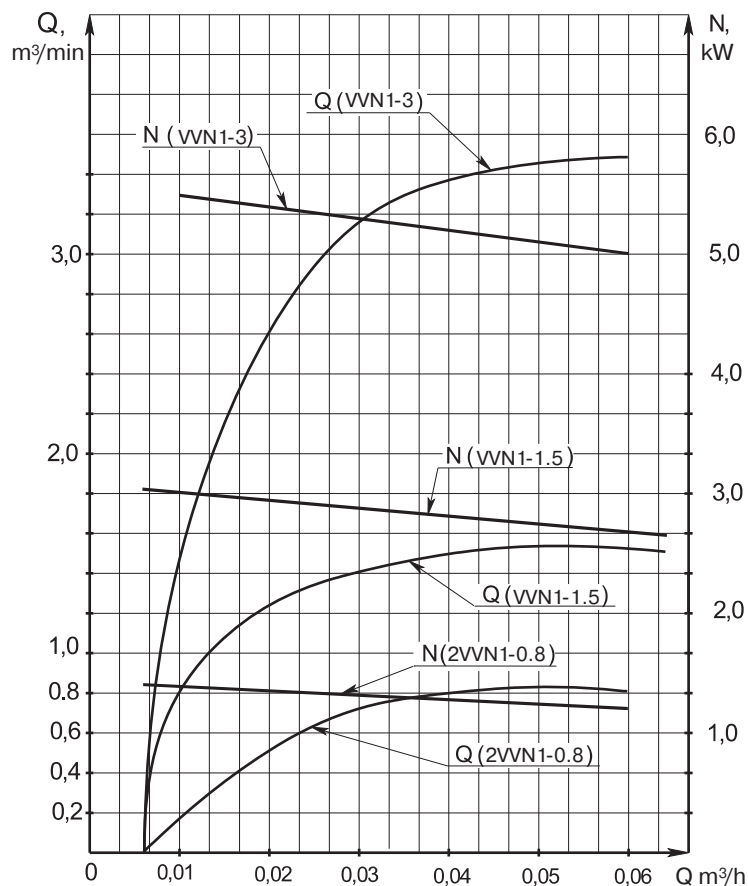

PUMP TYPE KEY

Example of designation:

2 VVN1-0,8 - UHL 4

2 - upgrade serial number

vacuum water-circuit electric pump
with nominal pressure 0,04 MPa

capacity m³/min

climatic version

location category

X VVN - XX UHL X

TECHNICAL PARAMETERS				
parameter	value for model			
	electric pumps		pump (units)	
	2VVN1-0.8	VVN1-1.5	VVN1-3	VVN1-0.75
nominal capacity, normalized to initial conditions at the nominal suction pressure 0,04 MPa (0,4 kgf/cm ²)*, m ³ /s (m ³ /min)	0.014 (0.8) ±10%	0.026 (1.57) +20% -5%	0.056 (3.33) ±10%	0.0125 (0.75) ±10%
decrease of nominal capacity at the suction pressure 0,02 MPa (0,2kgf/cm ²), %, max	40	-	20	40
power consumed at the nominal capacity*, kW, maximum	1.3 ±0.13	3.0 ±0.30	6.15 ±10%	
specific power, kW/m ³ min., max	1.6	4.4		2.0
water consumption, dm ³ /s (m ³ /h), max	0.056 (0.2)	0.083 (0.3)	0.116 (0.42)	0.056 (0.2)
rotating speed, s ⁻¹ (rpm)	48.3 ±0.833 (2900±50)	25 ±0.833 (1500±50)		24 ±0.833 (1450±50)
power supply	current	alternating		
	voltage, V	380, 220/380		
	frequency, Hz	50		
motor power, kW	2.2	5.5	7.5	2.2
electric pump weight, kg, max	42.5	110		
weight of pump, kg, max	-	-	110	38
weight of unit, kg, max	-	-	210	90
leakage through the gland seal, cm ³ /h, max	-	100	100	100

The technical parameters shall be provided at the pumped gas temperature not more than 293K (20 °C), power water temperature not more than 288K (15 °C)

OVERALL DIMENSIONS

Pump VVN1-0.75

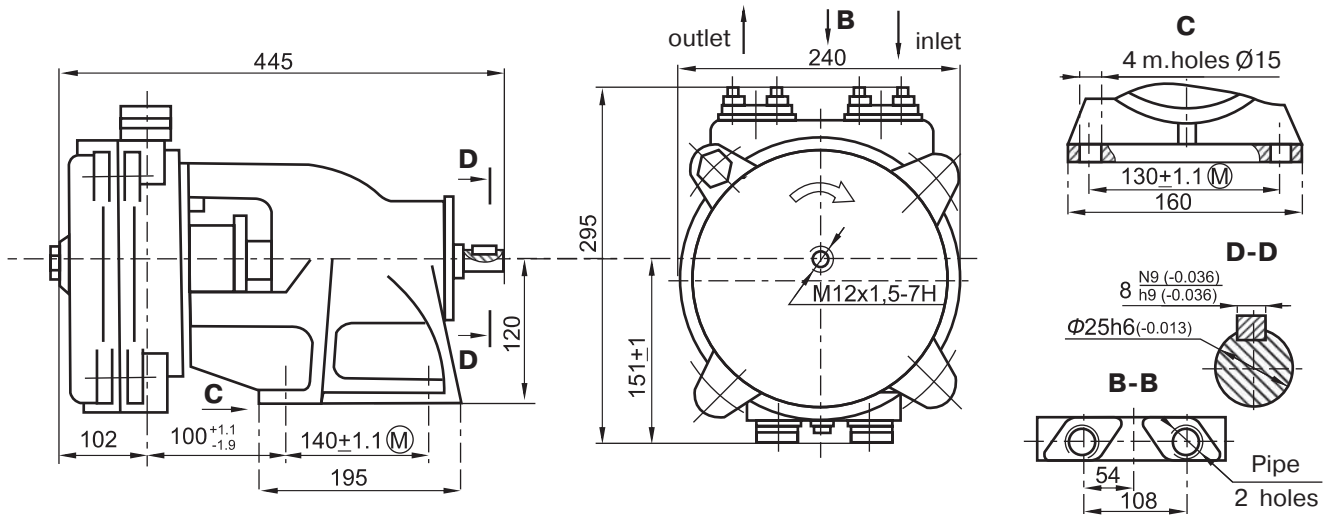

Unit VVN1-0.75

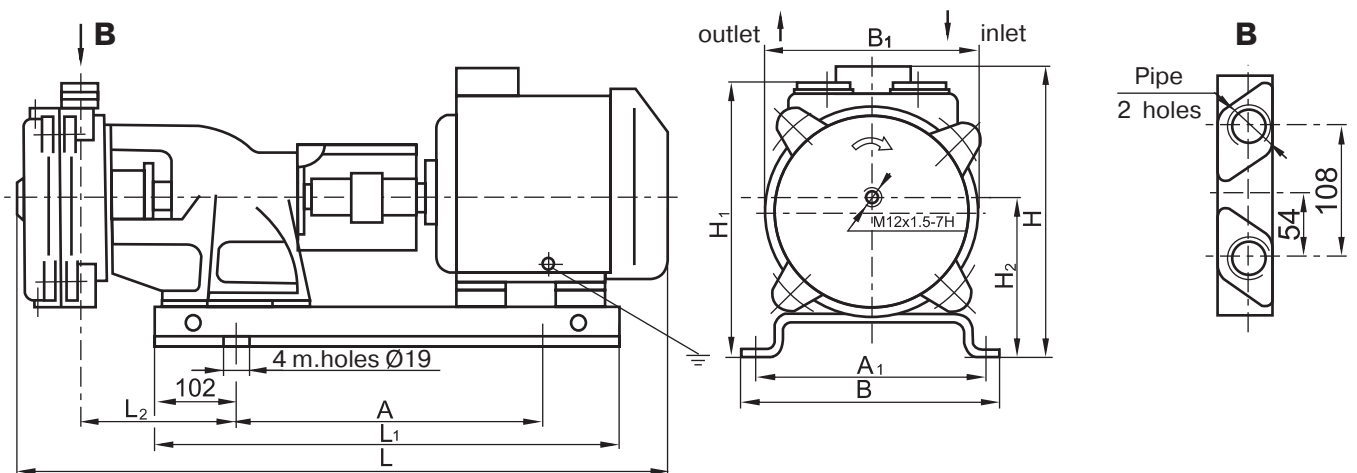

electric motor model	power, kW	dimensions in mm										weight, kg
		L	L ₁	L ₂	A	A ₁	B	B ₁	H	H ₁	H ₂	
AIR 90 L4	2.2	820	575	170	369±1.1 (M)	285±1.1 (M)	332	240	315	312	180	72
A90L4	2.2	870	575	170	369±1.1 (M)	285±1.1 (M)	332	240	307	312	180	80

OVERALL DIMENSIONS

Electric pump 2VVN1-0.8

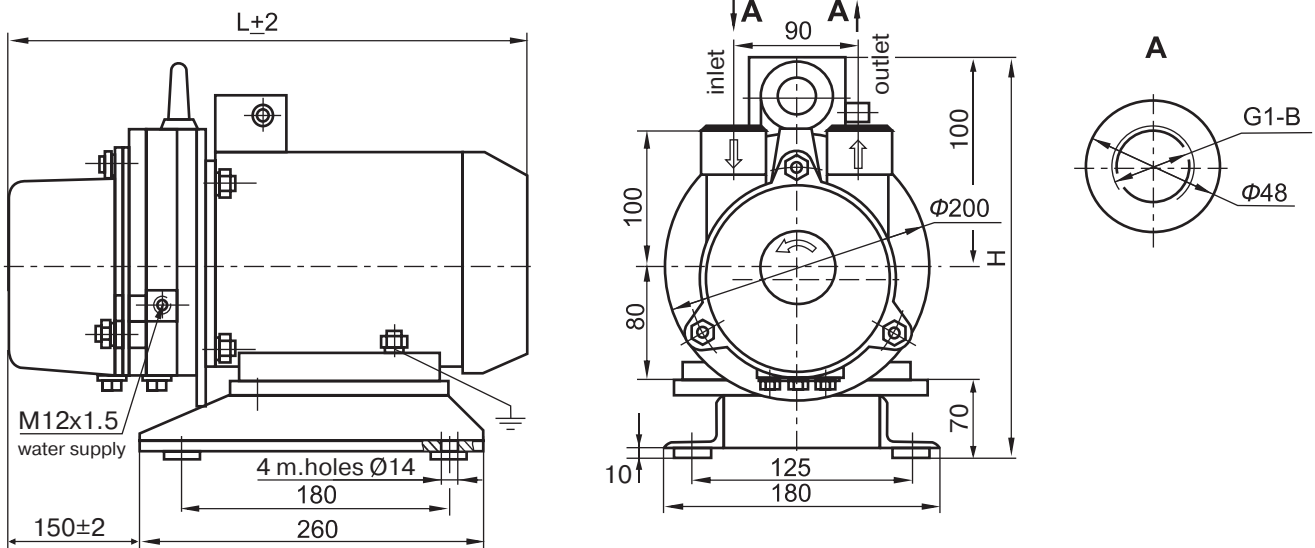

electric motor model	L, MM	H, MM	weight, kg
AIM 80V2 U2.5	456	315	42.5
AIR 80V2 U2	416	266	30.5
5A 80MV2 U2	416	266	30.5

Electric pump VVN1-1.5

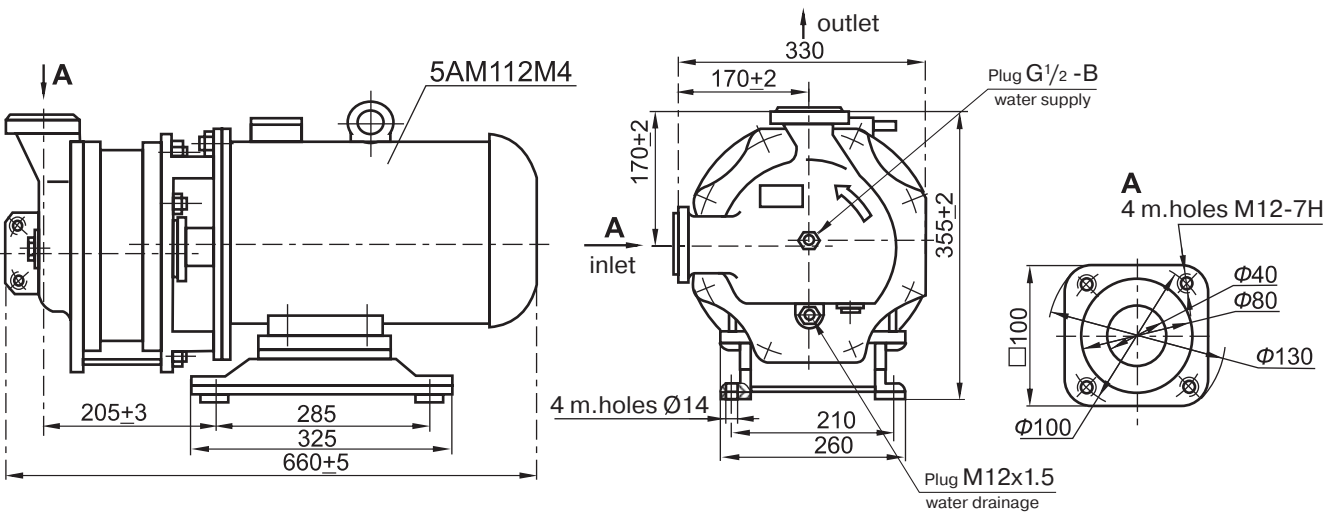

OVERALL DIMENSIONS

Pump VVN1-3

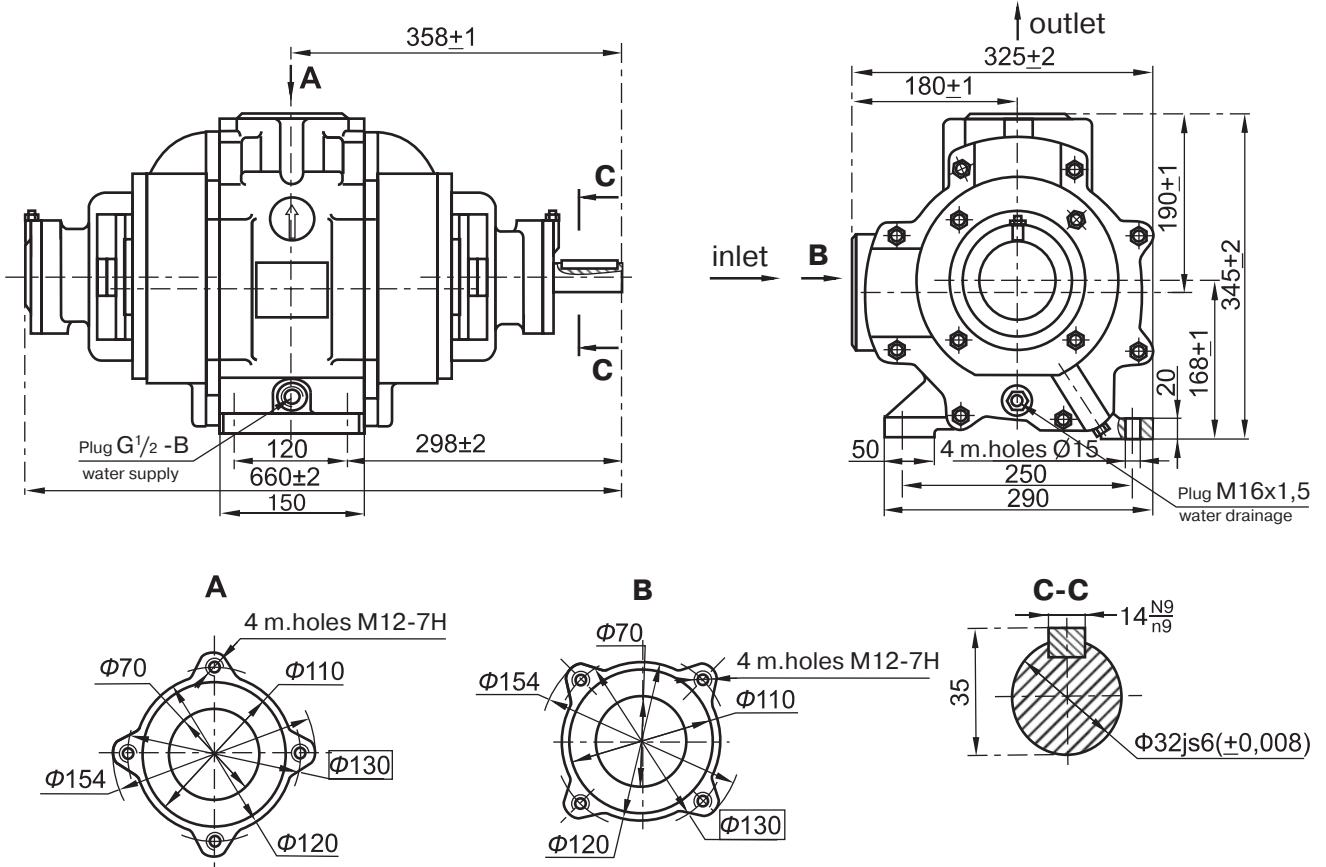

Unit VVN1-3

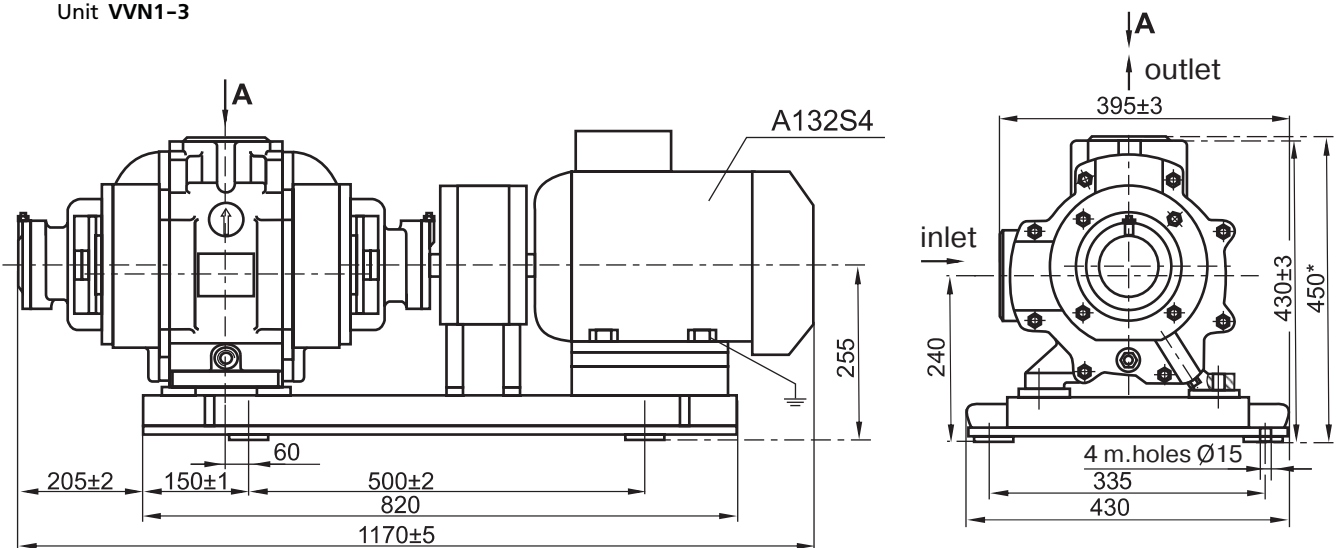

AUTOMATED PUMPING WATER BOOSTER SYSTEMS – AUPD

APPLICATION

Automated pumping water booster systems **AUPD 2 MHN KR**, **AUPD 3 MHN KR**, **AUPD 2 MHN KCHR** are intended for automated boosting and maintenance of necessary pressure in water supply systems.

The pumped media is water and other liquids similar to it in their density, viscosity, chemical activity, not containing mineral oils, abrasive and fibrous impurities.

Design features

AUPD 2 MHN KR / AUPD 3 MHN KR

The pump units control is cascade, providing maintenance of pressure in water supply systems within the range from P_{\min} to P_{\max} by means of the pumps switching on/off.

Pump units **AUPD 2 MHN KR** and **AUPD 3 MHN KR** consist of 2 or 3 pumps of **MHN** series, respectively, mounted on one frame and interconnected by suction and discharge manifolds, control box, stop valves, pneumatic hydraulic accumulator with the capacity of 8l, pressure sensor and signaling pressure indicator (ECM) mounted on the discharge manifold.

Design features

AUPD 2 MHN KCHR

The pump units control is cascade-frequency, providing smooth (stepless) maintenance of constant pressure P_{nom} within the operating range of delivery.

The pump units consist of 2 pumps of **MHN** series mounted on one frame and interconnected by suction and discharge manifolds, control box, stop valves, pneumatic hydraulic accumulator with the capacity of 8l, pressure transformer and manometer mounted on the discharge manifold.

Auxiliary equipment

The pump units may also be equipped with two rubber coupling vibration dampeners for connection to the water supply system. The total mounting length of the dampeners is 200...220 mm.

Dry operation protection

Depending on the type of connection to the water supply system, the units shall be equipped with the following devices:



- relay for protection against dry operation on the suction manifold, in case of direct connection (all units);
- floating switch (all units);
- electrode-sensor for control of level in the tank (units **AUPD 2 MHN KR** and **AUPD 3 MHN KR**) in case a receiving tank is connected to the unit.

Pneumatic hydraulic accumulator

The pump unit shall be equipped by the customer with an auxiliary pneumatic hydraulic accumulator of a sufficient capacity connected to the pressure line.*

The necessity of the pump unit supply complete with the hydraulic accumulator of a particular capacity and a set of flexible pipe fittings for connection to the discharge manifold shall be specified upon placement of order.

* See connection schemes (page 169). The minimum required capacity of hydraulic accumulator is stipulated in the technical specifications

TECHNICAL PARAMETERS		
parameter	AUPD 2 MHN KR/AUPD 3MHN KR	AUPD 2 MHN KCHR
	pump unit	
number of pumps, pcs.	2-3	2
control	cascade	cascade-frequency
power supply	3~380 V, 50 Hz	
maximum operating pressure, MPa	0.6	
maximum pressure in the pump case, MPa	0.8	
minimum back pressure when operating with relay for protection against dry operation, MPa	0.05	
hydraulic accumulator volume, l	8	
protection class	IP54	
temperature of operating medium, °C	+5 ... +40	
environment temperature, °C	+5 ... +35	

function	control box	
short circuit protection	+	+
current overload protection	+	+
phase failure and distortion protection	-	+
motor capacity balancing	+	+
electric pump reservation	+	+
front panel indication: Network, Operation, Emergency	+	+
mode selection: Manual, Automatic	+	-
dispatching: Emergency of each pump (dry contacts)	+	+
remote monitoring: connection RS-485 MODBUS*	+	+

* Not included in the standard set for AUPD 2 MHN KCHR – to be specified separately upon placement of order

parameter	asynchronous electric pump
insulation class	F
synchronous rotating speed, rpm	3000

MATERIALS USED IN AUPD 2 MHN KR, AUPD 3 MHN KR, AUPD 2 MHN KCHR

pump	material
pump and cascade case, pump cover	chrome-nickel steel 1.4301 EN 10088 (AISI 304)
impeller ring seal	PTFE (teflon)
impeller	chrome-nickel steel 1.4301 EN 10088 (AISI 304)
pump shaft	chrome-nickel steel 1.4305 EN 10088 (AISI 303)
mechanical seal with a slot under ISO 3069	alumina ceramic, charcoal, EPDM

pump unit components	material
manifold	chrome-nickel steel 08X18N GOST 9941-81 (AISI 304)
stop valves	brass
frame elements	St 3

TECHNICAL PARAMETERS AUPD 2 MHN KR / AUPD 3 MHN KR

unit model	number of pumps	power, kW (1+1)	capacity (Q, m ³ /h)		pressure setting*		hydraulic accumulator min. capacity, l
			one reserve pump	all operating pumps	P _{min} , MPa	P _{max} , MPa	
AUPD 2 MHN 203E KR	2	0.45+0.45	1-4.5	1-9	0.17	0.27	80
AUPD 2 MHN 204E KR		0.55+0.55			0.27	0.37	
AUPD 2 MHN 205E KR		0.75+0.75			0.35	0.49	
AUPD 3 MHN 203E KR	3	0.45+0.45+0.45	1-9	1-13.5	0.17	0.27	
AUPD 3 MHN 204E KR		0.55+0.55+0.55			0.27	0.37	
AUPD 3 MHN 205E KR		0.75+0.75+0.75			0.35	0.49	
AUPD 2 MHN 403E KR	2	0.55+0.55	2.25-8	2.25-16	0.19	0.29	100
AUPD 2 MHN 404E KR		0.75+0.75			0.29	0.39	
AUPD 2 MHN 405E KR		1.1+1.1			0.35	0.49	
AUPD 3 MHN 403E KR	3	0.55+0.55+0.55	2.25-16	2.25-24	0.19	0.29	
AUPD 3 MHN 404E KR		0.75+0.75+0.75			0.29	0.39	
AUPD 3 MHN 405E KR		1.1+1.1+1.1			0.35	0.49	
AUPD 2 MHN 803 KR	2	1.1+1.1	5-13	5-26	0.19	0.29	200
AUPD 2 MHN 804 KR		1.5+1.5			0.3	0.4	
AUPD 2 MHN 805 KR		1.8+1.8			0.35	0.5	
AUPD 3 MHN 803 KR	3	1.1+1.1+1.1	5-26	5-39	0.19	0.29	
AUPD 3 MHN 804 KR		1.5+1.5+1.5			0.3	0.4	
AUPD 3 MHN 805 KR		1.8+1.8+1.8			0.35	0.5	

TECHNICAL PARAMETERS AUPD 2 MHN KCHR

unit model	power, kW (1+1)	regular capacity (Q, m ³ /h)		max. capacity (Q, m ³ /h)		pressure setting* P _{nom} , MPa	hydraulic accumulator min. capacity, l
		main + reserve	main + main	main + reserve	main + main		
AUPD 2 MHN 203E KCHR	0.45 +0.45	0.5 - 3.5	0.5 - 7	4.5	9	0.18	24
AUPD 2 MHN 204E KCHR	0.55 +0.55					0.26	
AUPD 2 MHN 205E KCHR	0.75 +0.75					0.33	
AUPD 2 MHN 403E KCHR	0.55 +0.55	1 - 6	1 -12	8	16	0.19	35
AUPD 2 MHN 404E KCHR	0.75 +0.75					0.25	
AUPD 2 MHN 405E KCHR	1.1 +1.1					0.33	
AUPD 2 MHN 803 KCHR	1.1 +1.1	2.5 - 10	2.5 - 20	13	26	0.22	50
AUPD 2 MHN 804 KCHR	1.5 +1.5					0.30	
AUPD 2 MHN 805 KCHR	1.8 +1.8					0.37	

* Before beginning of operation it is necessary to adjust the pressure setting considering the available back pressure

ATTENTION!

It is prohibited to operate the pump units without dry operation protection and pneumatic hydraulic accumulator of a sufficient capacity.

FUNCTIONAL SCHEME. CONNECTION OF AUPD 2 MHN KR/AUPD 3 MHN KR

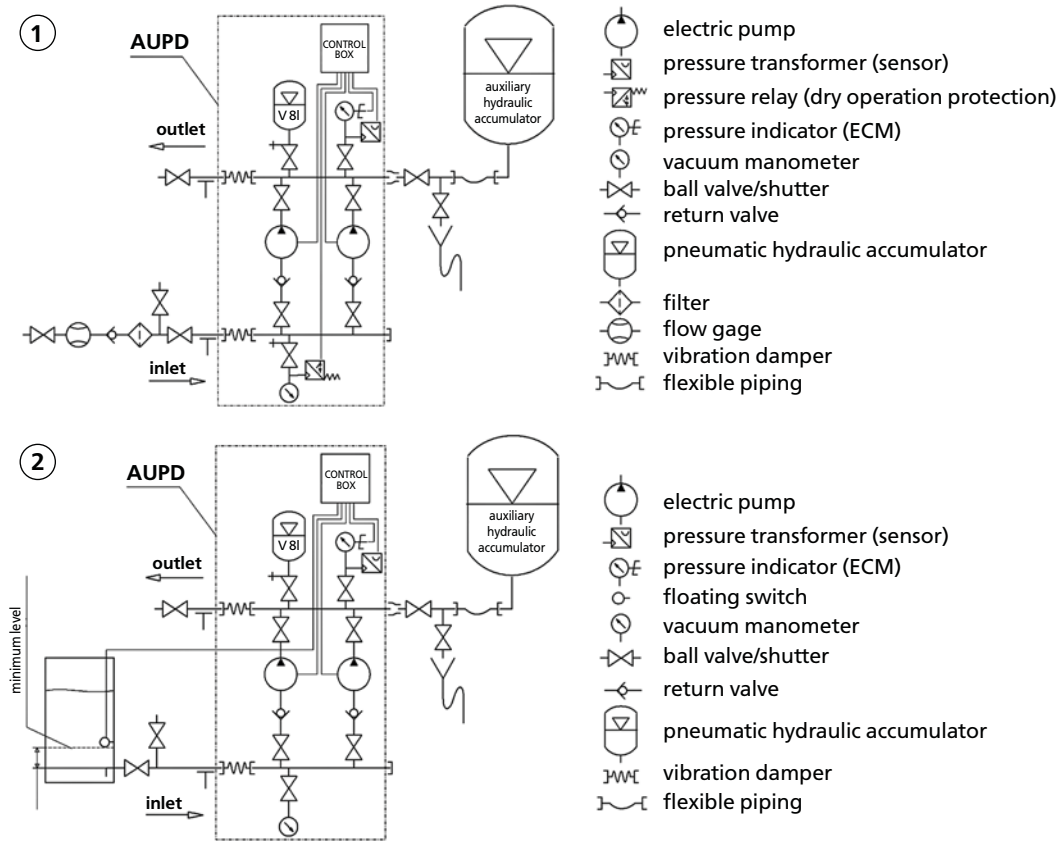

FUNCTIONAL SCHEME. CONNECTION OF AUPD 2 MHN KCHR

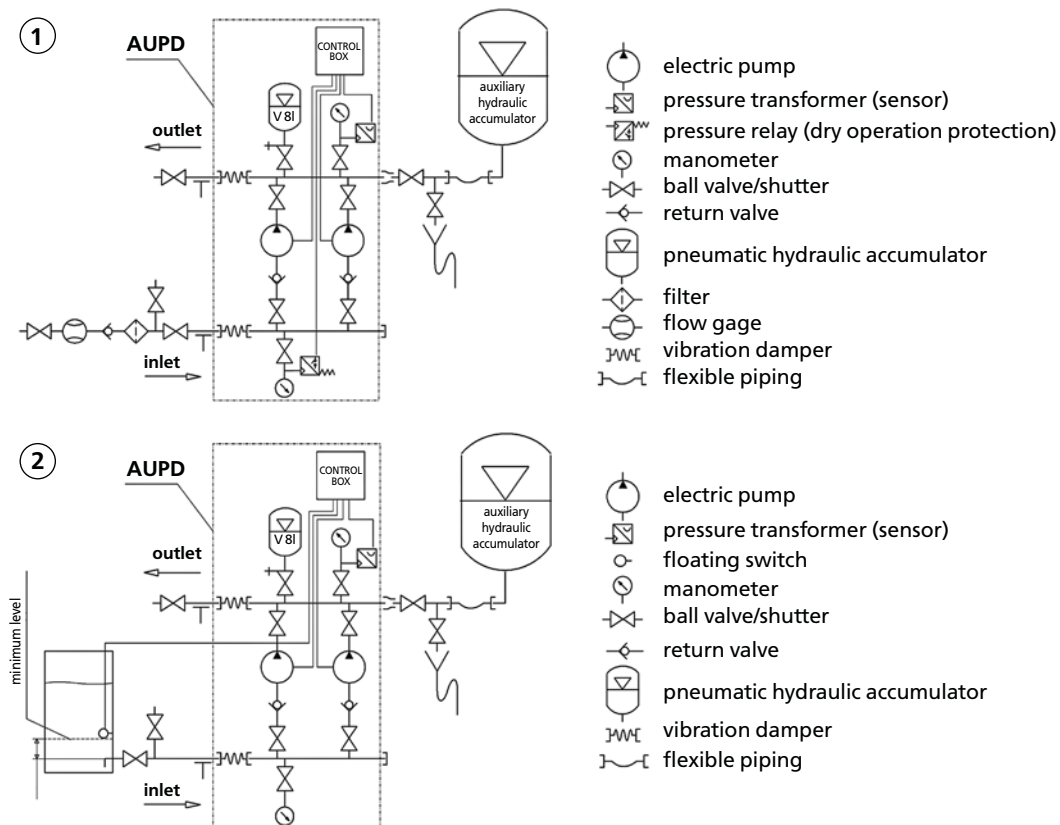

1. Direct connection. 2 Connection to the receiving tank fitting

OVERALL DIMENSIONS AUPD 2 MHN KR/AUPD 3 MHN KR

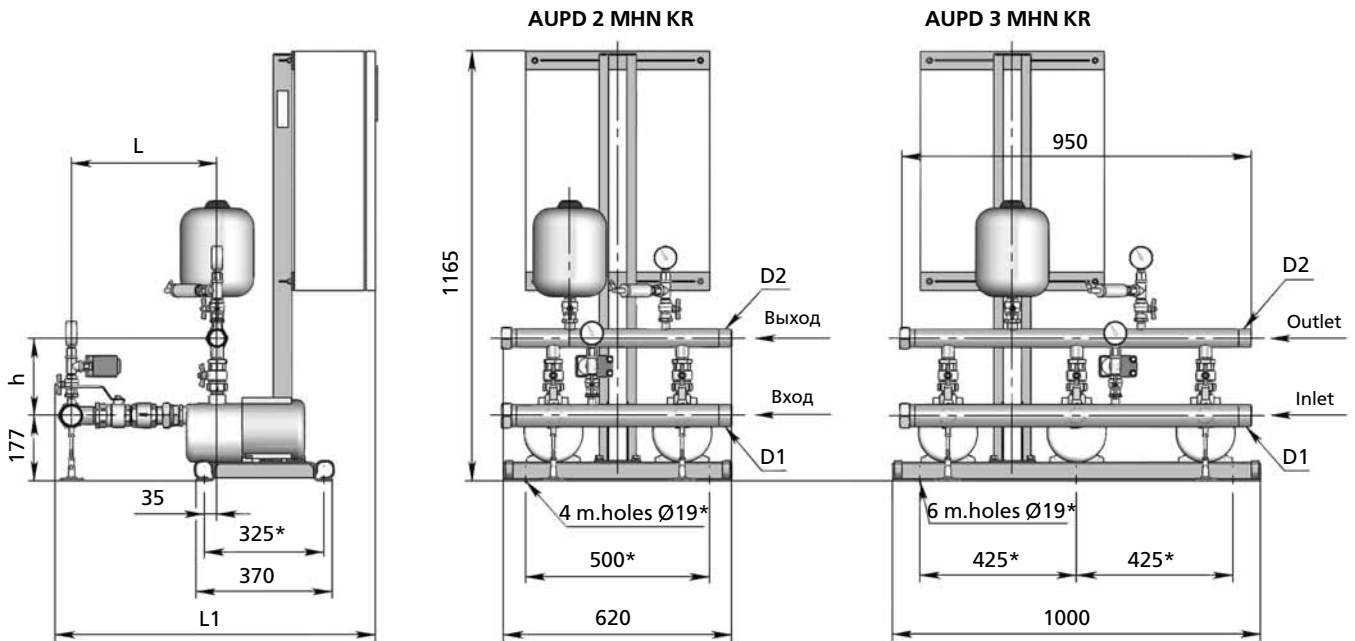

* Sizes of the foundation bolts mounting holes

unit model	D1	D2	dimensions in mm			weight, kg
			L	L1	h	
AUPD 2 MHN 203E KR	G 2	G 1½	395	965	210	85
AUPD 2 MHN 204E KR			420	990		90
AUPD 2 MHN 205E KR			445	1015		95
AUPD 3 MHN 203E KR			395	965		95
AUPD 3 MHN 204E KR			420	990		100
AUPD 3 MHN 205E KR			445	1015		105
AUPD 2 MHN 403E KR	G 2	G 2	395	965	215	90
AUPD 2 MHN 404E KR			420	990		95
AUPD 2 MHN 405E KR			445	1015		100
AUPD 3 MHN 403E KR			395	965		100
AUPD 3 MHN 404E KR			420	990		105
AUPD 3 MHN 405E KR			445	1015		110
AUPD 2 MHN 803 KR	G 2½	G 2½	430	1000	225	105
AUPD 2 MHN 804 KR			460	1030		110
AUPD 2 MHN 805 KR			490	1060		115
AUPD 3 MHN 803 KR			430	1000		125
AUPD 3 MHN 804 KR			460	1030		130
AUPD 3 MHN 805 KR			490	1060		145

OVERALL DIMENSIONS AUPD 2 MHN KCHR

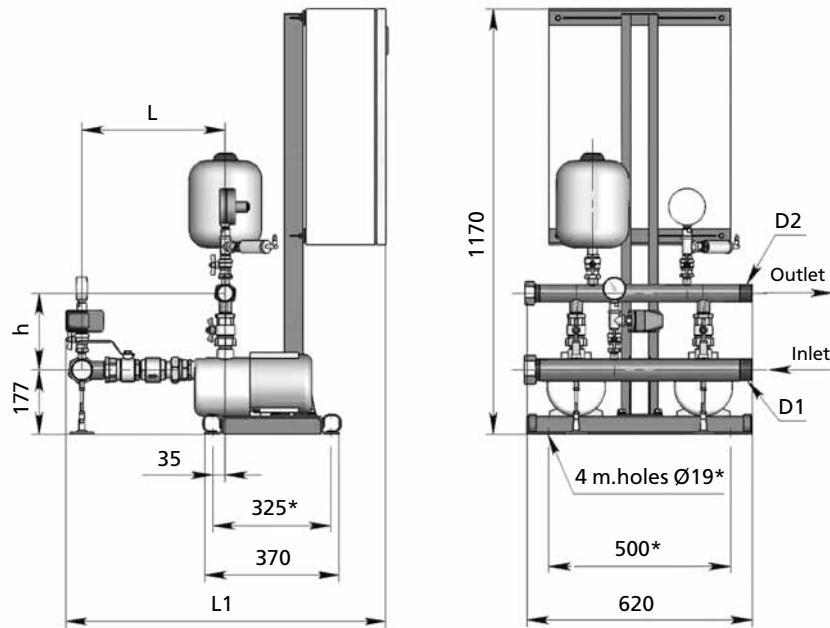

* Sizes of the foundation bolts mounting holes

unit model	D1	D2	dimensions in mm			weight, kg	
			L	L1	h		
AUPD 2 MHN 203E KCHR	G 2	G 1½	395	965	210	85	
AUPD 2 MHN 204E KCHR			420	990		90	
AUPD 2 MHN 205E KCHR			445	1015		95	
AUPD 2 MHN 403E KCHR		G 2	G 2	395	965	215	90
AUPD 2 MHN 404E KCHR				420	990		95
AUPD 2 MHN 405E KCHR				445	1015		100
AUPD 2 MHN 803 KCHR	G 2 ½	G 2 ½	430	1000	225	105	
AUPD 2 MHN 804 KCHR			460	1030		110	
AUPD 2 MHN 805 KCHR			490	1060		115	

PERFORMANCE RANGE

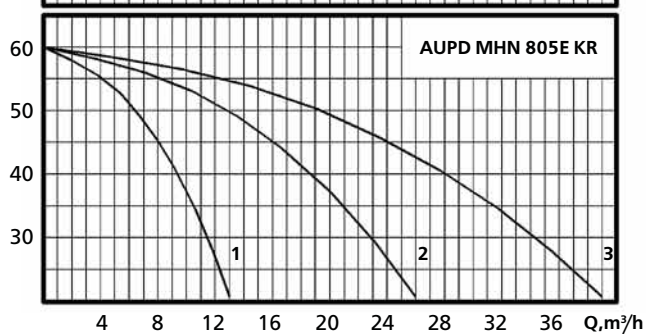
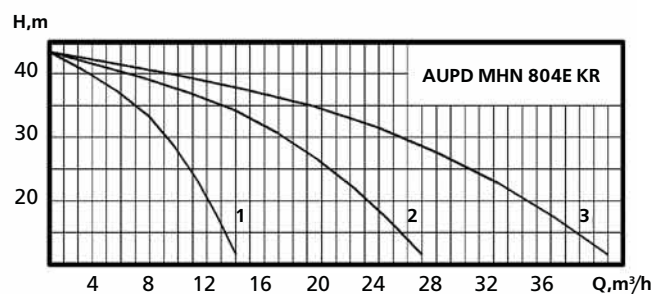
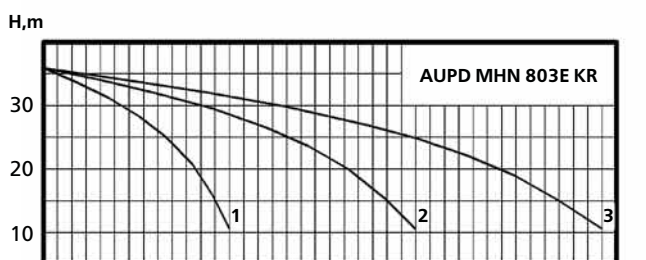
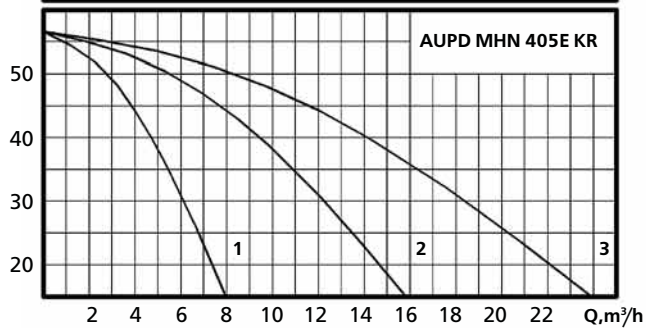
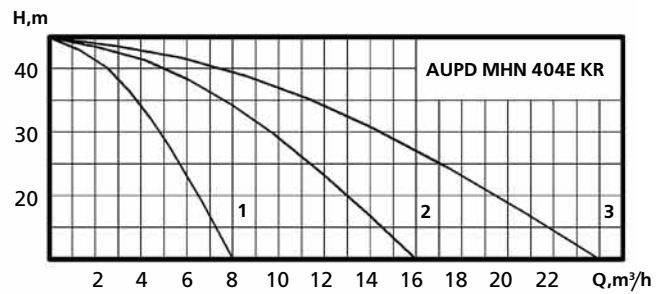
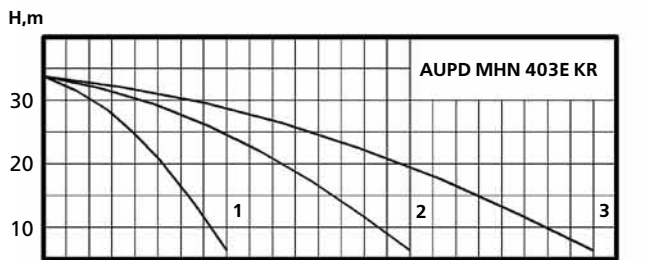
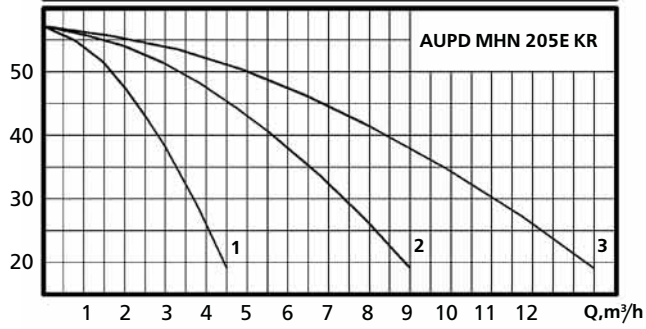
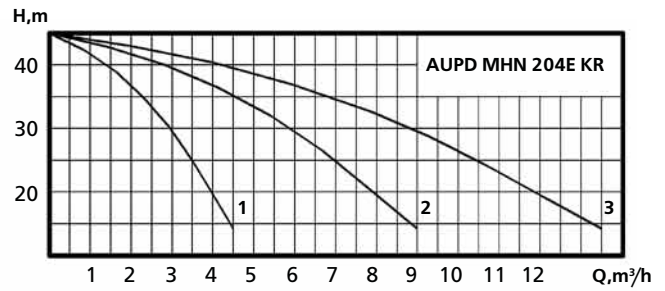
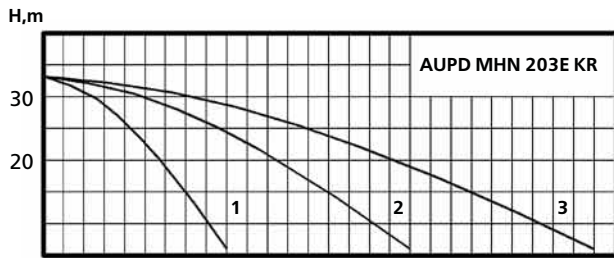

The characteristics are quoted for the cold clean still water. The allowed deviation of water pressure is ± 1 m.

PERFORMANCE RANGE

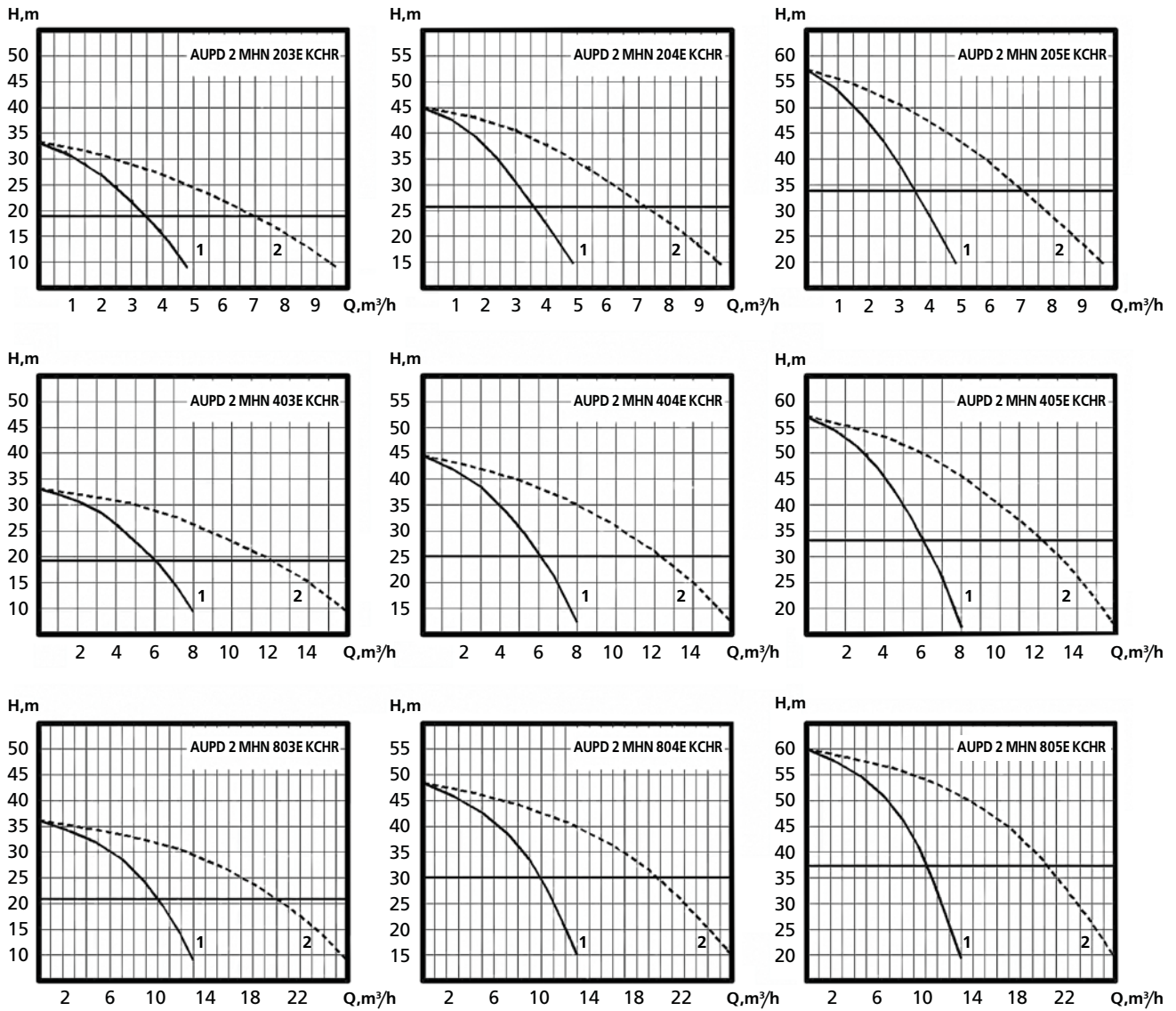

The characteristics are quoted for the cold clean still water. The allowed deviation of water pressure is ± 1 m.

DOMESTIC VIBRATION ELECTRIC PUMPS MALYSH, RUCHEEK

APPLICATION

Electric pumps **Malysh**, **Rucheek** and **Malysh-M** are intended for water lifting from wells and boreholes with the diameter of more than 100 mm from the depth from 0 to 40 meters and electric pump **Malysh-3** from the wells and boreholes with the diameter of more than 80 mm from the depth from 0 to 20 meters, and also, for pumping fresh water from any water bodies with the temperature of water not more than 35 °C. Electric pumps **Malysh**, **Rucheek** and **Malysh-3** are designed with upper water intake, which provides constant cooling of the electromagnetic system protecting it against overheating. Upper water intake eliminates suction of mud from the bottom, and also, water muddiness.

Advantages

- small weight and overall dimensions with low energy costs make it possible to use the pumps for water supply of small cattle farms and field camps, in construction for pumping of water from ditches, trenches, basements and water collectors, for watering of household plots, gardens and individual water supply;
- the electric pumps can be powered by relevant power electric generators and solar generators;
- high reliability and long service life;
- compliance with the safety standards;
- maintenance not required.

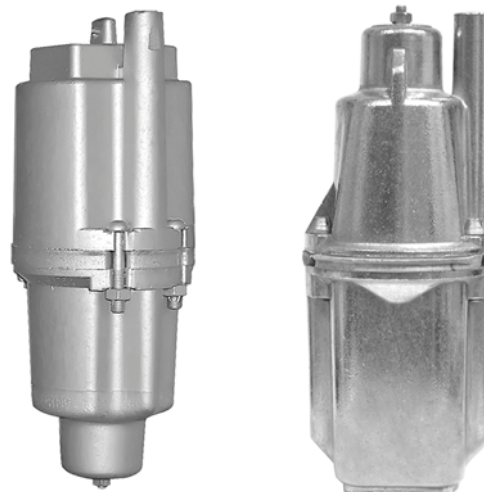

Electric pump with lower water intake

Electric pump with upper water intake

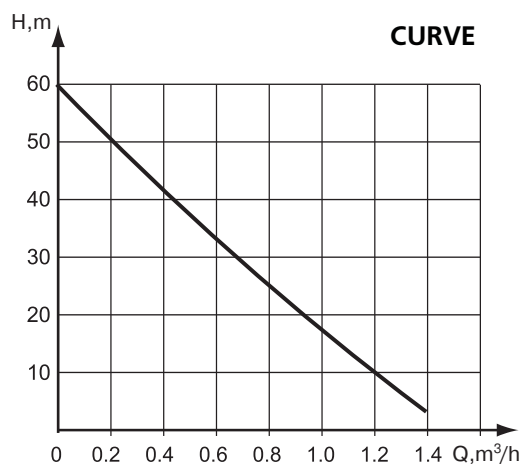

PUMP TYPE KEY

Examples of reference designation:

BV-0.12-20-U5 «MALYSH», **BV-0,12-40** «RUCHEEK»,
BV-0.12-40-U5 «MALYSH-M» и **BV-0.12-20-U5** «MALYSH-3»

domestic

vibration

nominal capacity by volume, l/s

head, m

operating conditions

B V-0.12-XX-U5

TECHNICAL PARAMETERS				
parameter	Rucheek	Malysh	Malysh-M	Malysh-3
nominal voltage, ~ V	220	220	220	220
frequency, Hz	50	50	50	50
consumed power, W, max	300	245	245	165
current, A, max	3.4	3.7	3.7	3.5
water delivery by volume, l/h, from the depth, min:				
— 40 m	432	432	432	-
— 20 m	-	-	-	432
weight, kg, max (without power cord)	3.2	3.5	3.5	3.2
power cord length, m	10, 16, 25, 32, 40, 50			

OVERALL DIMENSIONS

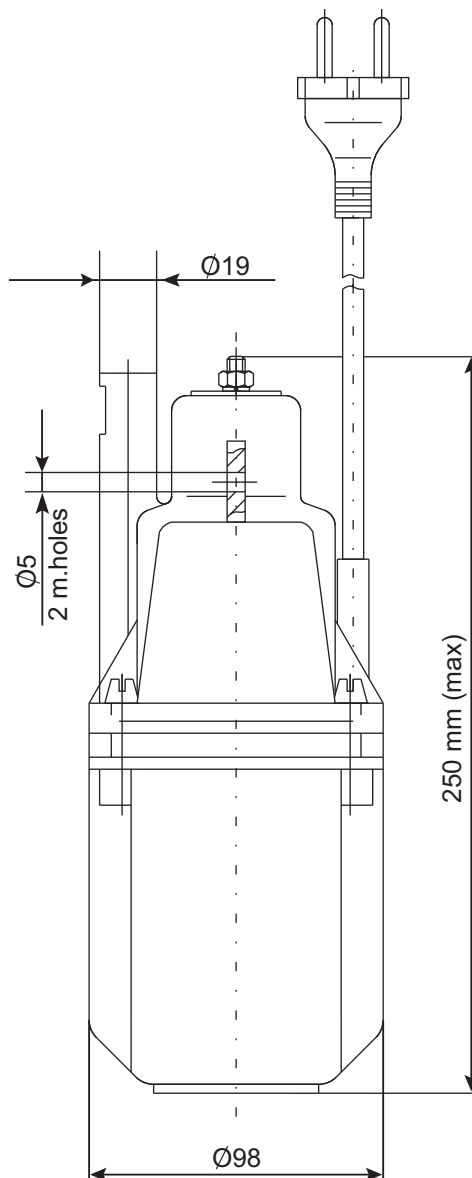

SCHEME OF PUMP INSTALLATION IN A WELL

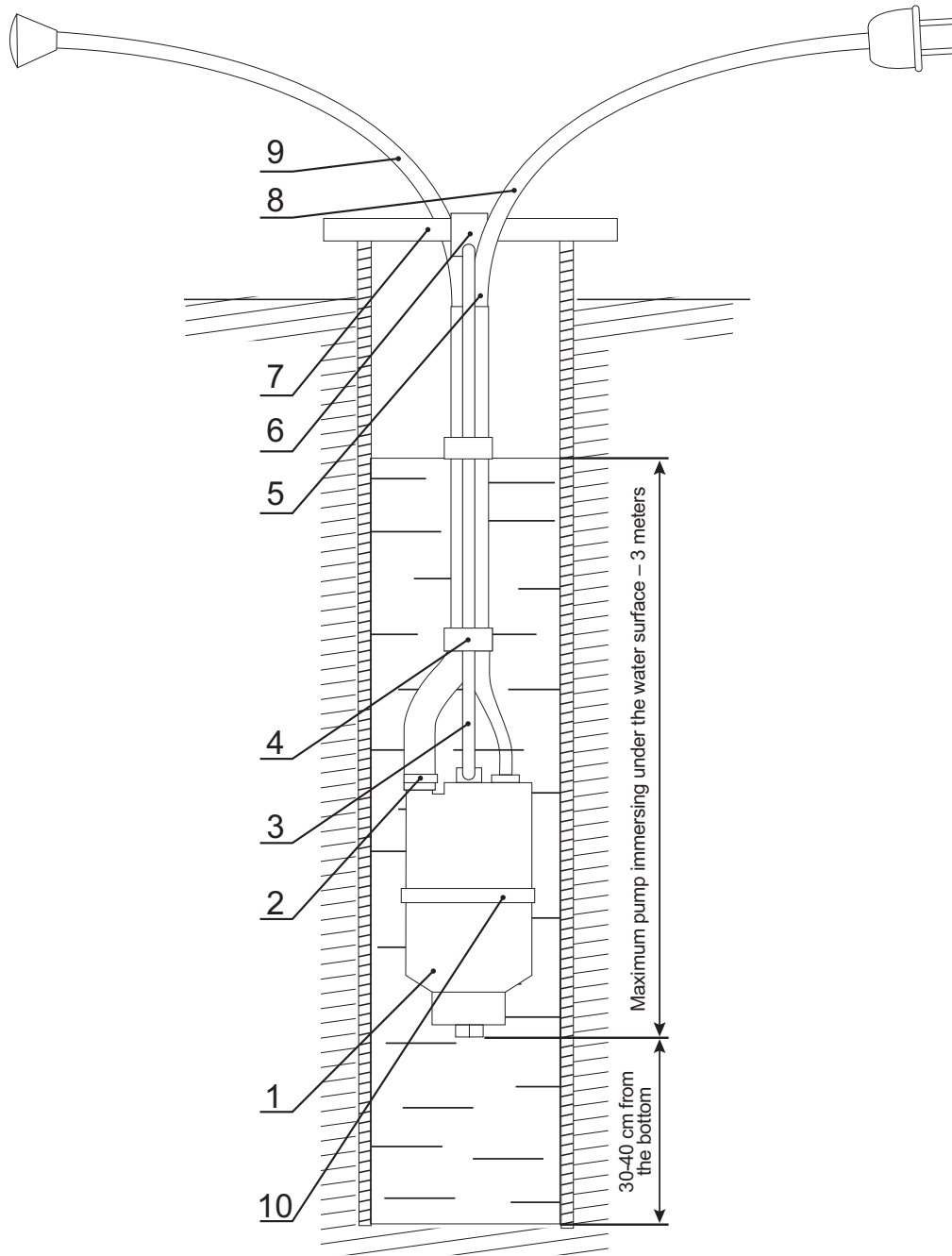

	name		name
1	electric pump	6	rubber spring suspension
2	clip	7	cross bar
3	suspension	8	male plug
4	cord and hose connection	9	hose
5	cord	10	rubber ring (not included in the supply set)

SINGLE-SCREW SELF-PRIMING ELECTRIC PUMPS OF SERIES BURUN®

APPLICATION

Single-screw closed-coupled pumps **BURUN®** are intended for pumping clear water and various liquids and suspensions up to 1000 CP and temperature up to 35 °C when operating in continuous mode and temperature up to 70 °C in periodic mode.

Depending on the necessary delivery or viscosity of the pumped liquid the pumps are equipped with three-phase motors with the rotating speed 3000, 1500, 1000 and 750 rpm for voltage 380V and single-phase motors with the rotating speeds 3000 and 1500 rpm.

Advantages:

As distinguished from centrifugal pumps, screw pumps provide steady non-pulsatile flow of pumped liquid. It eliminates liquid mixing and preserves its structure.

Other advantages of BURUN® pumps:

- high self-priming ability;
- simple design results in pump maintenance convenience. The pump consists of three major parts: stainless screw, rubber block, and shaft sealing;

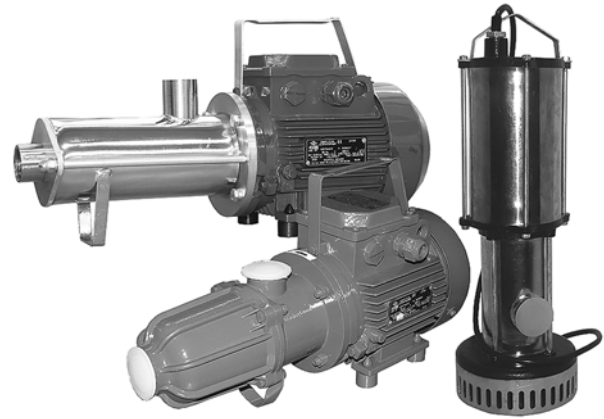

- pump delivery is proportional to the rotating speed. It provides for an easier adjustment of pump parameters if there is a frequency drive;
- pump high pressure with small dimensions is provided by the block design with self-adjusting clearance. The clearance between the screw working surface and the block remains unchanged at increase of pressure.

PUMP TYPE KEY

	BURUN®	X	X / X - X	X / X	TU	26-06-1622-92
series of single-screw pumps						
design version:						
N1V - self-priming, drainage;						
SH - self-priming for slightly aggressive liquids;						
PF - submersible sanitary						
maximal capacity, m ³ /h						
maximum pressure, kgf/cm ³						
motor version: M - multi-phase, 220V;						
no designation – three-phase, 380V						
electric motor power, kW						
number of motor poles:						
2 – 3000 rpm; 4 – 1500 rpm;						
6 – 1000 rpm; 8 – 750 rpm						
designation of technical conditions						

SINGLE-SCREW SELF-PRIMING ELECTRIC PUMPS OF SERIES BURUN® N1V

APPLICATION

Series **N1V** includes portable self-priming drainage pumps. The case parts are made of aluminum and high-duty plastic. The shaft sealing is a standard armored readily-removable collar.

The pump can be used for utility purposes and in industry for pumping water and various nonaggressive liquids with the mechanical impurities and viscosity up to 1000 CP.

The main purpose is drainage of setting and dump pits, watering and irrigation of gardens.



TECHNICAL PARAMETERS

electric pump model	pump pressure, (P max) MPa (kgf/cm ²)	capacity at pressure 0 MPa, m ³ /h	capacity at maximum pump pressure P max MPa, m ³ /h	maximum viscosity, MPa (CP)
N1V 2.5/2-220 BURUN	0.25 (2.5)	3.6	1.2	1000
N1V 2.5/2-380 BURUN	0.25 (2.5)	3.6	1.2	1000

electric pump model	number of phases, power supply	current, A	electric motor		weight, kg
			nominal power, kW	synchronous rotating speed, s ⁻¹ (rpm)	
N1V 2.5/2-220 BURUN	1~ 220. 50	3.7	0.55	50 (3000)	12.5
N1V 2.5/2-380 BURUN	3~ 380. 50	1.8	0.75	50 (3000)	12.2

PERFORMANCE CURVE

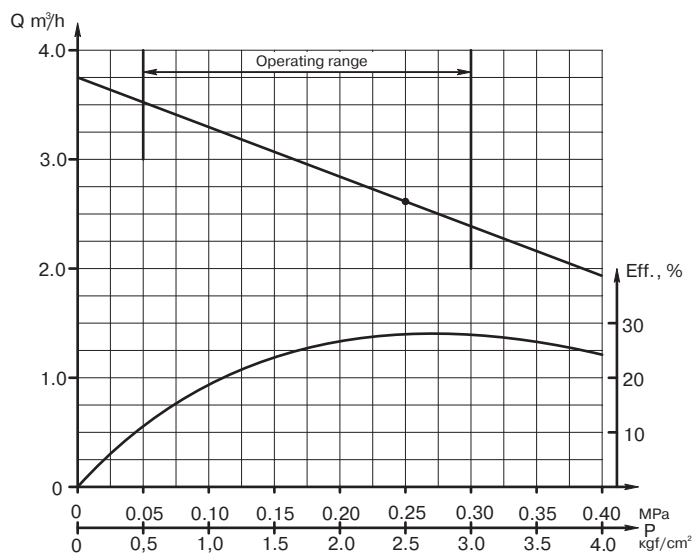

OVERALL DIMENSIONS

Design of electric pump BURUN N1V

1 - case, 2 - pumping screw, 3 - block, 4 - light, 5 - handle, 6 - electric motor, 7 - collar

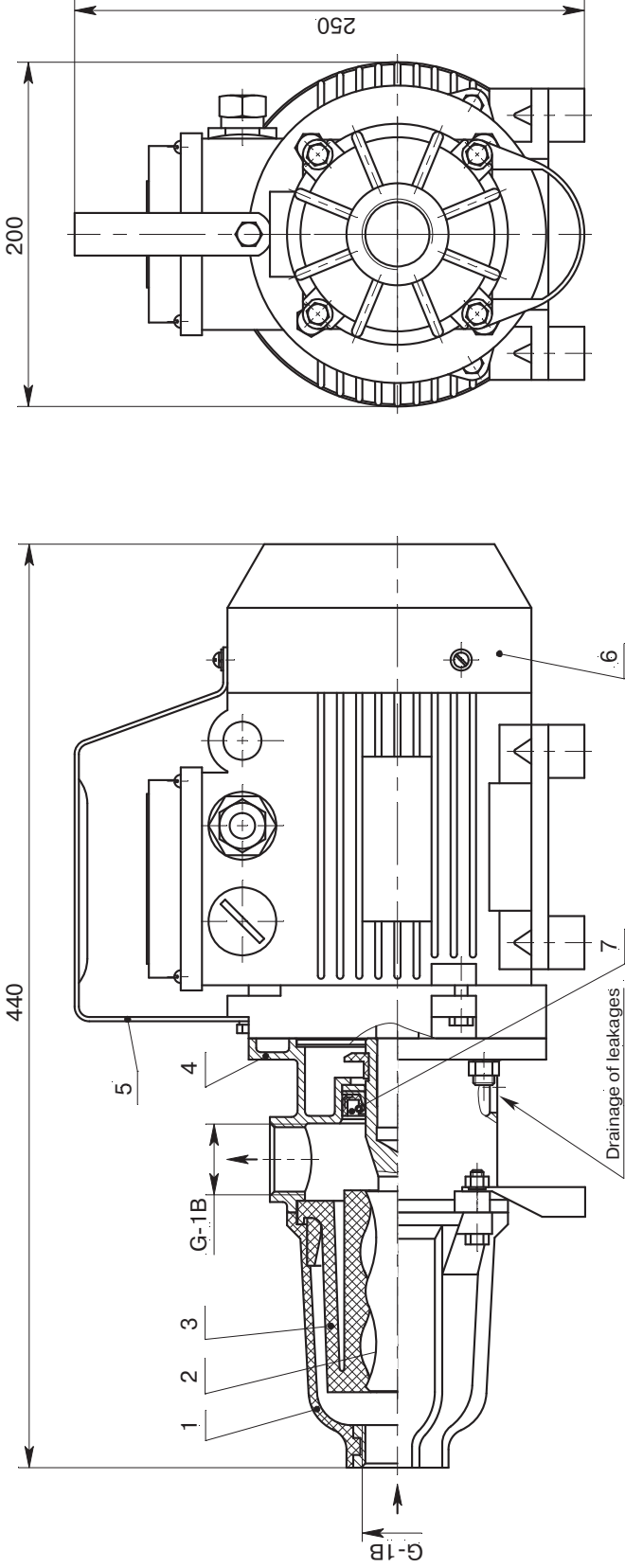

Connection diagram for three-phase version

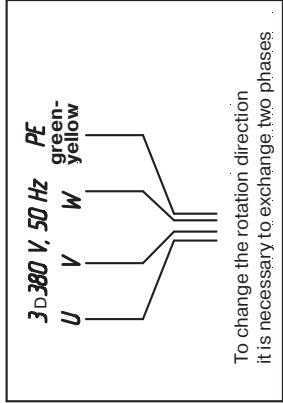

Starting device for single-phase version

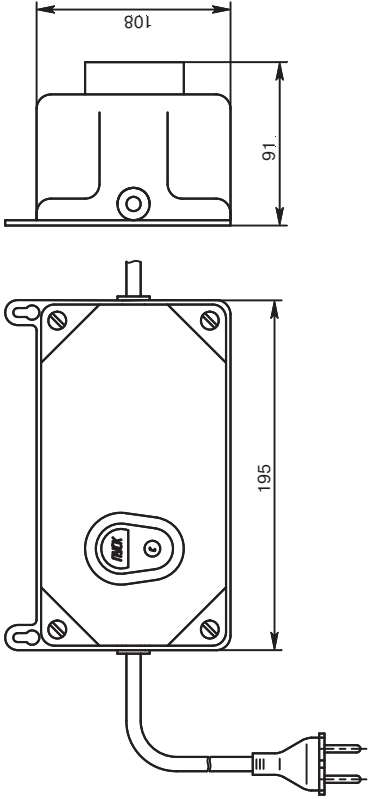

SINGLE-SCREW SELF-PRIMING ELECTRIC PUMPS OF SERIES BURUN® SH

APPLICATION

Electric pump **Burun®** of **SH** series is a portable self-priming pump designed for pumping food products (dough, sour cream, oils, food creams and fillers, jams, honey, conserves etc), paints, cosmetic liquids and creams, detergents, suspended solutions and solutions when their mixing and foaming is undesirable and also, chemically active liquids. The design of this series is intended for use when the pump compact size is important. The pump case and pumping screw are made of stainless steel. The shaft is equipped with imported mechanical face seal. The advantage of this series is its simplicity of design, installation and maintenance.

Depending on the pumped liquid the pump can be equipped with a block strictly corresponding to requirements of operation with food products and cosmetics.

The electric pump has a sanitary-hygienic certificate allowing its use in food and cosmetic industry.

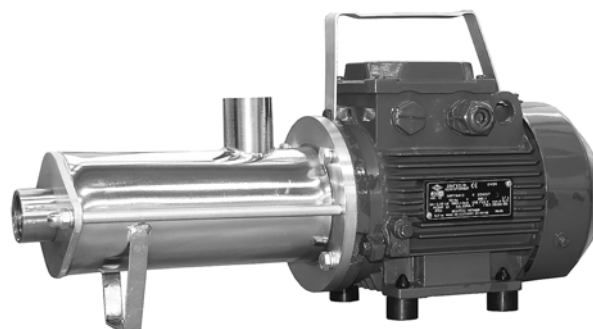

TECHNICAL PARAMETERS

electric pump model	pump pressure, (P max) MPa (kgf/cm ²)	capacity at pressure 0 MPa, m ³ /h	capacity at maximum pump pressure P max MPa, m ³ /h	maximum viscosity, MPa (CP)
BURUN SH 0.9/4-0.25/8	0.4 (4)	0.9	0.4	3000
BURUN SH 1.2/4-0.37/6	0.4 (4)	1.2	0.5	3000
BURUN SH 1.8/4-M0.75/4	0.4 (4)	1.8	0.8	2000
BURUN SH 1.8/4-0.55/4	0.4 (4)	1.8	0.8	2000
BURUN SH 3.6/4-M0.75/2	0.4 (4)	3.2	1.2	1000
BURUN SH 3.6/4-0.75/2	0.4 (4)	3.2	1.2	1000
BURUN SH 6.4/4-1.5/4	0.4 (4)	5.5	2.5	2000

electric pump model	number of phases, power supply	current, A	electric motor		weight, kg
			nominal power, kW	synchronous rotating speed, s ⁻¹ (rpm)	
BURUN SH 0.9/4-0.25/8	3~ 380 V. 50 Hz	1.1	0.25	12.5 (750)	14.0
BURUN SH 1.2/4-0.37/6	3~ 380 V. 50 Hz	1.4	0.37	18.5 (1000)	12.5
BURUN SH 1.8/4-M0.75/4	1~ 380 V. 50 Hz	6.0	0.75	25 (1500)	15.7
BURUN SH 1.8/4-0.55/4	3~ 380 V. 50 Hz	1.7	0.55	25 (1500)	12.5
BURUN SH 3.6/4-M0.75/2	1~ 380 V. 50 Hz	5.7	0.75	50 (3000)	15.2
BURUN SH 3.6/4-0.75/2	3~ 380 V. 50 Hz	1.8	0.75	50 (3000)	13.0
BURUN SH 6.4/4-1.5/4	3~ 380 V. 50 Hz	3.6	1.5	25 (1500)	21.5

PERFORMANCE CURVE

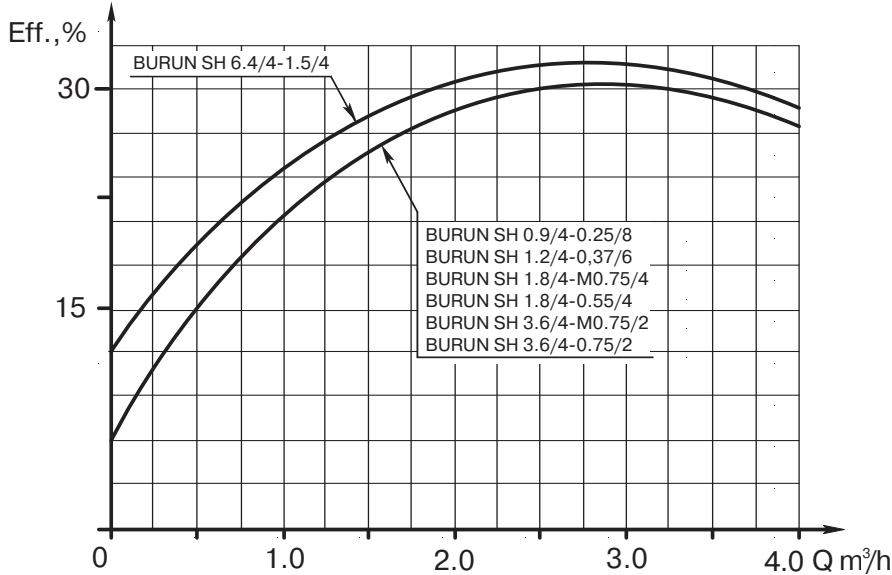
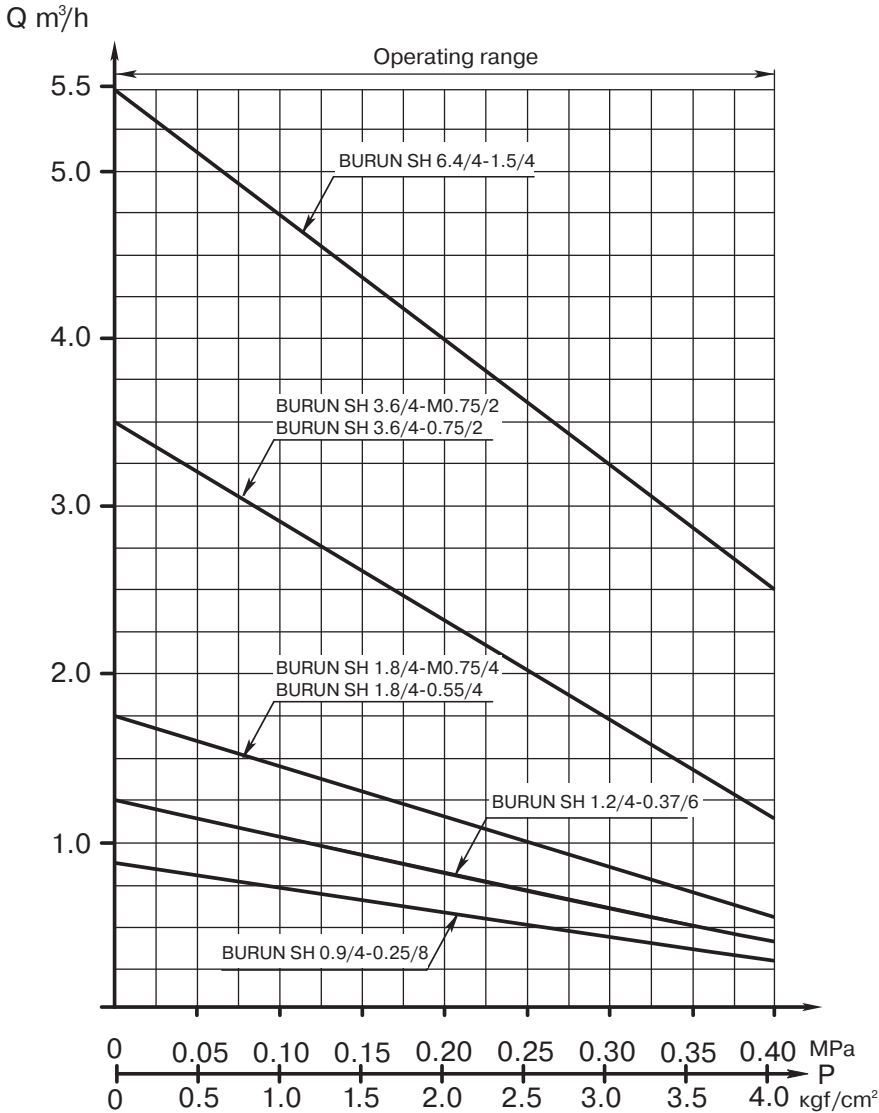

OVERALL DIMENSIONS

Design of electric pump BURUN SH

1 - block, 2 - pump case, 3 - pumping screw, 4 - face seal, 5 - electric motor

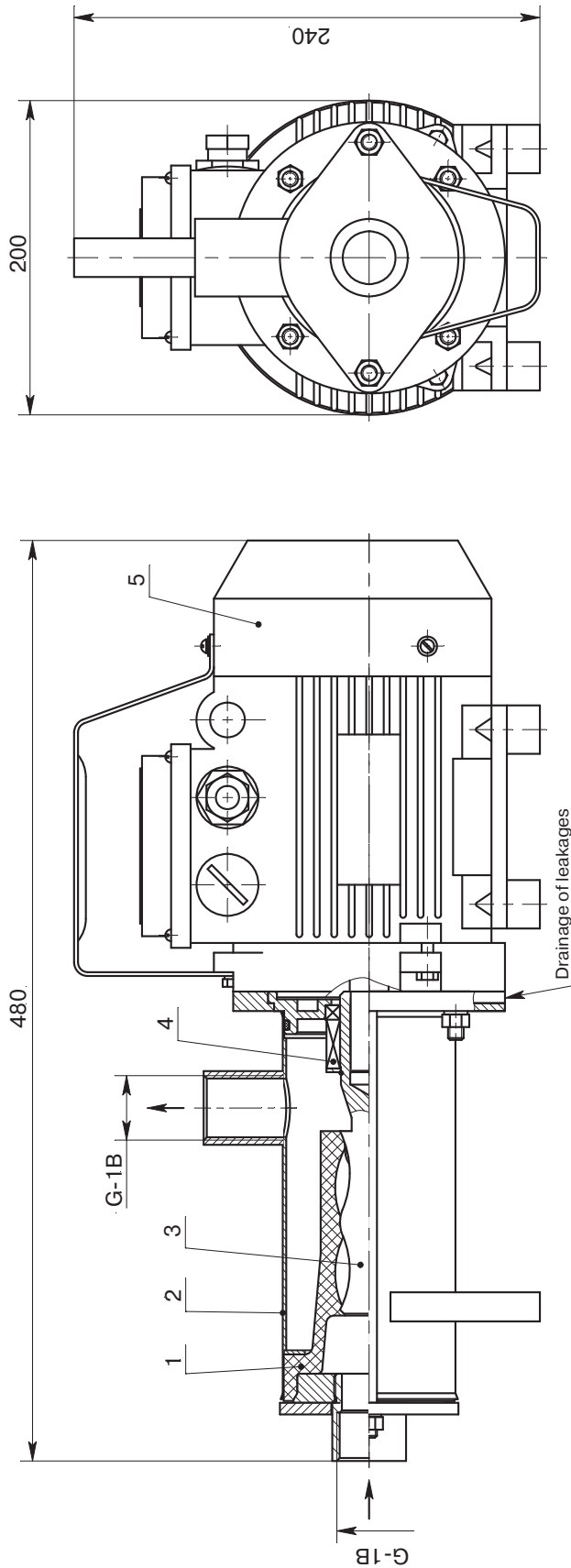

Starting device for single-phase version

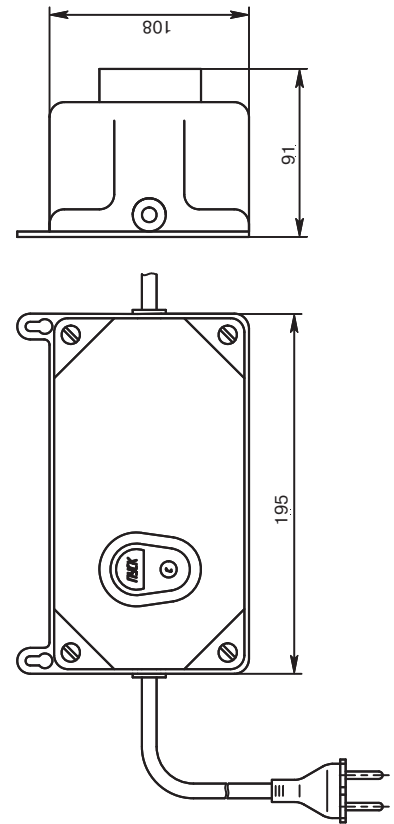

Connection diagram for three-phase version

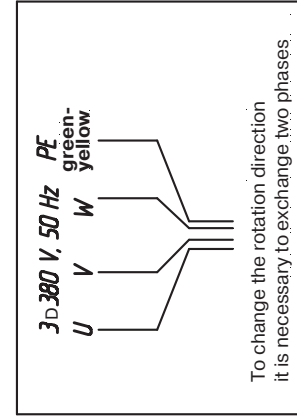

SINGLE-SCREW SELF-PRIMING SUBMERSIBLE ELECTRIC PUMPS OF SERIES BURUN® PF

APPLICATION

Pump of **PF** series is a submersible sanitary pump. The case parts are made of stainless steel. The pump can be used for drainage and sewerage when pumping liquids with high concentration of mechanical and viscous impurities, i.e. in conditions when «Gnom» type pumps can not be used.

The electric pump is not intended for operation in explosion and fire hazardous premises.

The electric pump falls under the category of general purpose products of type 1, repairable under **GOST 27.003-90**.

Climatic version **U** under **GOST-69**. Continuous operating mode.



TECHNICAL PARAMETERS

electric pump model	pump pressure, (P max) MPa (kgf/cm ²)	capacity at pressure 0 MPa, m ³ /h	capacity at maximum pump pressure P max MPa, m ³ /h	maximum viscosity, MPa (CP)
BURUN PF 1.8/4-M0.55/4	0.4 (4)	1.8	0.75	2000
BURUN PF 1.8/4-0.55/4	0.4 (4)	1.8	0.75	2000

electric pump model	number of phases, power supply	current, A	electric motor		weight, kg
			nominal power, kW	synchronous rotating speed, s ⁻¹ (rpm)	
BURUN PF 1.8/4-M0.55/4	1~ 220V, 50Hz	4.0	0.55	25 (1500)	16.5
BURUN PF 1.8/4-0.55/4	3 ~380V, 50 Hz	1.7	0.55	25 (1500)	16

OVERALL DIMENSIONS

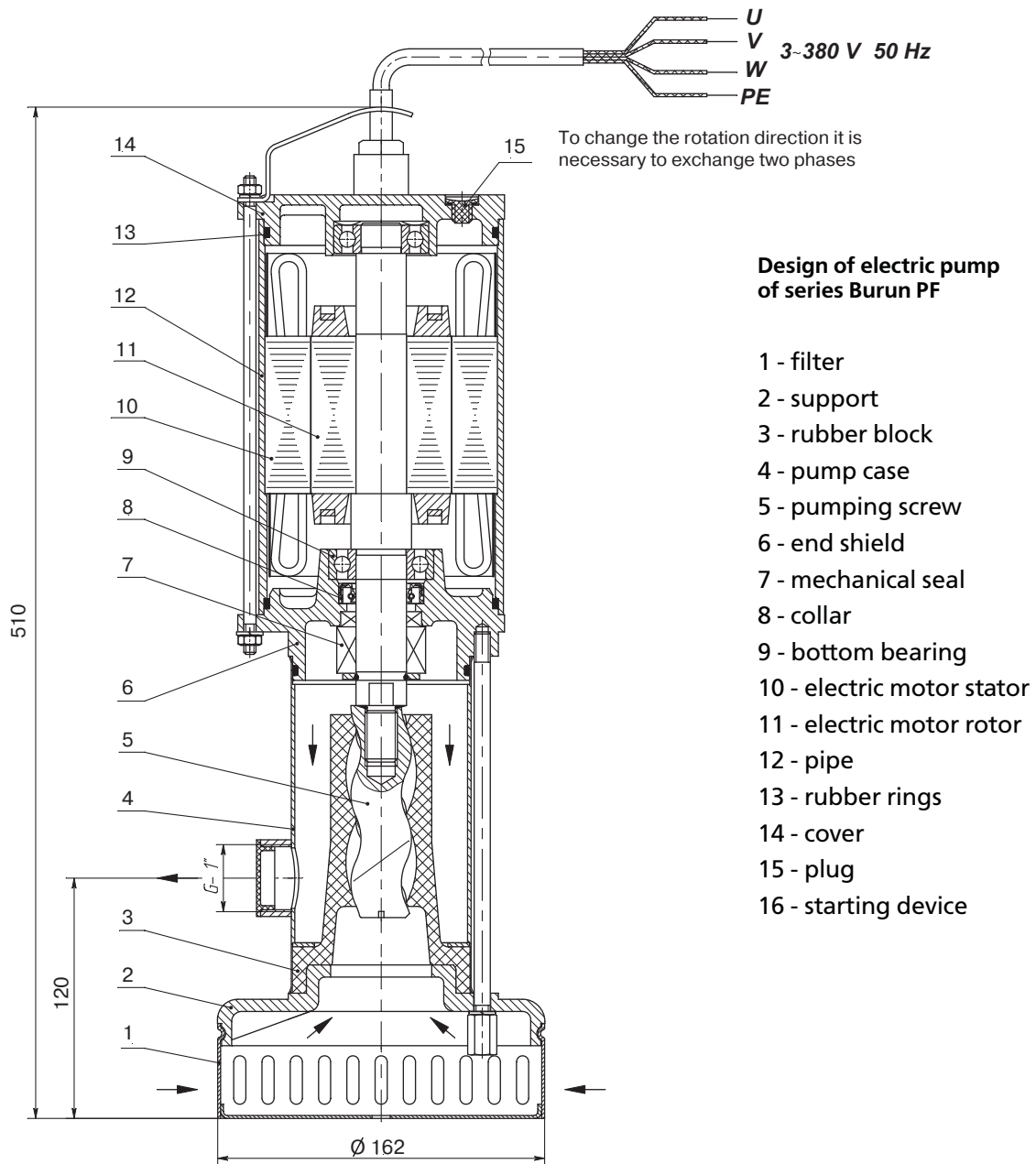

Starting device for single-phase version

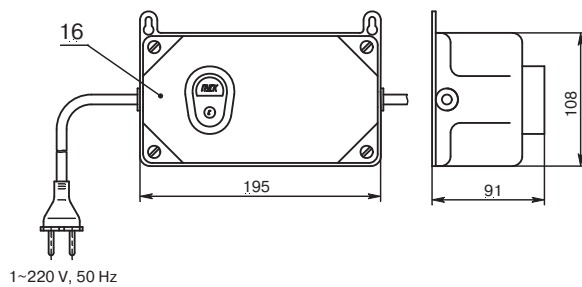

DOMESTIC CENTRIFUGAL SUBMERSIBLE ELECTRIC PUMP OF BCP TYPE

APPLICATION

Domestic centrifugal submersible electric pump of BCP type is intended for supply of water in utility conditions with the total mineral content (dry residue) not more than 1500 g/m^3 , with the hydrogen index $\text{pH}=6.5-9.5$, temperature up to 308 K ($38 \text{ }^\circ\text{C}$), weight fraction of solid mechanical impurities not more than 0.01% , chloride content not more than 1.5 g/m from the wells with the diameter not less than 100 mm and open water bodies.

Distinctive features of BCP electric pumps

Utilization of face seal for protection of electric motor against ingress of sand improves reliability service life of the electric motor bearing units and protects the stator and rotor electromagnetic components against corrosion.

Filling the stator cavity with compound provides electric safety of the electric motor design and good cooling conditions.

A thermal switch is installed in the stator winding protecting the electric motor against overheating in case of blocking pump, slow start, low pressure, etc.

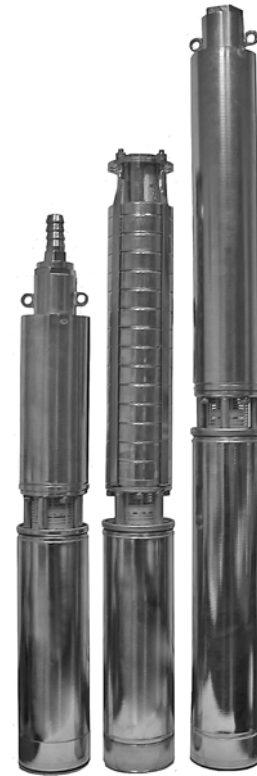

PERFORMANCE RANGE

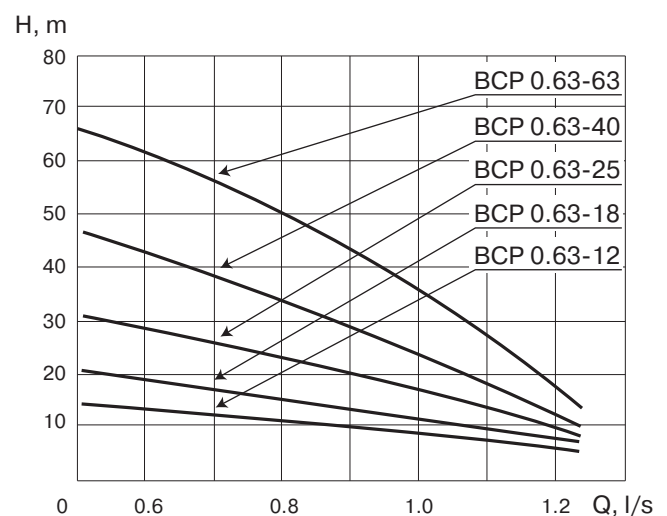
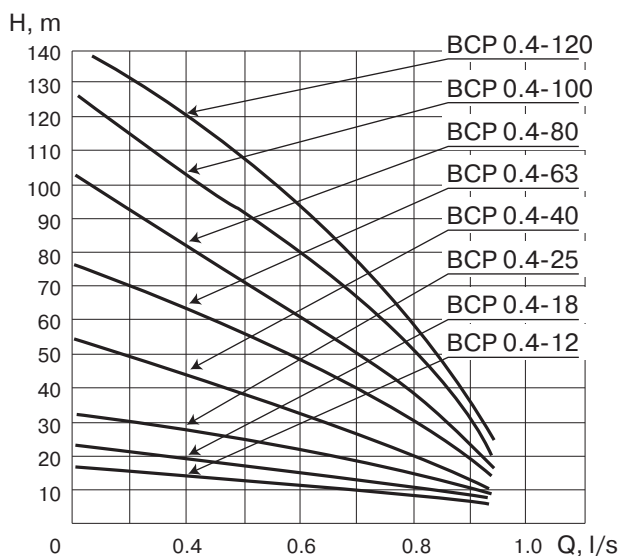

TECHNICAL PARAMETERS

electric pump model	capacity, l/s (m ³ /h)	head, m	voltage, V	consumed power, kW	consumed current A, max
BCP-0.4-12	0.4(1.44)	12	220	0.4	1.8
BCP-0.4-18	0.4(1.44)	18	220	0.5	2.0
BCP-0.4-25	0.4(1.44)	25	220	0.7	3.2
BCP-0.4-40	0.4(1.44)	40	220	0.9	3.85
BCP-0.4-63	0.4(1.44)	63	220	1.35	6.05
BCP-0.4-80	0.4(1.44)	80	220	1.8	8.5
BCP-0.4-100	0.4(1.44)	100	220	2.4	11.0
BCP-0.4-120	0.4(1.44)	120	220	2.6	12.4
BCP-0.63-12	0.63 (2.26)	12	220	0.5	1.7
BCP-0.63-18	0.63 (2.26)	18	220	0.6	2.25
BCP-0.63-25	0.63(2.26)	25	220	0.75	3.2
BCP-0.63-40	0.63(2.26)	40	220	1.2	5.45
BCP-0.63-63	0.63(2.26)	63	220	1.9	9.3

OVERALL DIMENSIONS

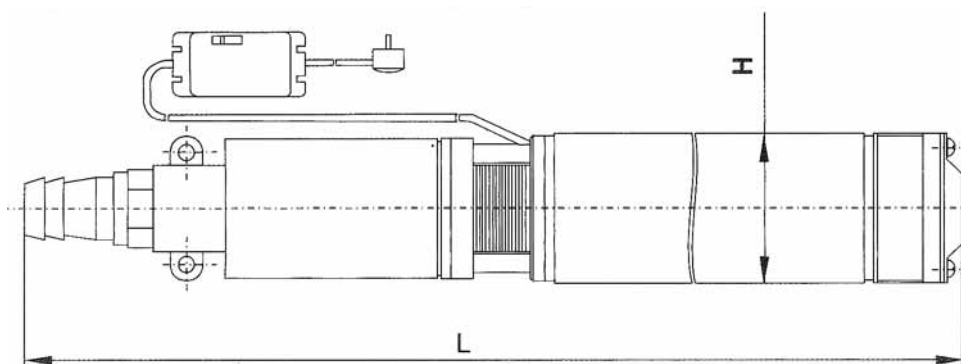

electric pump model	dimension in cross section H, mm, max	length L, mm, max	weight, kg, max
BCP-0.4-12	96	490	15
BCP-0.4-18	96	510	16
BCP-0.4-25	96	570	18
BCP-0.4-40	96	670	21
BCP-0.4-63	96	770	27
BCP-0.4-80	96	960	43
BCP-0.4-100	96	1055	49
BCP-0.4-120	96	1125	55
BCP-0.63-12	96	485	15
BCP-0.63-18	96	545	16
BCP-0.63-25	96	580	18
BCP-0.63-40	96	690	23
BCP-0.63-63	96	900	40

field of application pumps type	clear water supply	hot water supply	water supply from wells	pumping contaminated water	sewage	waste waters	irrigation of gardens and agricultural lands	construction and drainage works
D	*						*	
DNA	*						*	*
ECV, 2ECV			*					
CNSg	*	*						
CNSv	*	*						
K, 1K, 2K	*	*						
KM, 1KM	*	*						
1KML, KML		*						
VK, VKS, VKO	*							
CVK	*	*						
SM, SMS				*	*	*		
CMF				*	*	*		
GNOM	*			*		*		*
N1V				*	*	*		*
AUPD	*	*						
Malysh, Rucheek	*		*				*	
BURUN	*						*	
BCP			*				*	

end-suction pumps

from 1973	from 1982	from 1990
1,5 K-6	K8/18	K50-32-125
1.5KM-6	KM8/18	KM50-32-125
2 K-6	K20/30	K65-50-160
2KM-6	KM20/30	KM65-50-160
3K-9	K45/30	K80-65-160
3K-6	K45/55	K80-50-200
3KM-6	KM45/55	KM80-50-200
4K-18	K90/20	K90/20
4K-12	K90/35	K100-80-160
4KM-12	KM90/35	KM100-80-160
4K-8	K90/55	K100-65-200
4KM-8	KM90/55	KM100-65-200
4 K-6	K90/85	K100-65-250
4KM-6	KM90/85	KM100-65-250
6K-12	K160/20	K150-125-250
6KM-12	KM 160/20	KM150-125-250
6K-8	K160/30	K150-125-315
8K-18	K290/18	K200-150-250
8K-12	K290/30	K200-150-315

double-side inlet pumps

from 1973	from 1982	from 1990
5NDv	D200-36	D200-36
4NDv	D200-95	1D200-90
—	D250-130V	1D250-125
6NDv	D320-50	1D315-50
6NDs	D320-70	1D315-71
10D-6	D500-65	1D500-63
8NDv	D630-90	1D630-90
12D-9	D800-57	1D800-56
12NDs	D1250-65	1D1250-63
14D-6	D1250-125	1D1250-125
14NDs	D1600-90	1D1600-90
16NDn	D2000-21	2D2000-21
16NDn	D2000-21	D2000-21-2
20D-6	D2000-100	D2000-100-2
18NDs	D2500-62	D2500-62-2
20NDn	D3200-33	D3200-33-2
20NDs	D3200-75	D3200-75-2
22NDs	D4000-95	D4000-95-2
24NDv	D5000-32	D6300-27-3-1
32D-19	D6300-27	D6300-27-3
24NDs	D6300-80	D6300-80-2

horizontal multi-stage pumps

from 1973	from 1982	from 1990
3MS(G)-10x2	CNS(G) 38-44	CNS(G) 38-44
3MS(G)-10x3	CNS(G) 38-66	CNS(G) 38-66
3MS(G)-10x4	CNS{G} 38-88	CNS(G) 38-88
3MS(G)-10x5	CNS(G) 38-110	CNS(G)38-110
3MS(G)-10x6	CNS(G) 38-132	CNS(G) 38-132
3MS(G)-10x7	CNS(G) 38-154	CNS(G) 38-154
3MS(G)-10x8	CNS(G) 38-176	CNS(G) 38-176
3MS(G)-10x9	CNS(G) 38-198	CNS(G) 38-198
3MS(G)-10x10	CNS(G) 38-220	CNS(G) 38-220
4MS(G)-10-2x2	CNS(G) 60-66	CNS(G) 60-66
4MS(G)-10-2x3	CNS(G) 60-99	CNS(G) 60-99
4MS(G)-10-2x4	CNS(G) 60-132	CNS(G) 60-132
4MS(G)-10-2x5	CNS(G) 60-165	CNS(G) 60-165
4MS(G)-10x6	CNS(G) 60-198	CNS(G) 60-198
4MS(G)-10x7	CNS(G) 60-231	CNS{G} 60-231
4MS(G)-10x8	CNS(G) 60-264	CNS(G) 60-264
4MS(G)-10x9	CNS(G) 60-297	CNS(G) 60-297
4MS(G)-10x10	CNS(G) 60-330	CNS(G) 60-330
5MS-10x2	CNS 105-98	CNS 105-98
5MS-10x3	CNS 105-147	CNS 105-147
5MS-10x4	CNS 105-196	CNS 105-196
5MS-10x5	CNS 105-245	CNS 105-245
5MS-10x6	CNS 105-294	CNS 105-294
5MS-10x7	CNS 105-343	CNS 105-343
5MS-10x8	CNS 105-392	CNS 105-392
5MS-10x9	CNS 105-441	CNS 105-441
5MS-10x10	CNS 105-490	CNS 105-490
6MS-7x2	CNS 180-85	CNS 180-85
6MS-7x3	CNS 180-128	CNS 180-128
6MS-7x4	CNS 180-170	CNS 180-170
6MS-7x5	CNS 180-212	CNS 180-212
6MS-7x6	CNS 180-255	CNS 180-255
6MS-7x7	CNS 180-297	CNS 180-297
6MS-7x8	CNS 180-340	CNS 180-340
6MS-7x9	CNS 180-383	CNS 180-383
6MS-7x10	CNS 180-425	CNS 180-425
8MS-7x2	CNS 300-120	CNS 300-120
8MS-7x3	CNS 300-180	CNS 300-180
8MS-7x4	CNS 300-240	CNS 300-240
8MS-7x5	CNS 300-300	CNS 300-300
8MS-7x6	CNS 300-360	CNS 300-360
8MS-7x7	CNS 300-420	CNS 300-420
8MS-7x8	CNS 300-480	CNS 300-480
8MS-7x9	CNS 300-540	CNS 300-540
8MS-7x10	CNS 300-600	CNS 300-600
3V-200x2	CN 400-105	CN 400-105
3V-200x4	CN 400-210	CN 400-210
10NMKx2	CN1000-180	CN1000-180-3

QUESTIONNAIRE FORM FOR ORDERING PUMPING EQUIPMENT

To place order you are requested to fill and send us the questionnaire form.

6a, 3-rd Pryadilnaya st., Moscow, 105037, Russia. Tel.: +7 (495) 730-0207 Fax: +7 (495) 730-0236 e-mail: hydro@hms.ru www.hms.ru

Manufacturing plant: _____

Item	parameter (feature)	units of measure	customer requirement
1	FUNCTIONAL		
1.1	capacity	m ³ /h	
1.2	head	m	
1.3	Inlet/outlet pressure (max)	kgf/cm ²	
1.4	pump suction head (max)	m	
1.5	for semi-immersed (submersible) pumps		
1.5.1	maximum self-priming height (for self-priming pumps)	m	
2	PUMPED MEDIA		
2.1	solid particles content:		
2.1.1	volume concentration	%	
2.1.2	size of particles (abrasive/nonabrasive)	mm	
2.2	operating temperature	°C	
2.3	viscosity (kinematic) at to	cSt (m ² /s)	
2.4	density at to	kg/cm ³	
2.5	saturated steam absolute pressure	kgf/cm ²	
2.6	explosion hazard category and group of explosion hazardous mixtures under GOST 12.1.011 (annex 3)		
3	MATERIALS RESISTANT IN THE PUMPED MEDIA		
	- steel 20H13L, 12H18N9T, 35L or other - tin bronze - SCH20 - rubber IRP 1225, IRP 1314		
4	SHAFT SEALING		
4.1	gland single/double (S/SD)		
4.2	mechanical single/double (5/55)		
5	OPERATION (INSTALLATION) CONDITIONS		
5.1	climatic version and location category for operation under GOST 15150-69		
5.2	class of explosion hazard and fire preventive location zone under electrical safety rules		
5.3	necessity of cooling/heating media supply	yes/no	
6	DRIVE		
6.1	voltage, number of phases		
6.2	line frequency		
7	ANNEX: installation diagram, other requirements		

Filled by: _____ Title: _____

Address: _____

Phone: _____ Fax: _____

Information in this catalog is given for reference only and makes it possible to select necessary products designed and manufactured by the enterprises of HMS Group. Full technical information on all the products is given in the relevant technical manuals. It is this information that shall determine inclusion in any projects, assembly, and operation of the products manufactured by the enterprises of HMS Group.

The enterprises of HMS Group reserve the right to modify their products and change the catalog of products without prior notice. The enterprises of HMS Group are not responsible for any printing errors in the catalogs, booklets, and other promotion and information materials.

6a, 3-rd Pryadilnaya st.,
Moscow, 105037, Russia

Phone: + 7 (495) 730 0219, 730 0212
Fax: + 7 (495) 730 0236

e-mail: hydro@hms.ru
www.grouphms.com
www.hms.ru