



- 01 -

- 02 -

- 03 -

- 04 -

- 05 -

- 06 -

- 07 -

Pumps

• End Suction Centrifugal Pump

 利欧集团浙江泵业有限公司
LEO GROUP PUMP(ZHEJIANG) CO.,LTD. (Stock code: 002131)

No.1, 3rd Street, East Industry Center, Wenling, Zhejiang, China, 317500
Tel: +86-576-8998 6360 Fax: +86-576-8998 9898 E-mail: export@leogroup.cn www.leogroup.cn

www.leogroup.cn

利欧集团浙江泵业有限公司
LEO GROUP PUMP(ZHEJIANG) CO.,LTD.



www.leogroup.cn

HISTORY

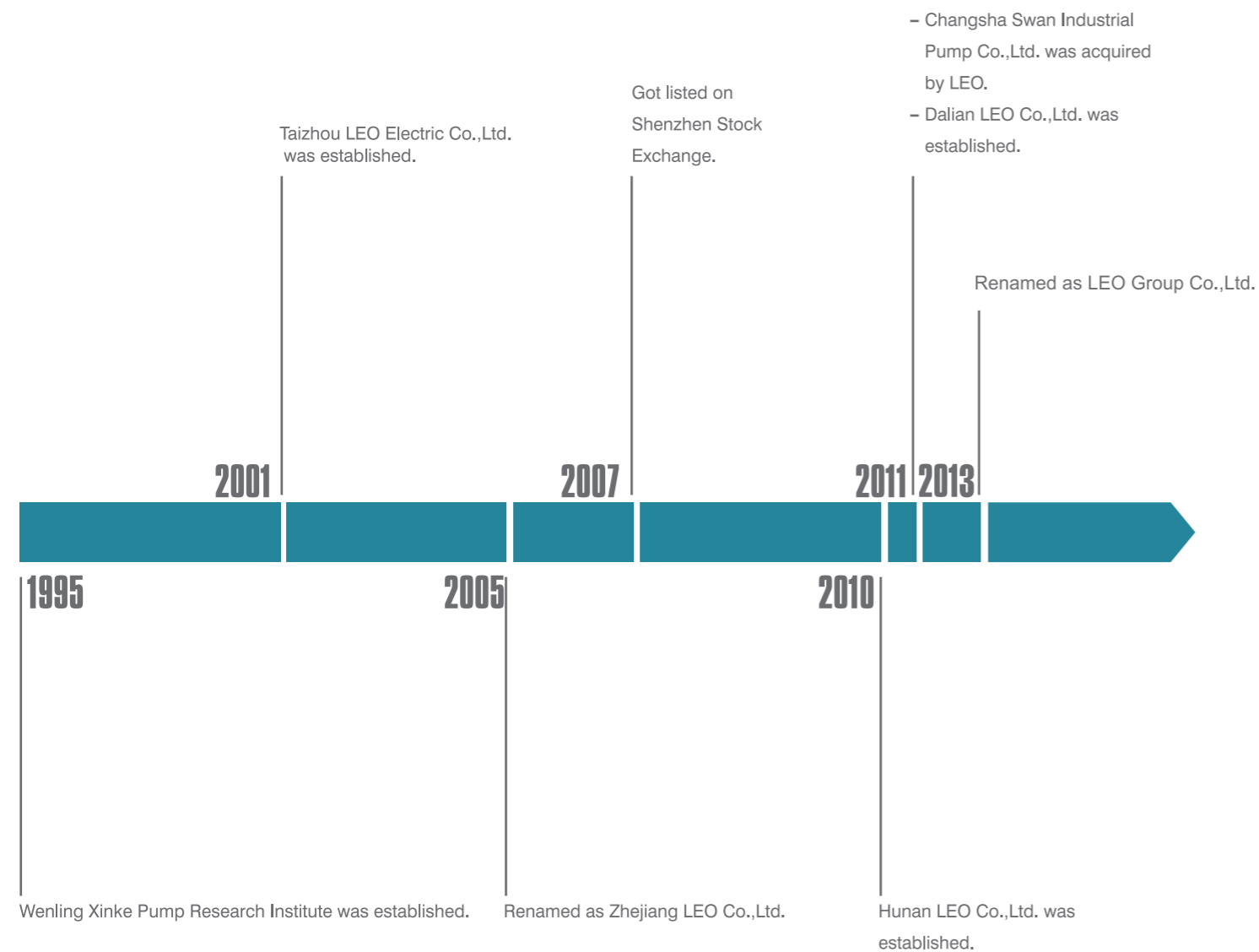

TO KNOW LEO

LEO Group (got listed in Shenzhen Stock Exchange with stock code 002131) is a national high-tech enterprise engaged in R&D, design , manufacture, sales and service of all series pump. LEO is the first listed company in Chinese pump industry, one of the drafters of pump industry standard and the vice president of drainage and irrigation machinery branch of China Agricultural machinery industry association as well. It is mentionable that LEO has the only state-authorized technical center in this industry.

Our products have been sold to over 120 countries and regions, such as Europe, North America, Central &South America, Southeast Asia, Middle East, Africa, Oceania ,etc., which play a crucial role in water conservancy , water resources, electric power construction, petrochemical industry, mining, metallurgy, fire-fighting, HVAC(Heating, Ventilation and Air Conditioning), agricultural irrigation, civil water supply and drainage, etc.

LEO has currently two industrial groups respectively for industrial and civilian applications. With five manufacturing bases in Wenling of Zhejiang, Xiangtan of Hunan, Changsha of Hunan, Wuxi of Jiangsu and Dalian of Liaoning, LEO possesses a solid foundation to become a world-class pump and system solution provider rapidly.

With over 70 years' professional technology, LEO will continue her consistent creativity and development ability in each pump for human's health.

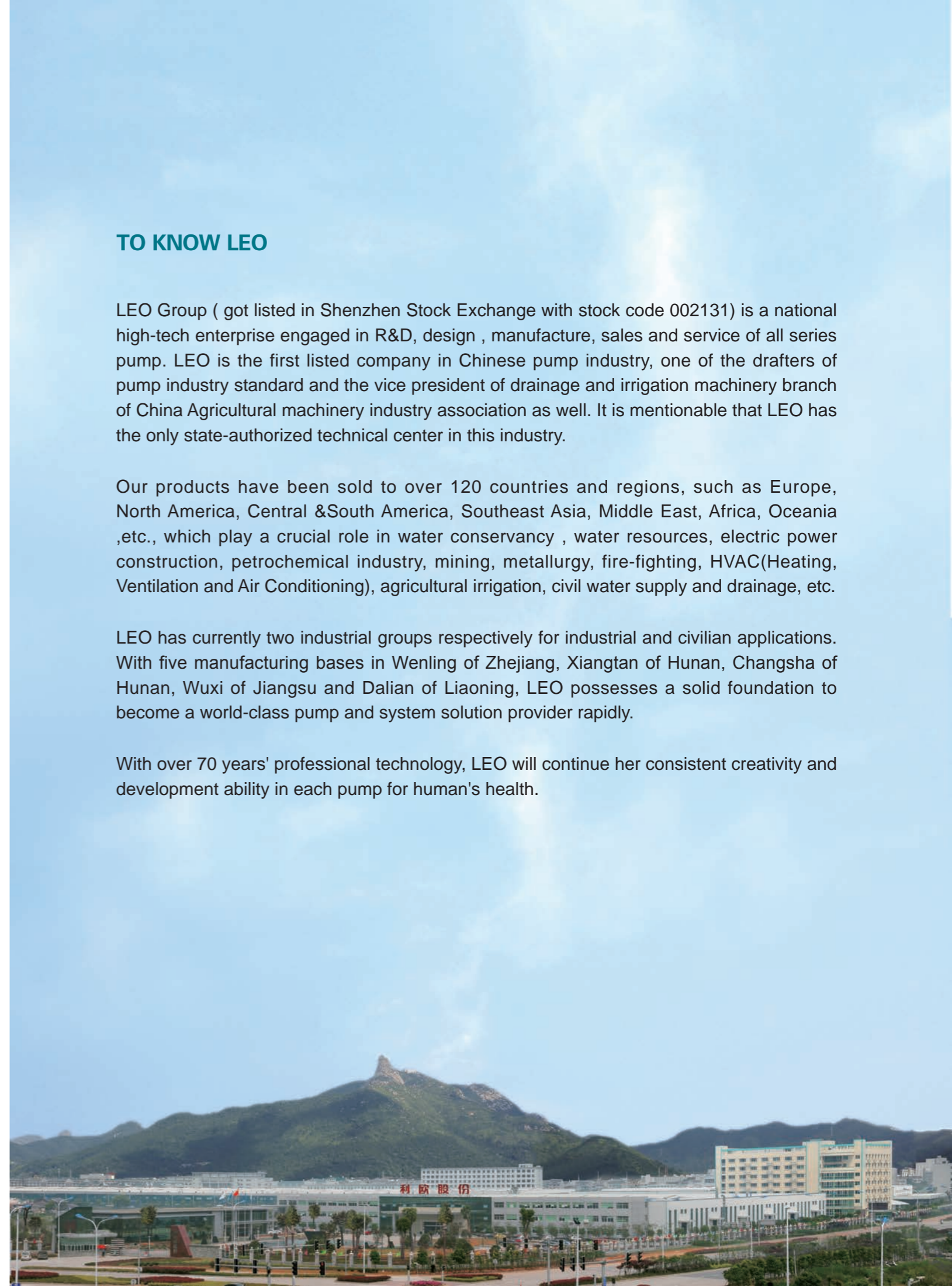

NUMEROUS MEMBERS, ONE FAMILY

Based on market segment, LEO's pump business is divided into 5 fields, namely water conservancy & water resources, power station, petrochemical industry, mining & metallurgical industry and civilian applications. For each field there's a professional manufacturing base with relevant professional sales teams. Four subsidiary companies – Wuxi LEO Xi Pump, Changsha LEO Swan Pump, Dalian LEO Huaneng Pump and Hunan LEO Pump are all well-known industrial pump manufacturers in their own fields. With over 70 years' industrial pump manufacturing experience and extraordinary comprehensive strength, LEO becomes a leading company among all industrial pump manufacturers in China.



Pump Manufacturing Base for Domestic and Commercial Applications (Wenling City, Zhejiang Province)

It is the core base for R&D, manufacturing, sales and service of domestic and commercial pumps for family water supply, pipeline boosting, garden and field irrigation, HVAC, etc.

The leading products include peripheral pump, jet pump, centrifugal pump, garden submersible pump, fountain pump, pool pump, domestic lifting station, gasoline engine pump, diesel engine pump, submersible pump, submersible borehole pump, submersible sewage pump, stainless steel vertical multistage pump, etc.

The product range covers 15 series with over 2,000 specifications, which are well sold in more than 120 countries and regions. The base has established steady cooperative relationships with world-class pump manufacturers, importers, dealers and hypermarkets.



Pump Manufacturing Base for General Industrial Pumps (Xiangtan City, Hunan Province)

It is the most important base for industrial pumps.

The products are mainly used in mine, metallurgy, coal washing, FGD, municipal water, etc.

A world-class pump testing center with testing power up to 12,500 kW realizes high precision tests for real pumps which are used for power station, water conservancy and water resources, petrochemical industry, mining and metallurgical industry.



Pump Manufacturing Base for Water Conservancy & Water Resources (Wuxi City, Jiangsu Province)

This base grew out of Wuxi Xi Pump Manufacturing Co., Ltd, a well-known manufacturer for water conservancy.

The base is specialized in production of large and medium-sized pumps for urban water supply and drainage, field irrigation, water conservancy projects and large water diversion projects. The main products cover 8 series with 995 specifications.

With great honor, the model 300HW-8 mixed-flow pump won the first national quality award of Chinese pump industry. As a main supplier, the base provides large pumps for South-to-North Water Diversion Project, a national key project.



Pump Manufacturing Base for Petrochemical Industry (Dalian City, Liaoning Province)

The predecessor of this base is Dalian Huaneng Corrosion-Resistant Pump Works, who's a well-known pump manufacturer in petrochemical industry.

The base is specialized in production of petrochemical pumps for the upstream industry of oil and gas (including exploration, exploitation and storage) and downstream industry of petrochemicals (including crude oil refinery, heavy chemical industry, fine chemistry and coal chemical industry).

The base focuses on design and manufacture of 30 series (OH, BB, VS, etc.) of petrochemical pumps with over 3,000 specifications, which are in accordance with API and ISO standard. The production of large crude oil long distance pipeline pump (BB1 and BB2) and HTHP overloaded pump (BB3 and BB4) is available. LNG cryo-pump is already in development.

The base is Class A supplier of CNPC and qualified sub supplier of Shenhua Group.



Applications

- Water supply systems
- Pressure boosting
- Heating systems for commercial buildings and district heating
- Cooling plants for industrial processing and air-conditioning units
- General transport for industrial processes
- Fire fighting system

Identification Codes

LEP 50-32-130 H(G)/139

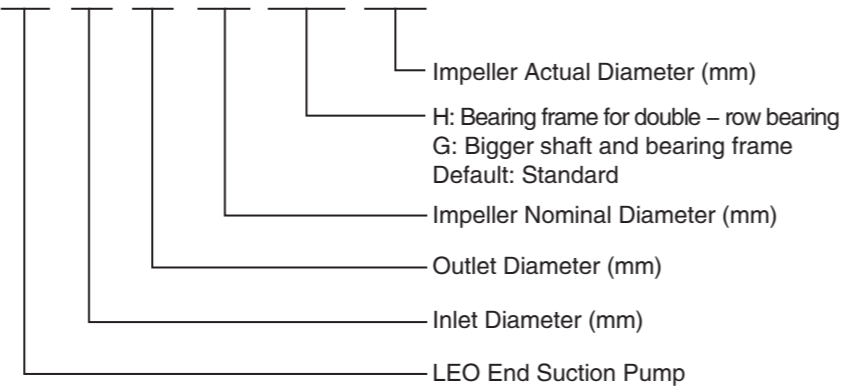

Working Conditions

- Pump design complies to BS EN 733/DIN 24255 standard
- Conveying medium: Low viscosity, non-inflammable and non-explosive liquids not containing solid particles or fibers
- Speed: 1450/2900 rpm at 50 Hz, 1750/3500 rpm at 60 Hz
- Flow range: 0.5 - 440 l/s
- Head range: 2 - 152 m
- Max. liquid temperature: 105°C
- Liquid pH value: 4 - 10
- Max. operation pressure: 10 bar, 16 bar on request

Design & Structure

Design	Performance and dimensions referring to the European standard BS EN733/DIN24255
Structure	Horizontal, Axial End-Suction, Single-Stage, Single-Suction, Volute Casing, Back pull-out
DN(mm)	Inlet: 50-350 Outlet: 32-300
Flange	ISO7005.2 ; DIN2501 PN16 ; GB/T17241.6 PN1.6

Materials Table

No.	Part	Material
1	Pump casing	Ductile Iron 304/316
2	Impeller nut	
3	Wear ring	
4	Impeller	Cut Iron 304/316
5	Casing cover	
6	Shaft spacer	
7	Mechanical seal	
8	Seal cover	
9	Rubber slinger	
10	Bearing frame	
11	Shaft	304/316/1045

No.	Part	Material
12	Bearing	
13	Bearing cover	
14	Support foot	
15	Packing sleeve	Bronze
16	Packing seal cage	
17	Gland packing	
18	Gland cover	
19	Casing gasket	
20	Nut	
21	Nut	
22	Nut	

No.	Part	Material
23	Key	
24	Key	
25	Bolt	
26	Oil nipple	
27	Oil seal	
28	Nut	
29	Washer	
30	Washer	
31	Oil scale	
32	Oil cover	
33	Bearing Cover Gasket	

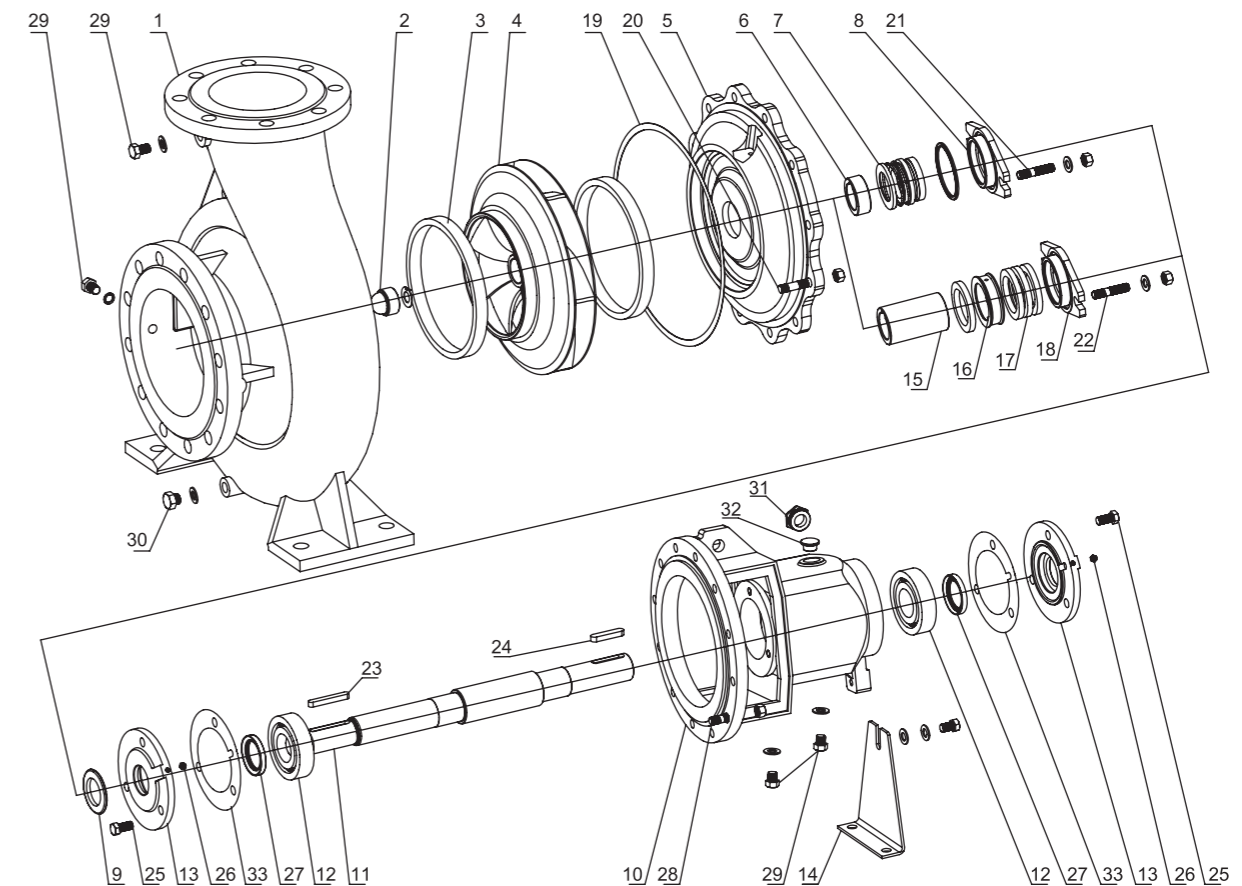

Characteristic Curves

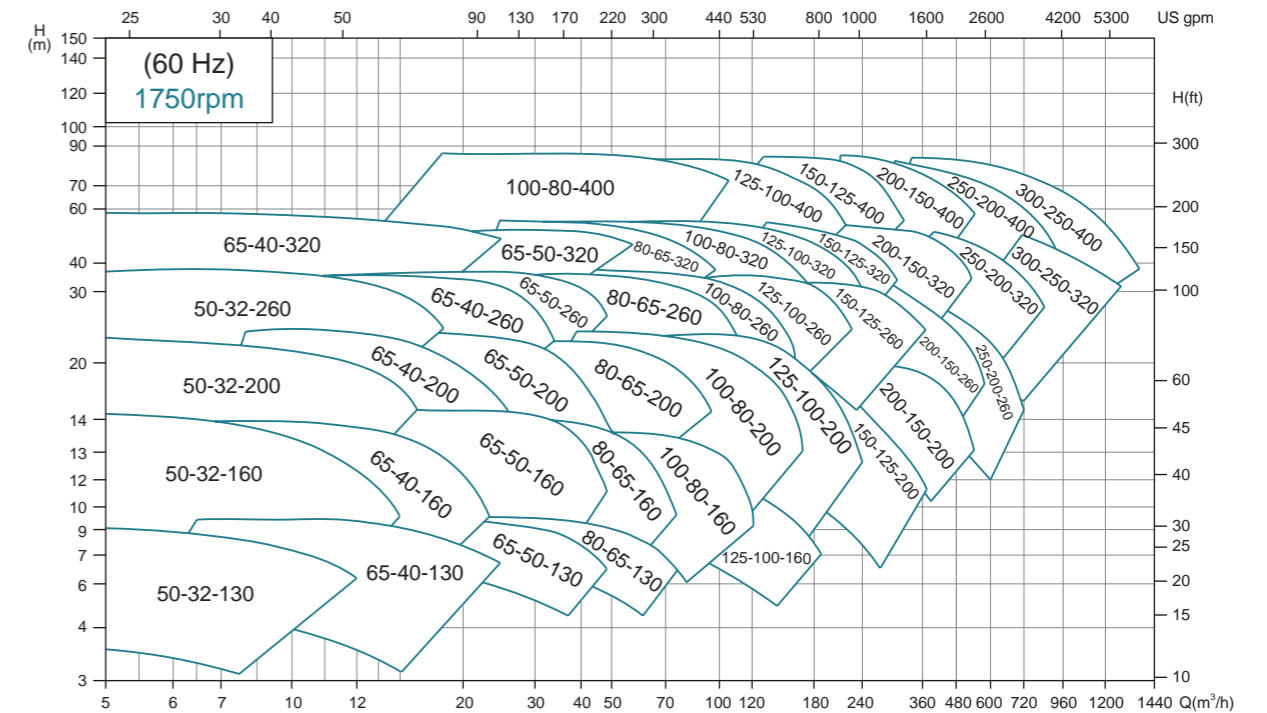
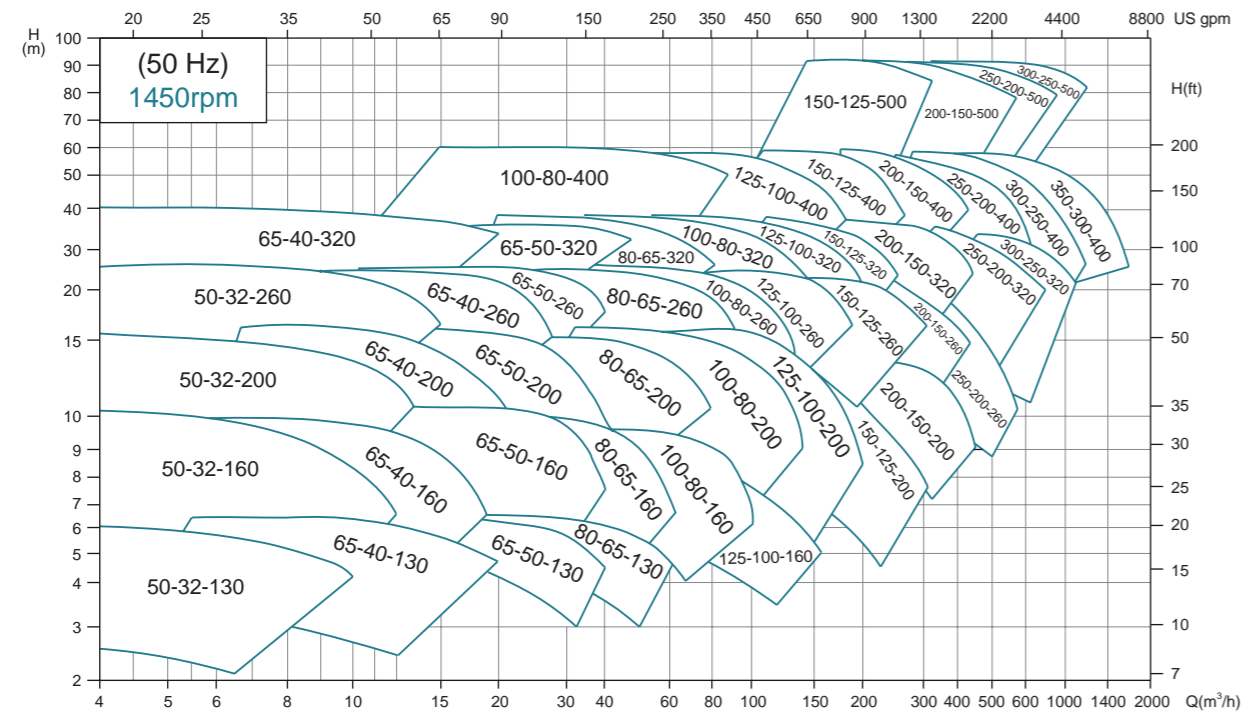
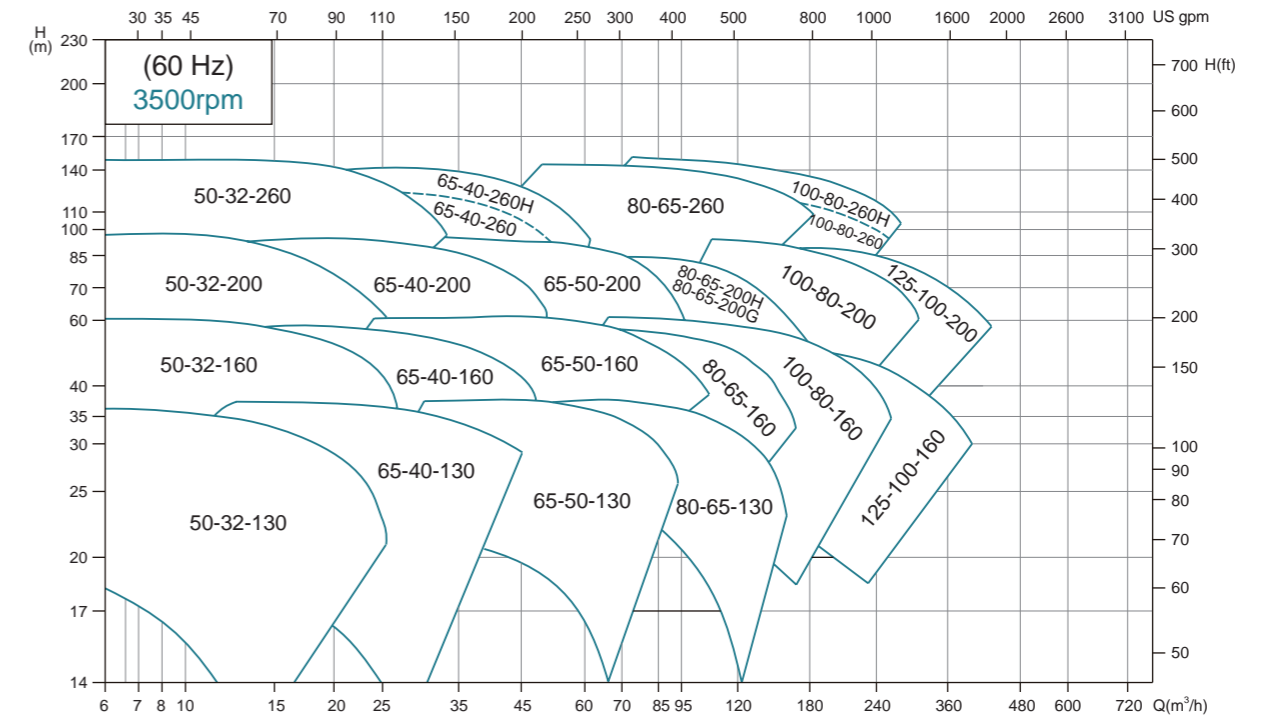
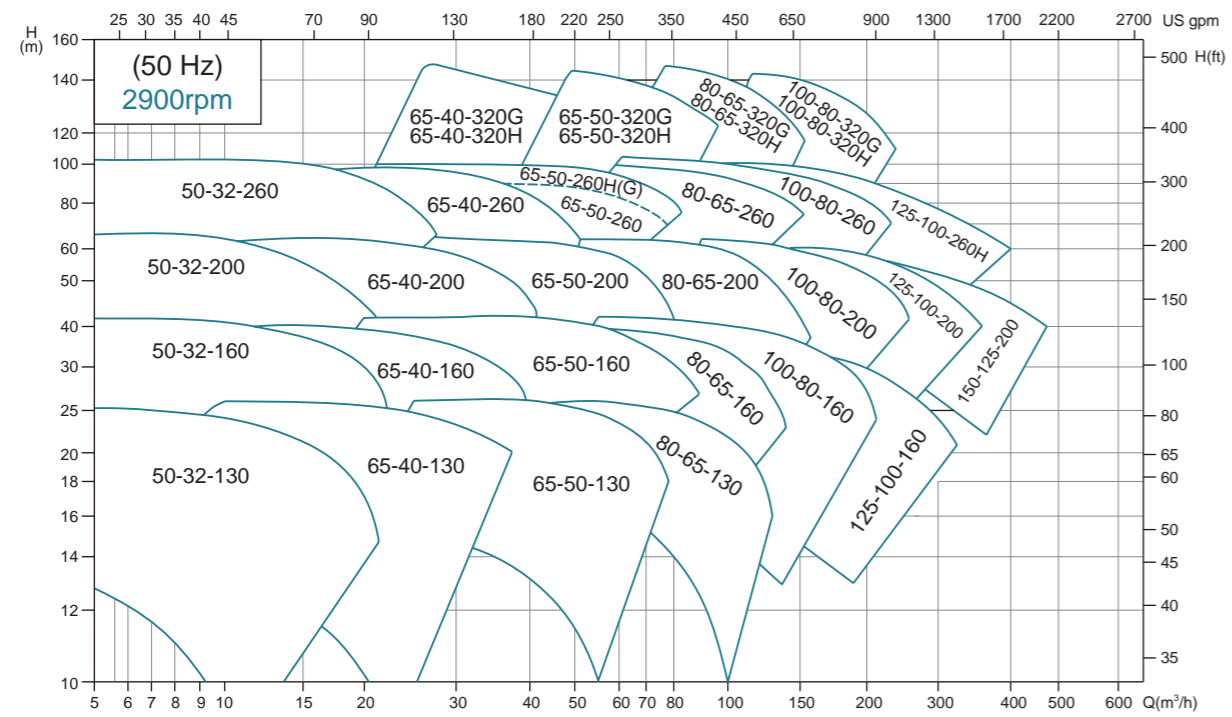

Installation Dimensions

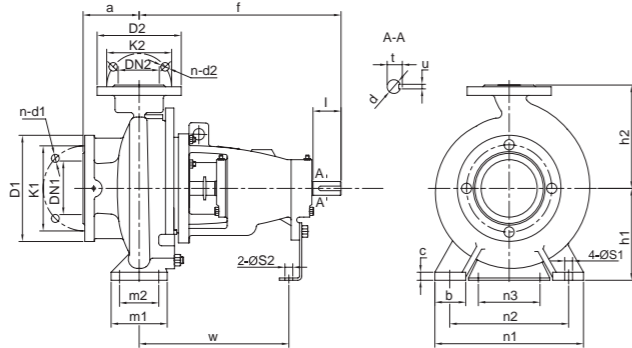

Model	Bearing ID (mm)	DN2	DN1	a	f	h1	h2	b	c	n3	m1	m2	n1	n2	S1	S2	w	d	l	t	u	Weight (Kg)
LEP50-32-130						112	140			100			190	140								29
LEP50-32-160	25	32	50	80	360	132	160	50	14		100	70	240	190	14	14						35
LEP50-32-200						160	180			110	125	95	320	250								47
LEP50-32-260						180	225	65														58
LEP65-40-130						112	140			100			210	160			267	24	50	27	8	31
LEP65-40-160	25	40		80	360	132	160	50		100	100	70	240	190								34
LEP65-40-200						160	180			110			265	212								45
LEP65-40-260(H)						180	225						320	250								61
LEP65-40-320	35	65		125	470	200	250	65	14	110	125	95	345	280			342	32	80	35	10	94
LEP65-40-320(H)						200	250										367	42	110	45	12	107
LEP65-40-320G	45					526	200	250														105
LEP65-50-130						132	160			100			240	190								35
LEP65-50-160	25	50		100	360	160	180	50			100	70	265	212	14		267	24	50	27	8	39
LEP65-50-200						160	200						265	212								49
LEP65-50-260(H)						180	225				125	95	320	250								68
LEP65-50-260G	35					180	225	65					320	250			344	32	80	35	10	65
LEP65-50-320(H)						225	280		18				345	280			342	32	80	35	10	113
LEP65-50-320G	45	50	65	125	526	225	280		18		125	95					367	42	110	45	12	105
LEP80-65-130						160	180						280	212								41
LEP80-65-160	25	65		100	360	160	200	65	14		125	95	320	250			267	24	50	27	8	47
LEP80-65-200(H)						180	225						320	250								55
LEP80-65-200G						465	180	225									339					60
LEP80-65-260	35	80		125	470	200	250		15				360	280			342	32	80	35	10	87
LEP80-65-320(H)						225	280	80	18		160	120	400	315	18							110
LEP80-65-320G	45					526	225	280	18				400	315			367	42	110	45	12	120
LEP100-80-160	25	80		125	530	180	225	65	14		125	95	320	250	14		267	24	50	27	8	53
LEP100-80-200						180	250						345	280								76
LEP100-80-260(H)	35	100		150	470	200	280		15				400	315			342	32	80	35	10	95
LEP100-80-320(H)						250	315	80	16				400	315								118
LEP100-80-320G	45					526	250	315	16				440	340	18		367	42	110	45	12	130
LEP100-80-400						530	280	355	83	18			440	340			370	42	110	45	12	160
LEP125-100-160	35	100		125	530	200	250	80	15	110	160	120	400	315	18		342	32	80	35	10	87
LEP125-100-200						200	280						360	280								84
LEP125-100-260(H)	35	150		175	470	225	280	80	16				400	315			342	32	80	35	10	102
LEP125-100-320						250	315						400	315								118
LEP125-100-400	45					530	280	355	100	20			450	350	23		370	42	110	45	12	176
LEP150-125-200						200	280				200	150	500	400	23							112
LEP150-125-260	35	150		175	470	250	315	80	16		160	120	400	315	18		342	32	80	35	10	117
LEP150-125-320						280	355						500	400								155
LEP150-125-400	45	125	150	175	530	315	400		18				500	400			370	42	110	45	12	178
LEP150-125-500	55					670	355	450	25				550	450			500	48	110	51	14	300
LEP200-150-200	35	150		175	555	280	400						400	315			342	32	80	35	10	132
LEP200-150-260						250	355				200	150	450	350	23							163
LEP200-150-320	45	200		225	530	280	400		18				450	350			370	42		45	12	170
LEP200-150-400						315	450						550	450								207
LEP200-150-500	55					670	375	500	22				550	450			500	48	110	51	14	330
LEP250-200-260	45	200		225	555	315	450						500	400			392	42		45	12	219
LEP250-200-320						315	480		20		220	170	600	480	28							286
LEP250-200-400	55					335	480	120	20		250						505	48		51	14	328
LEP250-200-500	65	200	250	200	720	425	560	100	22	140	200	150	660	560	23	19	515	60	140	64	18	450
LEP300-250-320						691	355	520					525	510	28	14	525	48	110	51	14	366
LEP300-250-400	55	250	300	220	682	400	560		26	110	250	200	660	510	28	14	516	48	110	51	14	396
LEP300-250-500	65	250	300	200	720	450	670	120	32	140	240	190	750	650	23	19	515	60	140	64	18	550
LEP350-300-400	65	300	350	300	720	425	670	120	30	140	250	190	760	660	30	19	515	60	140	64	18	550

(ISO7005.2 DIN2501 PN16 GB/T17241.6 PN1.6)

DN1/DN2	32	40	50	65	80	100	125	150	200	250	300	350	400
D1/D2	140	150	165	185	200	220	250	285	340	405	460	520	580
K1/K2	100	110	125	145	160	180	210	240	295	355	410	470	525
n-d1/n-d2	4-φ18	4-φ18	4-φ18	4-φ18	8-φ18	8-φ18	8-φ18	8-φ22	12-φ22	12-φ26	12-φ26	16-φ26	16-φ30

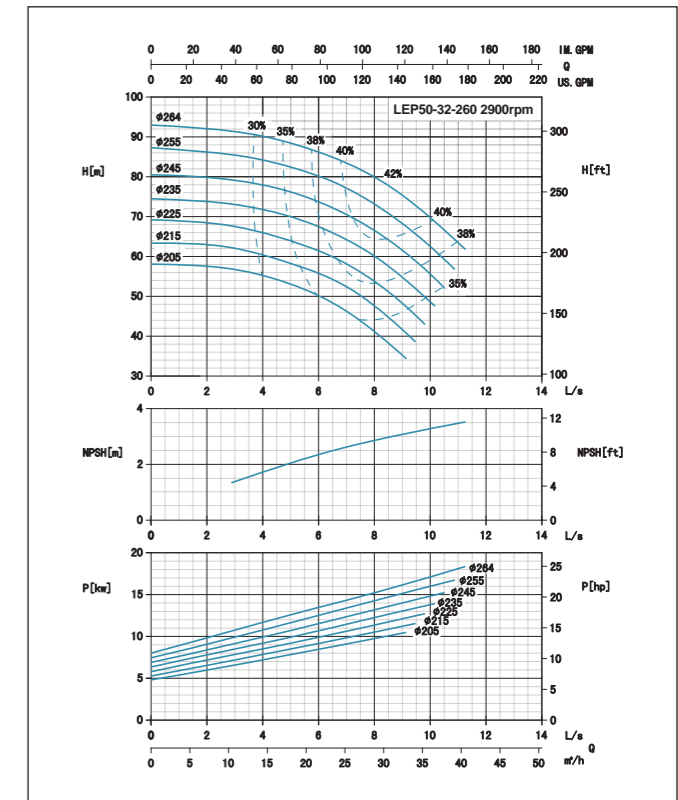
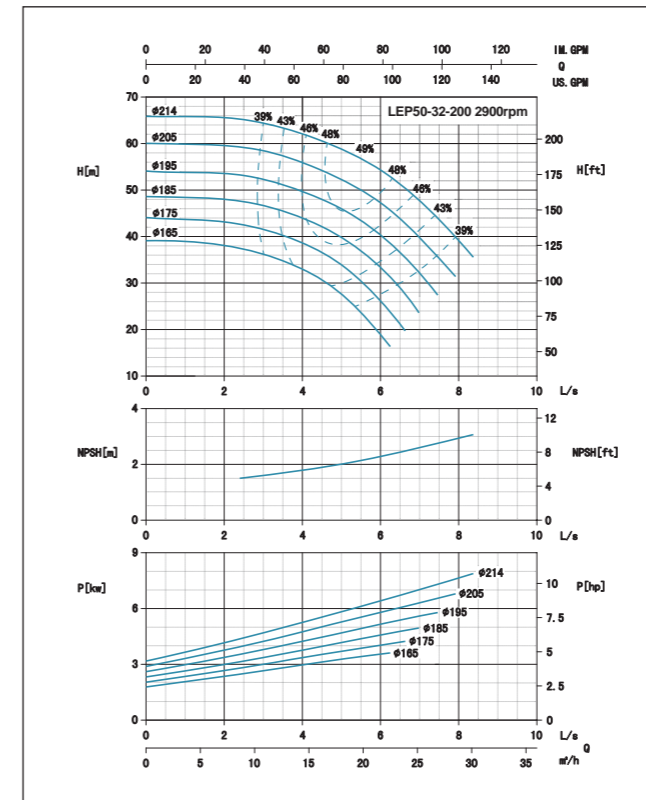
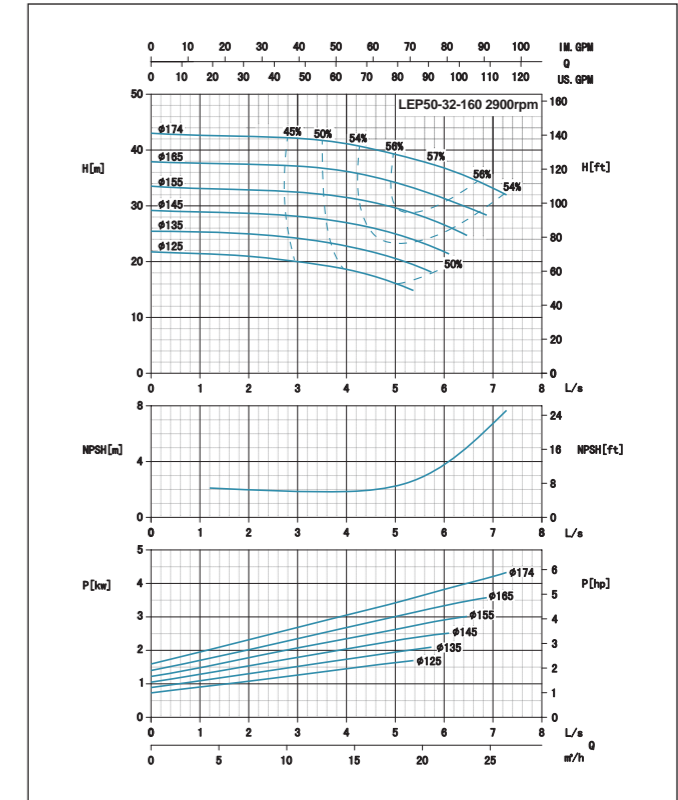
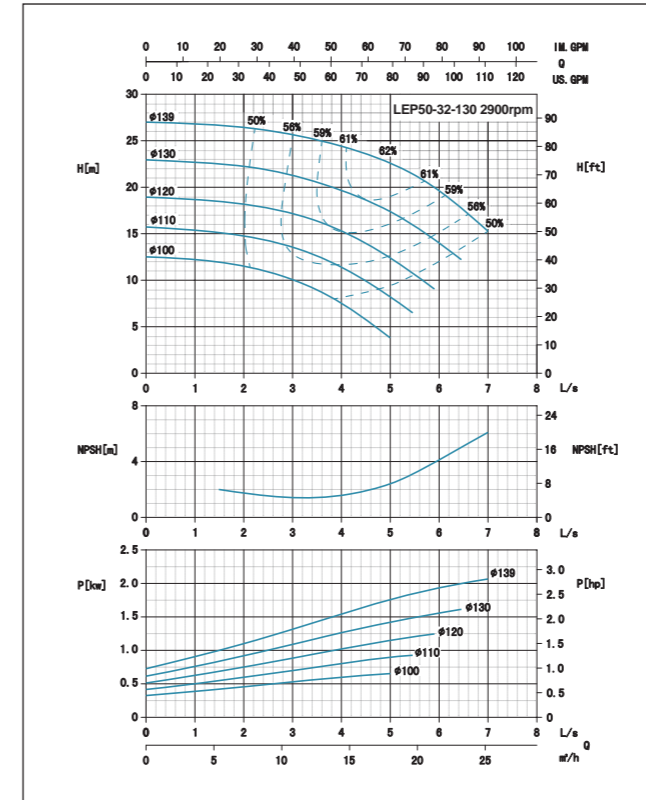

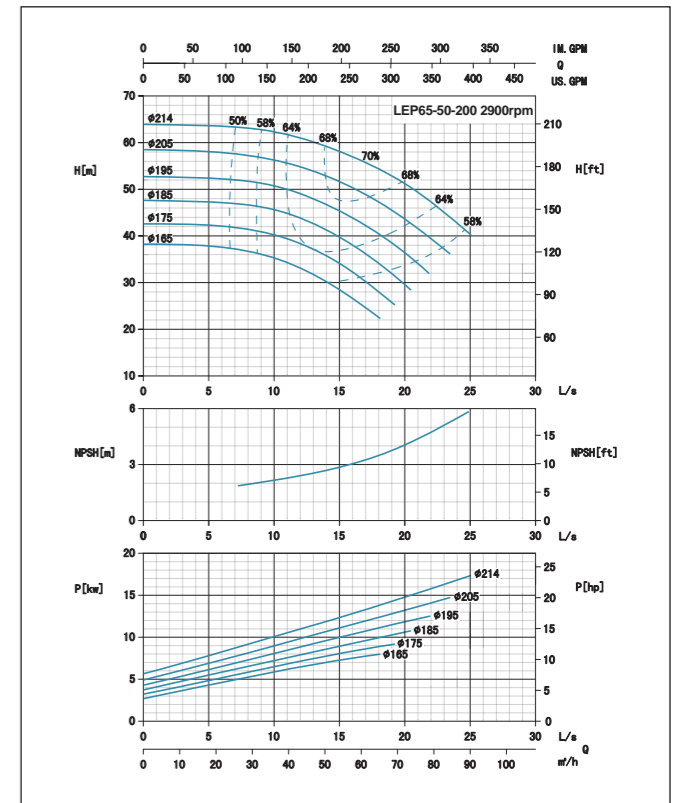
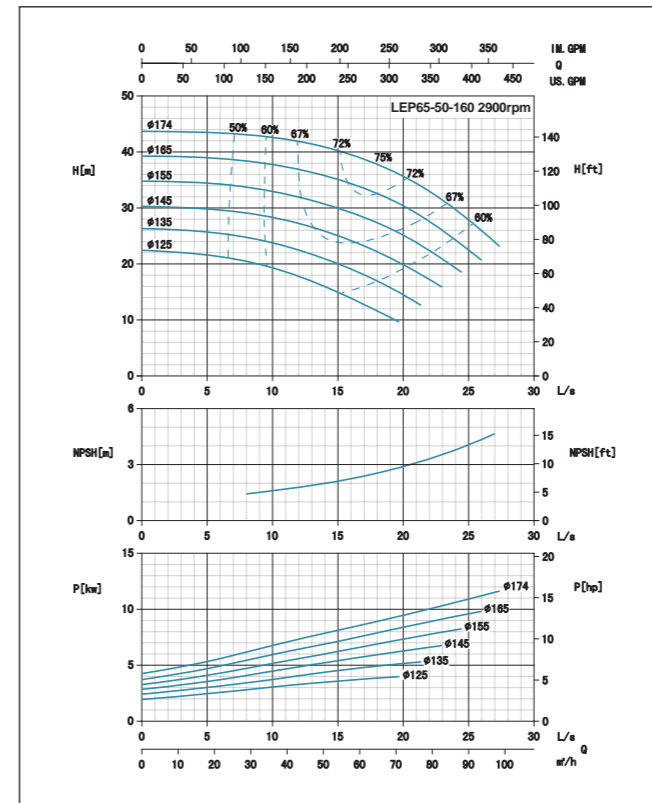
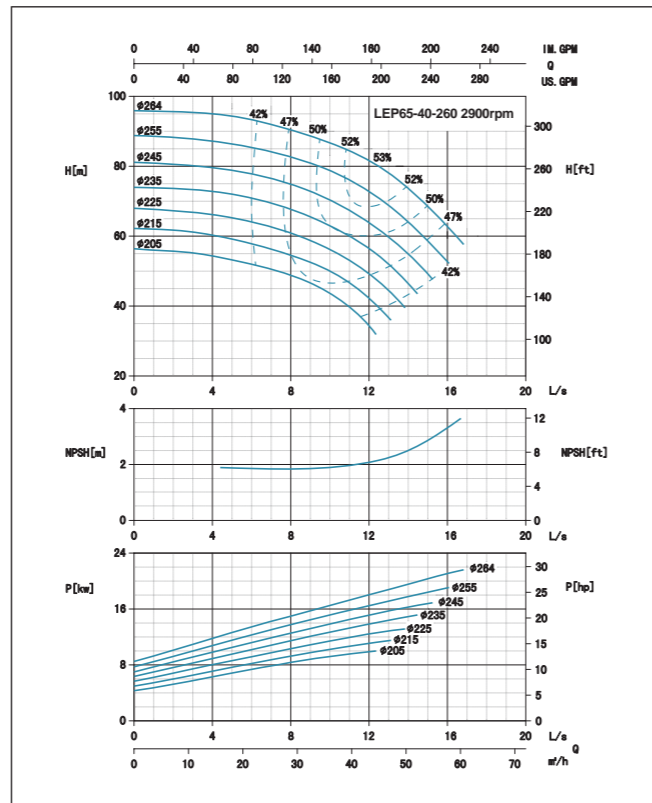
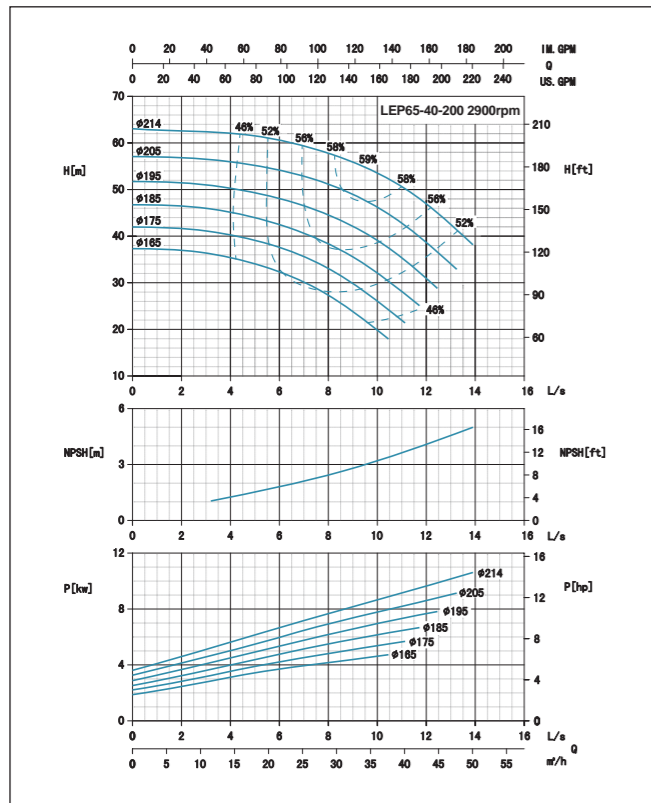
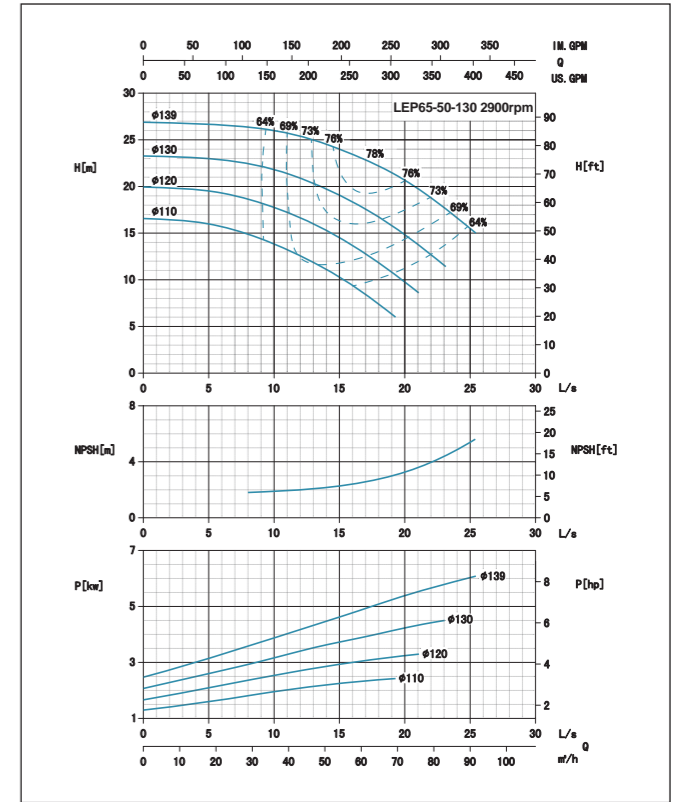
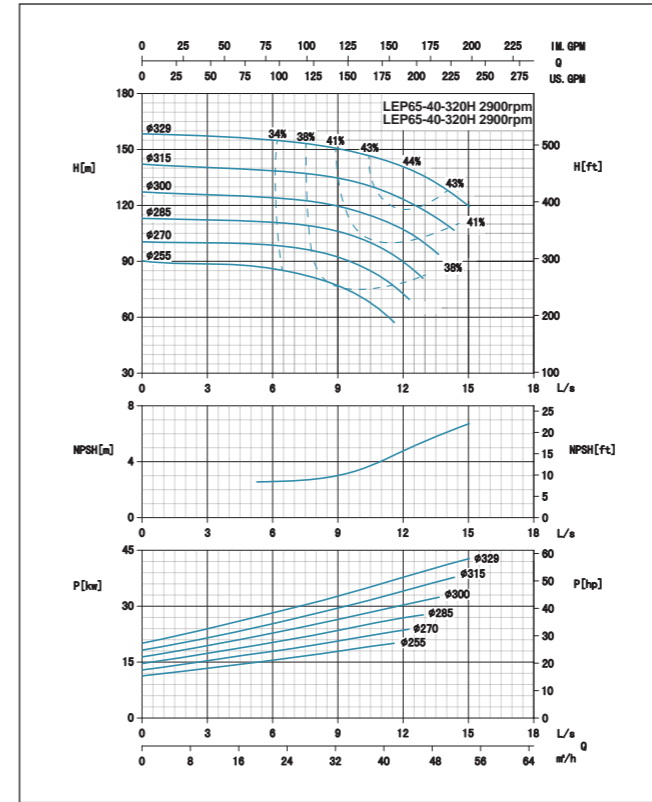
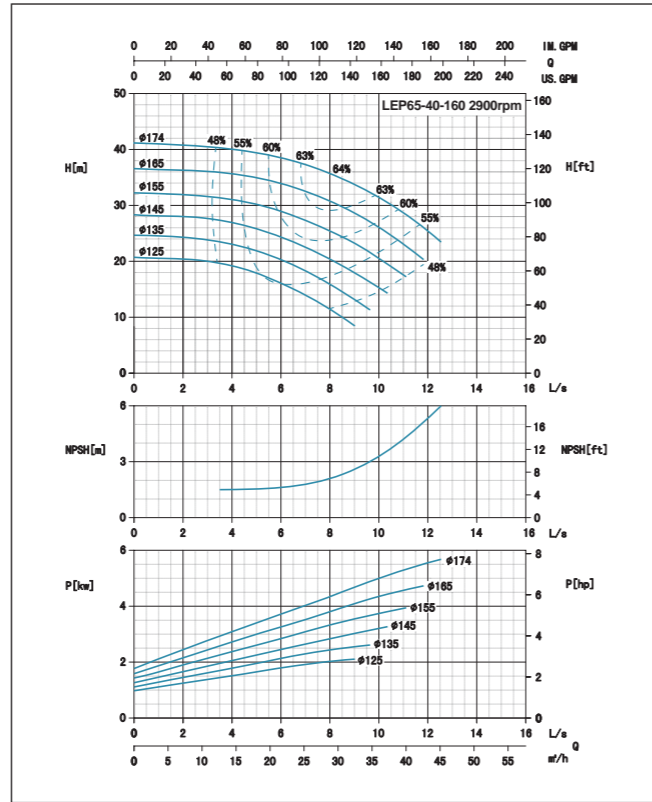
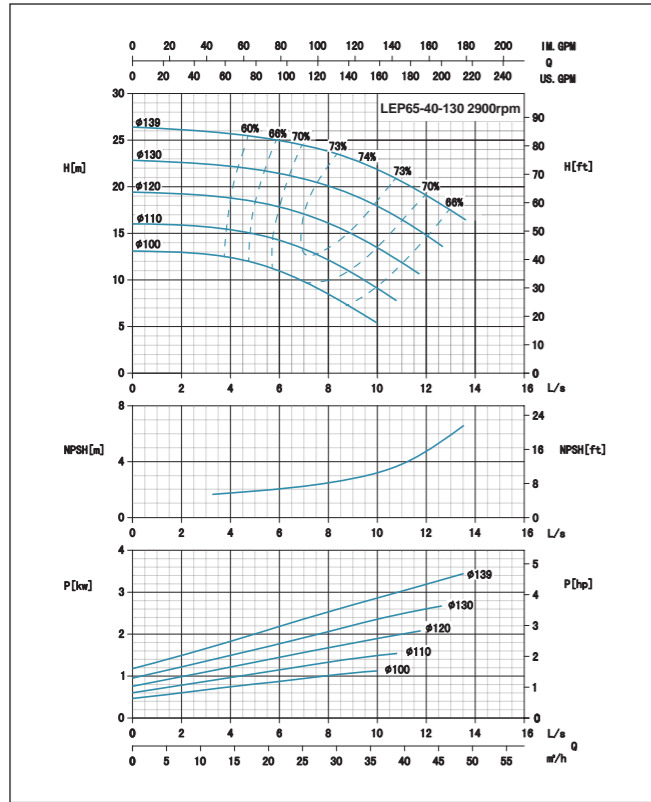

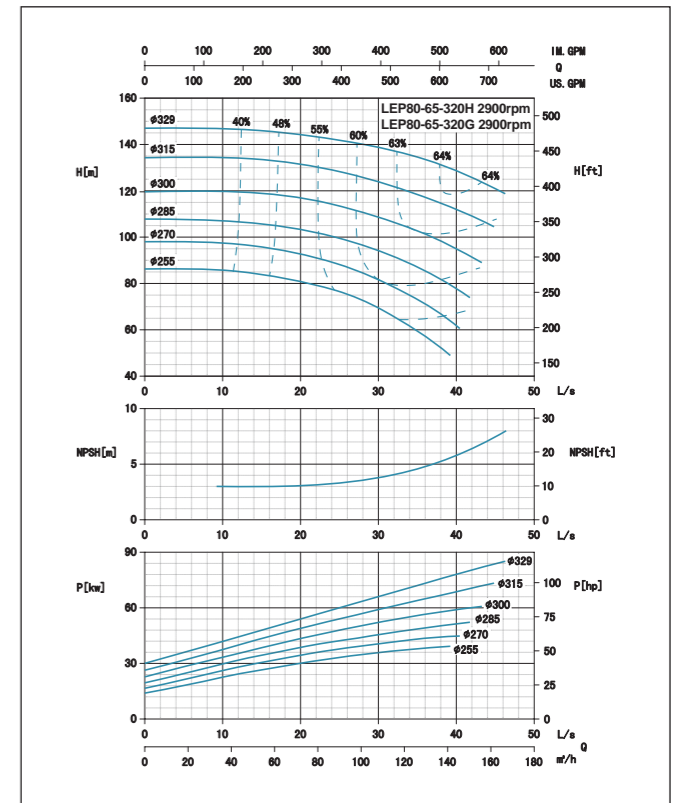
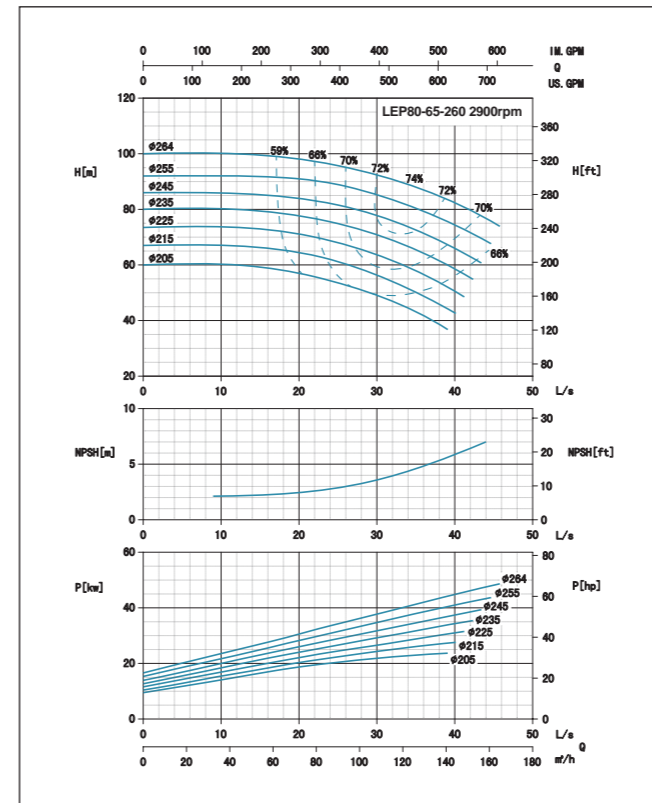
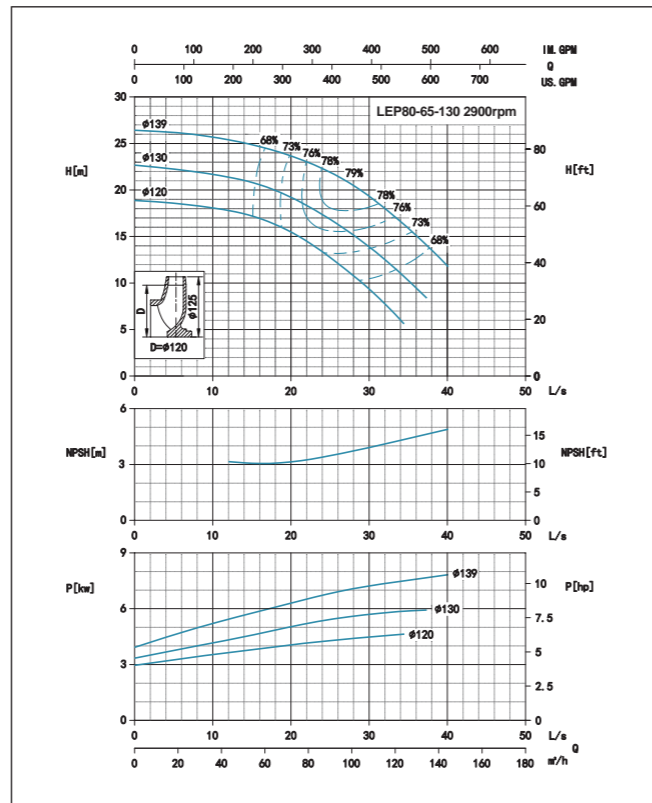
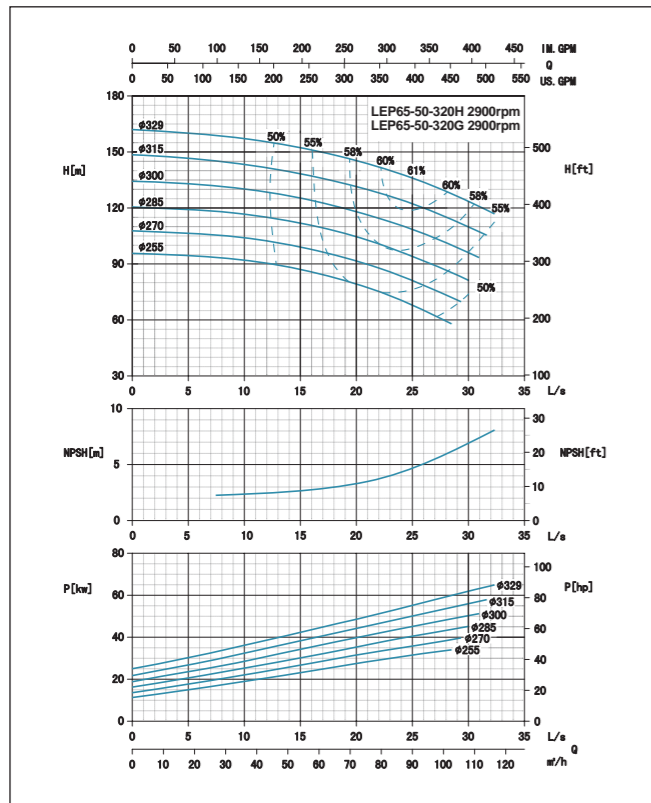
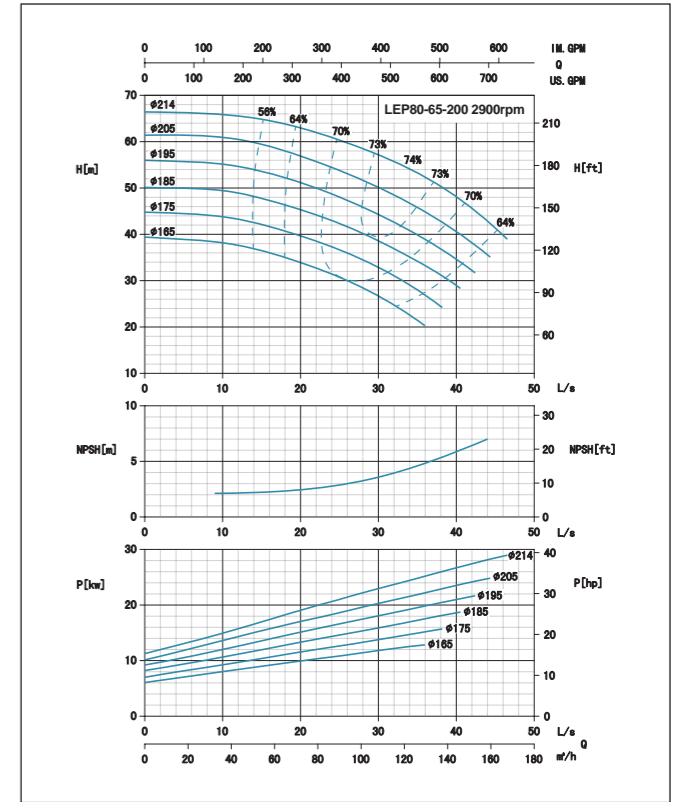
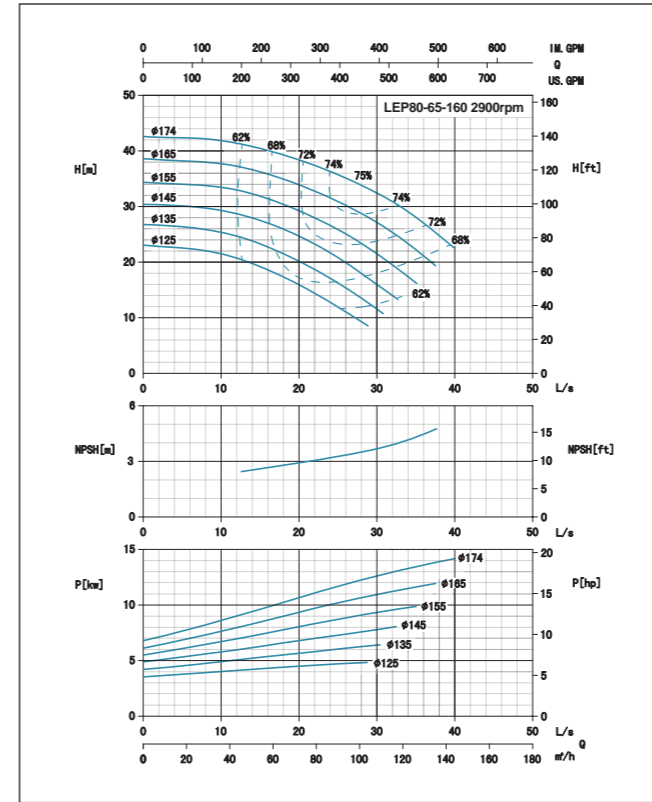
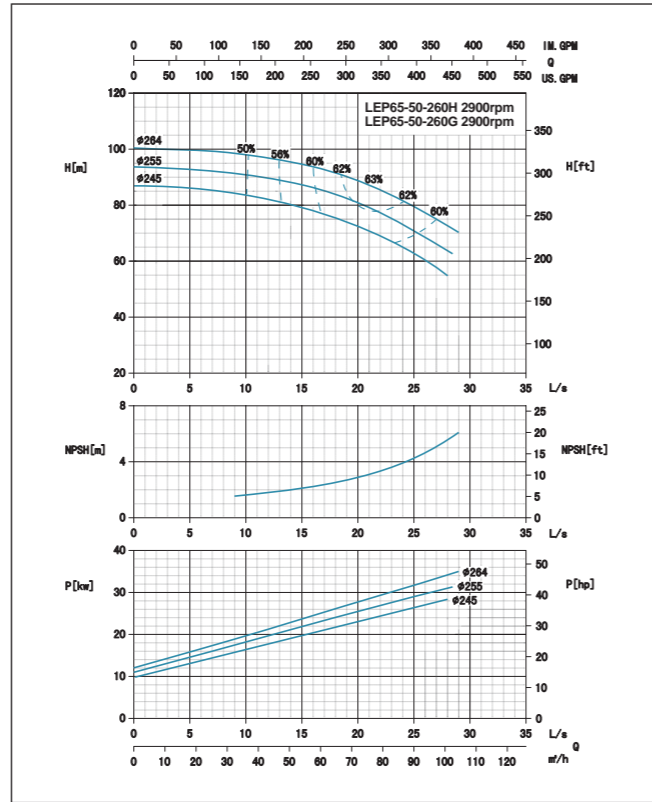
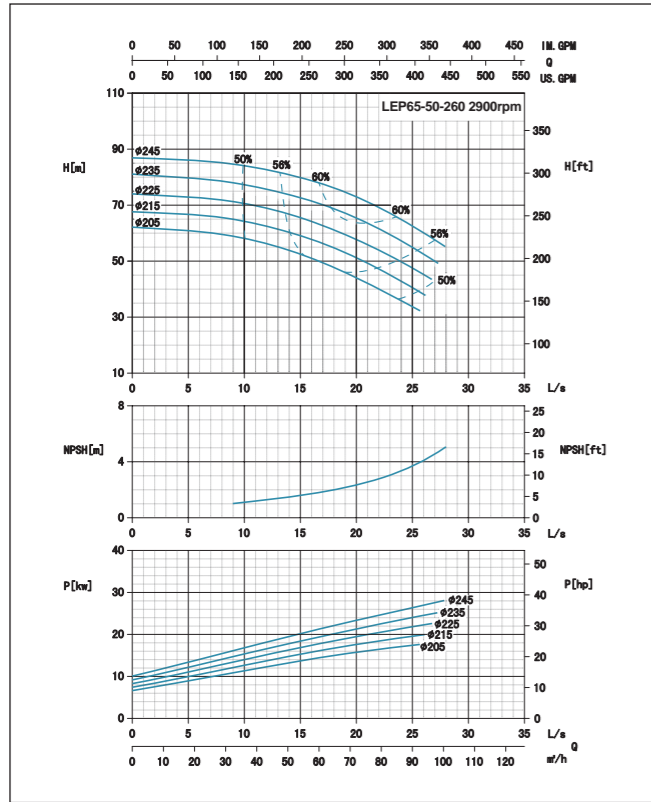

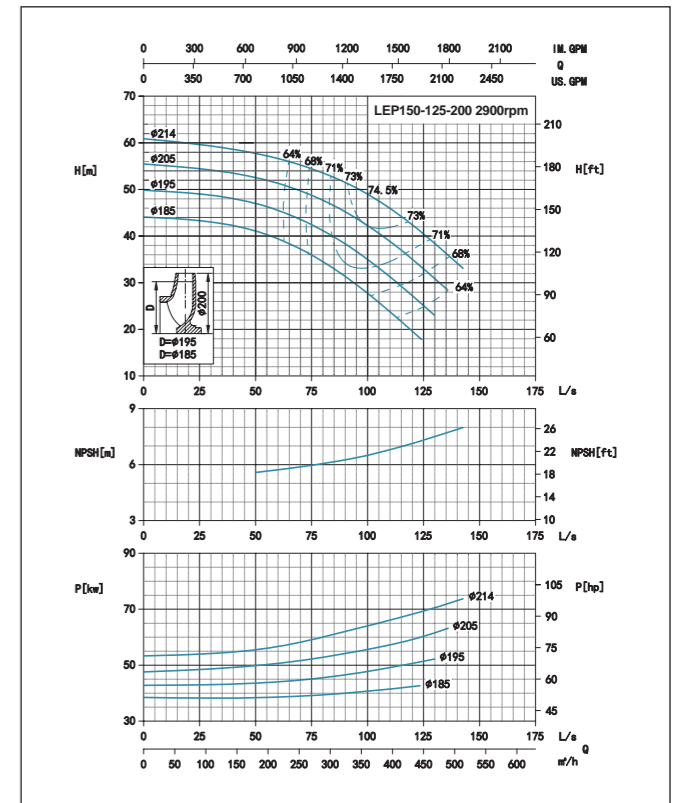
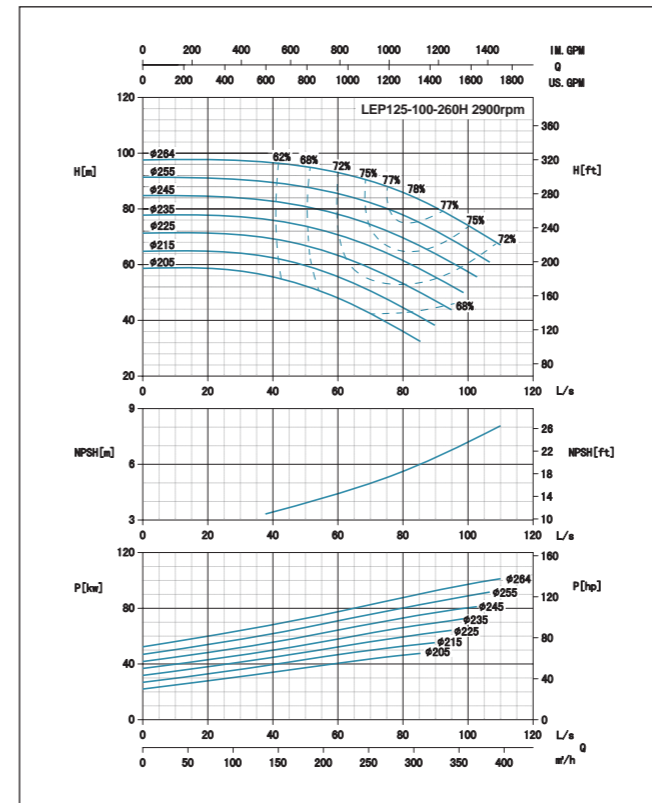
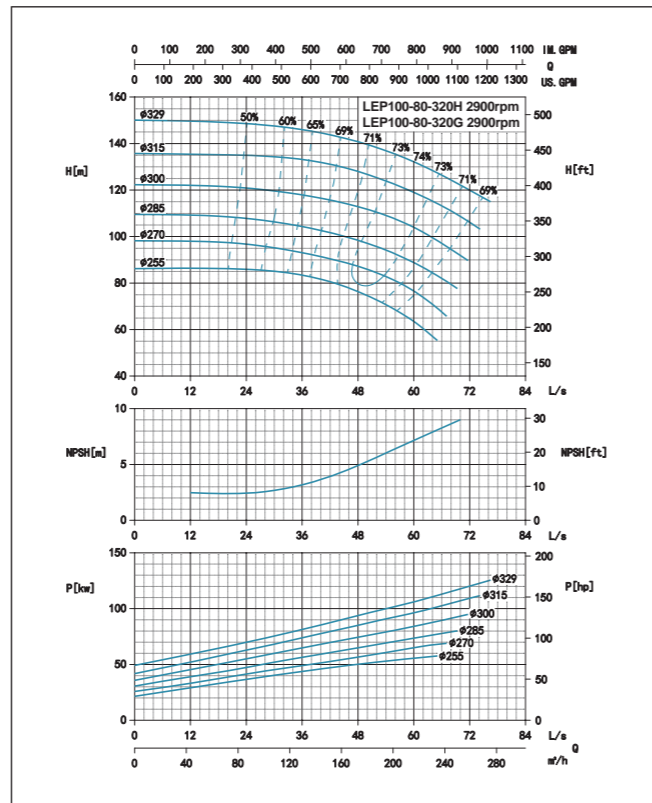
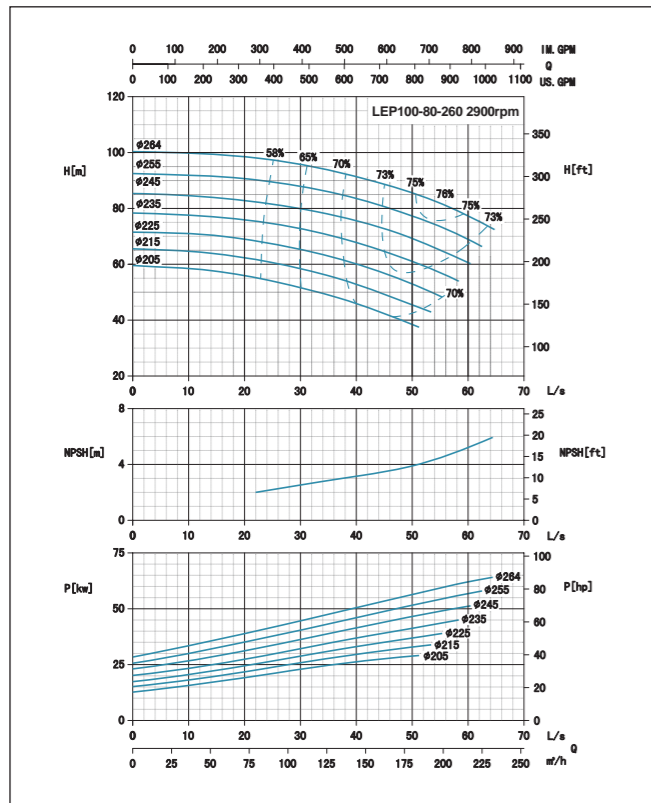
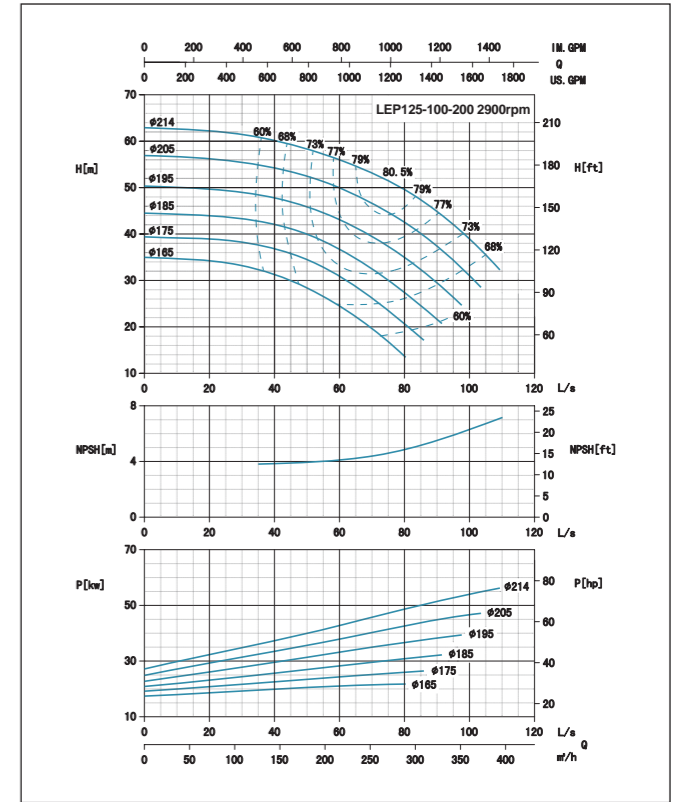
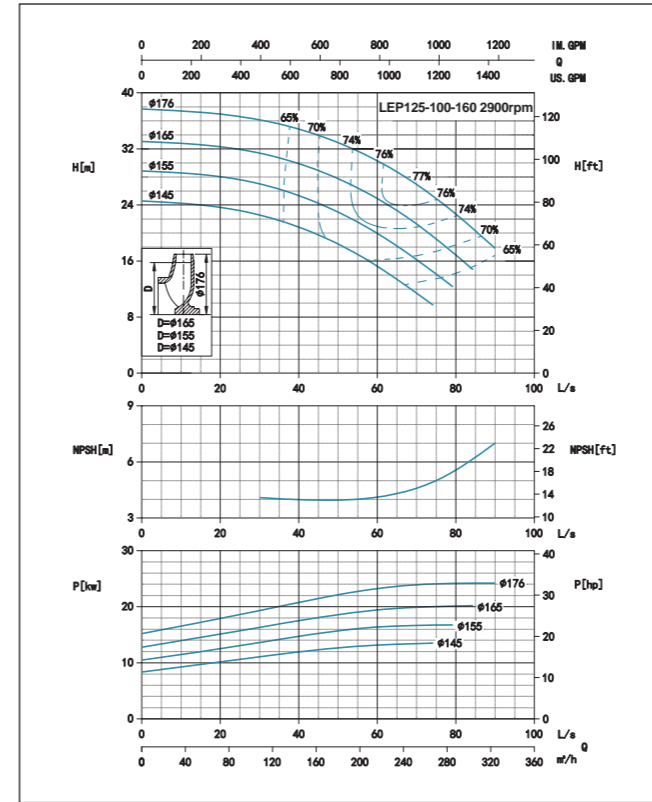
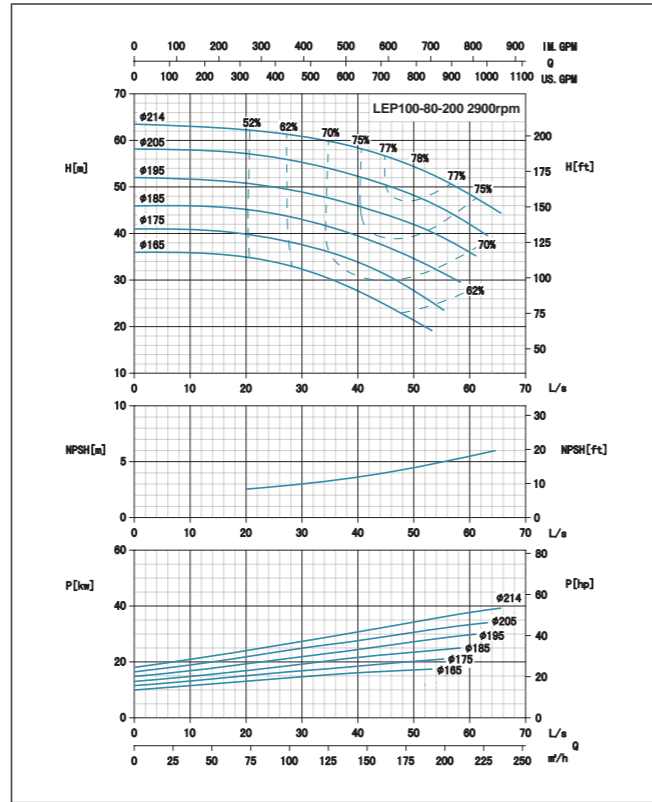
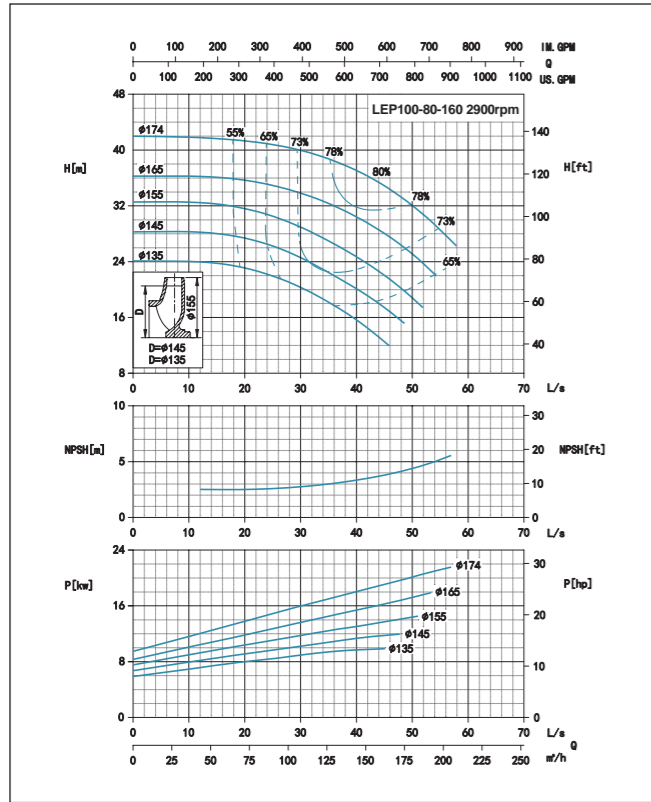

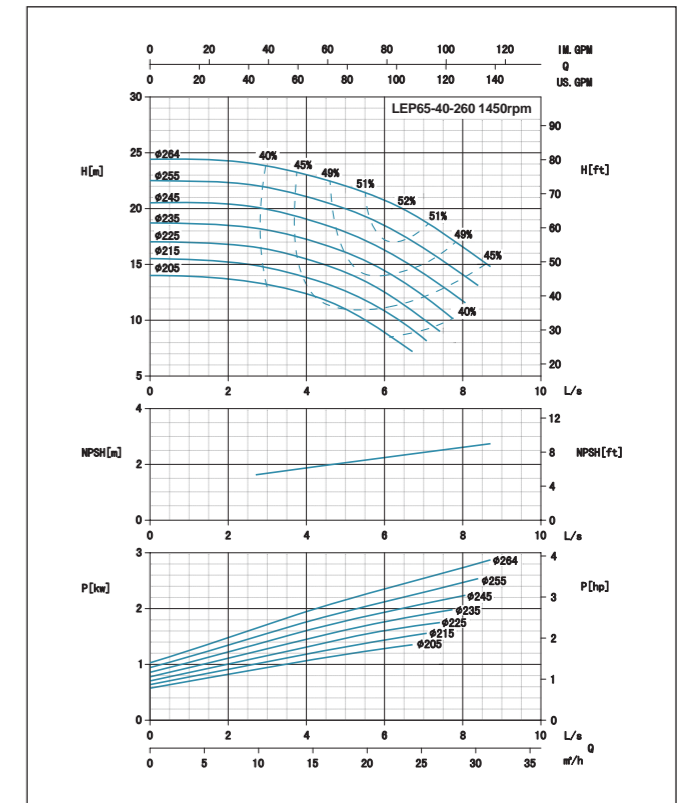
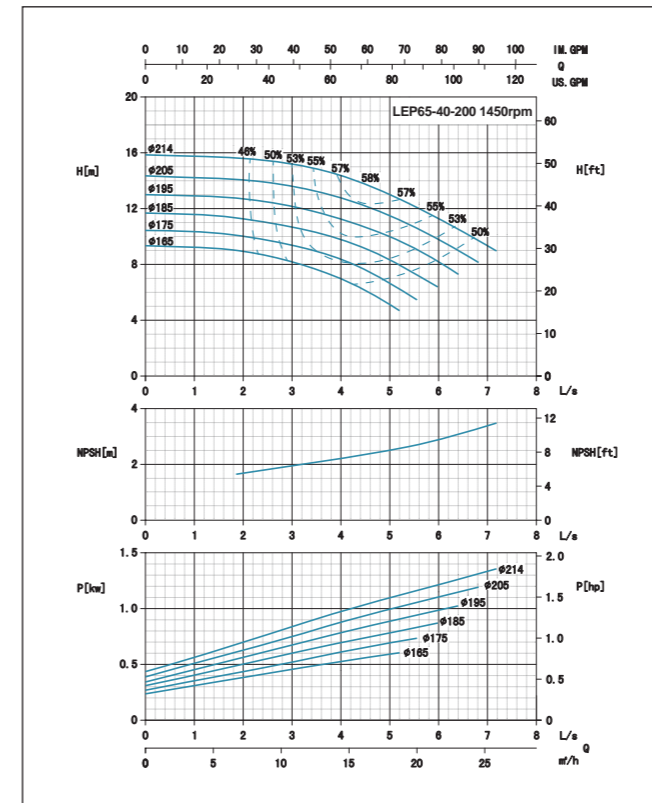
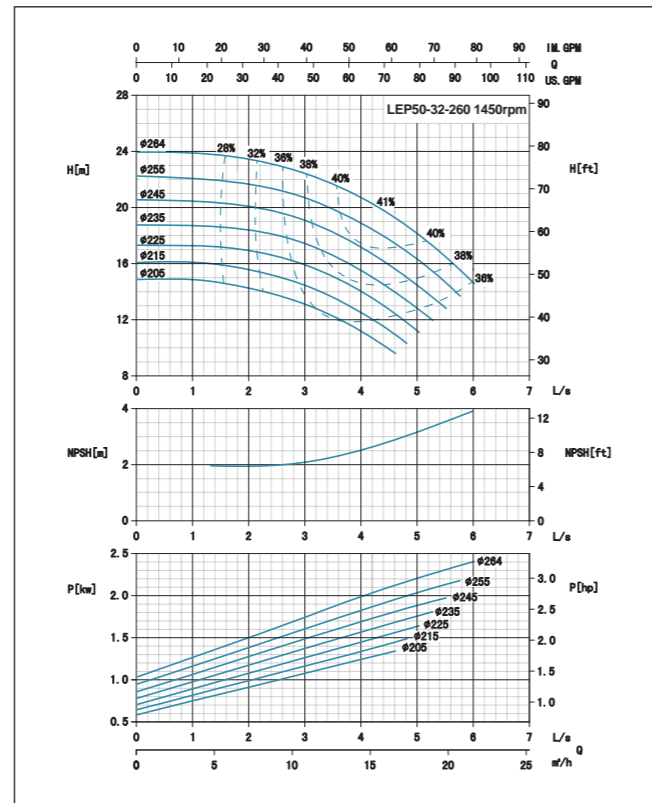
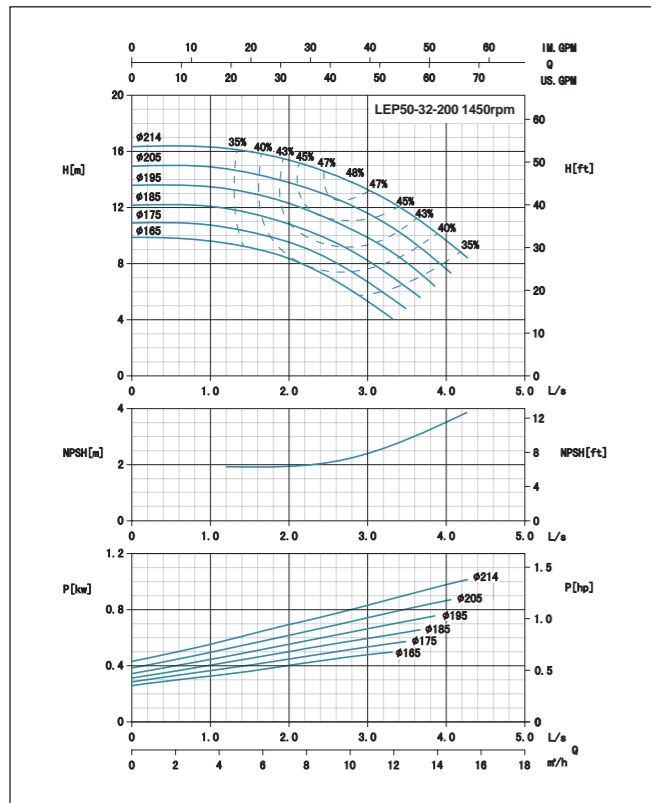
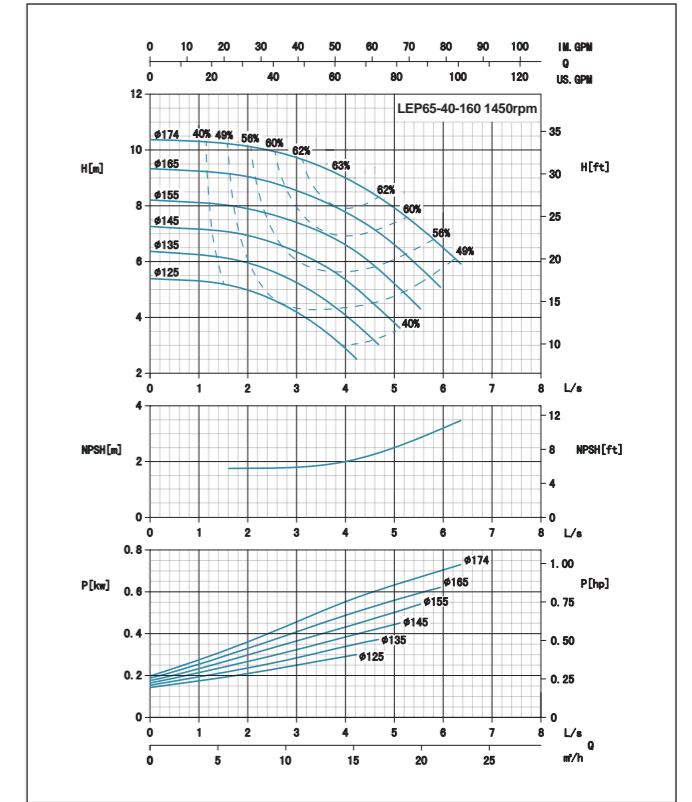
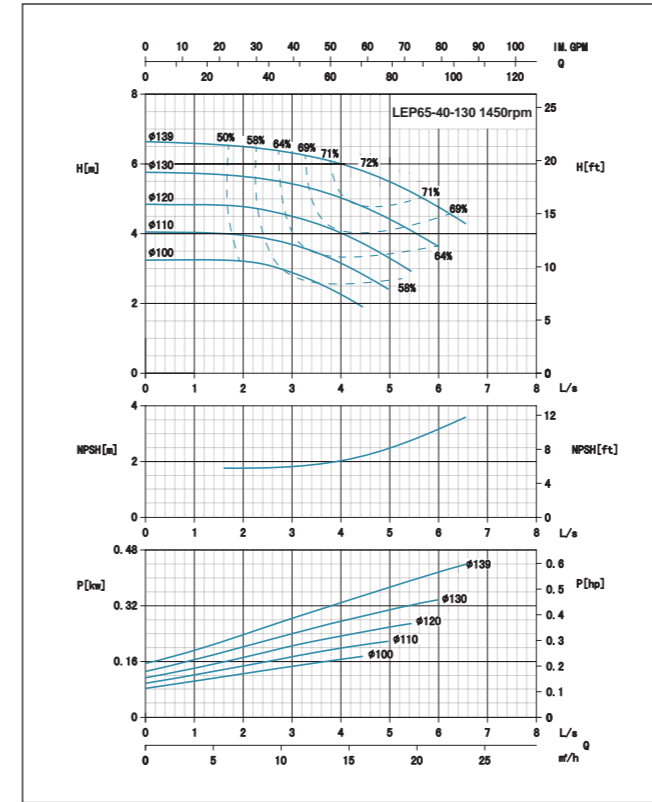
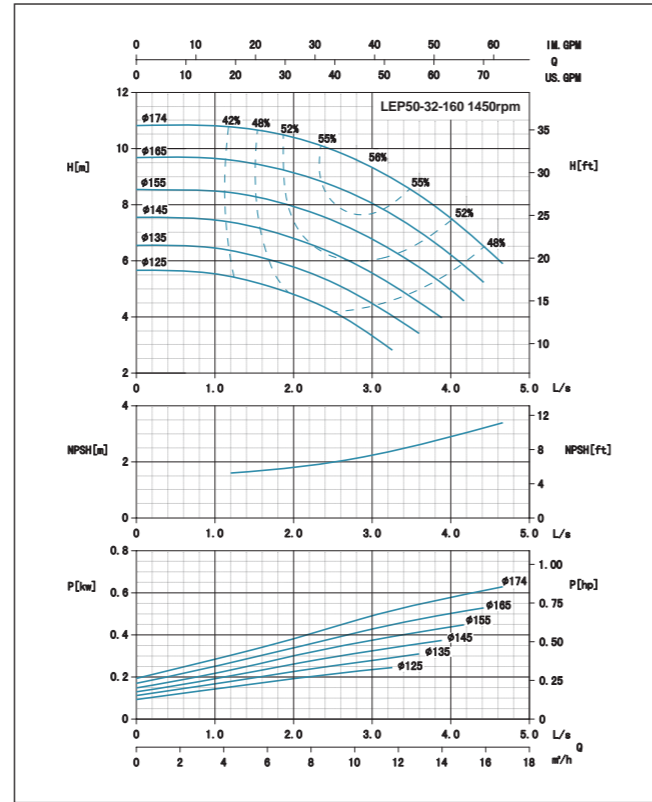
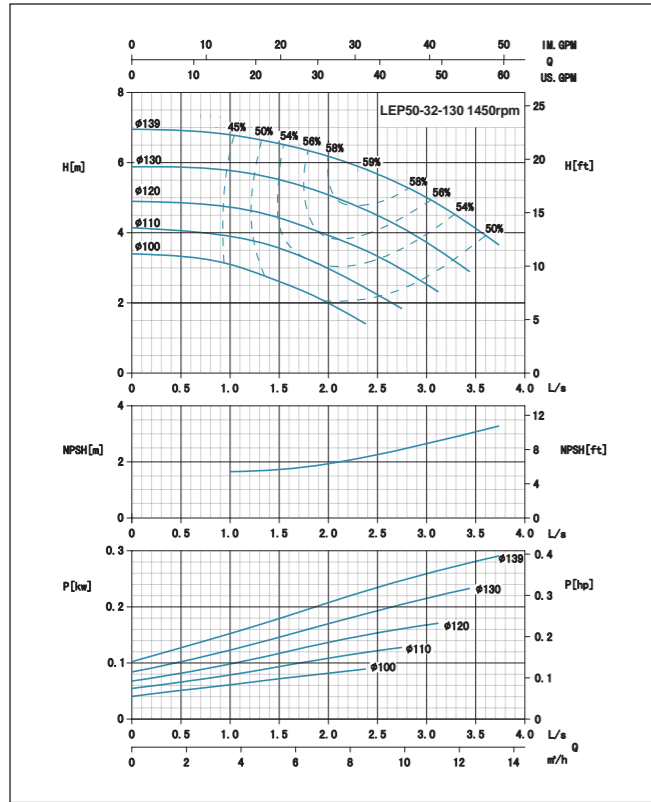

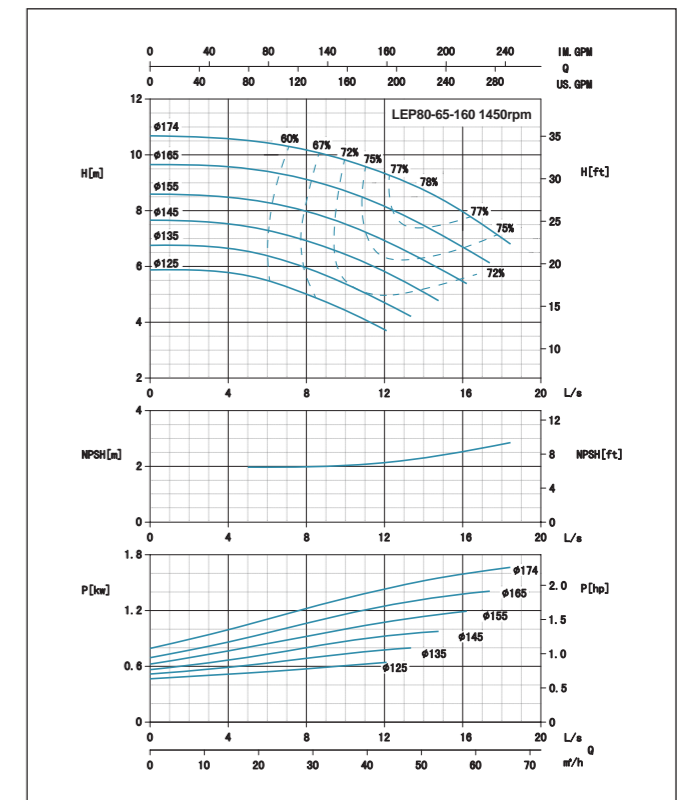
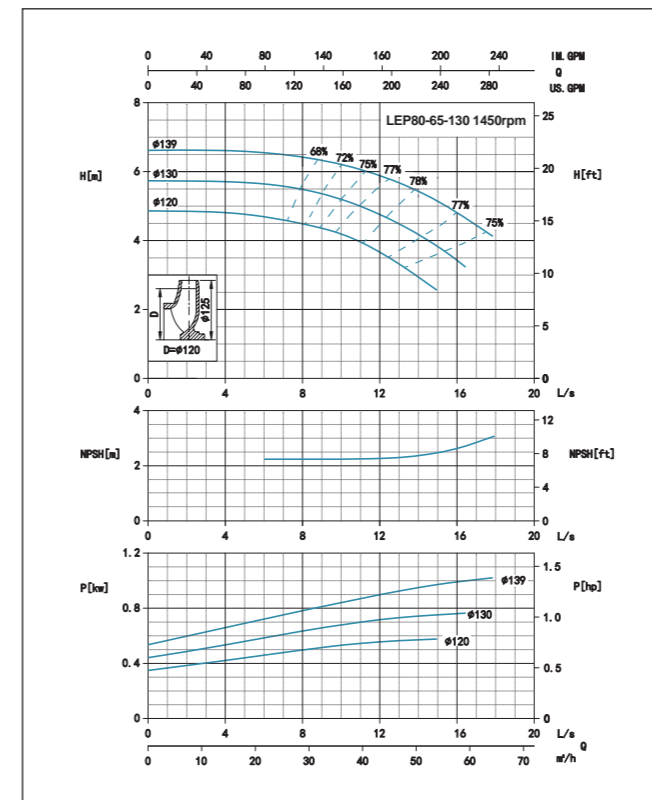
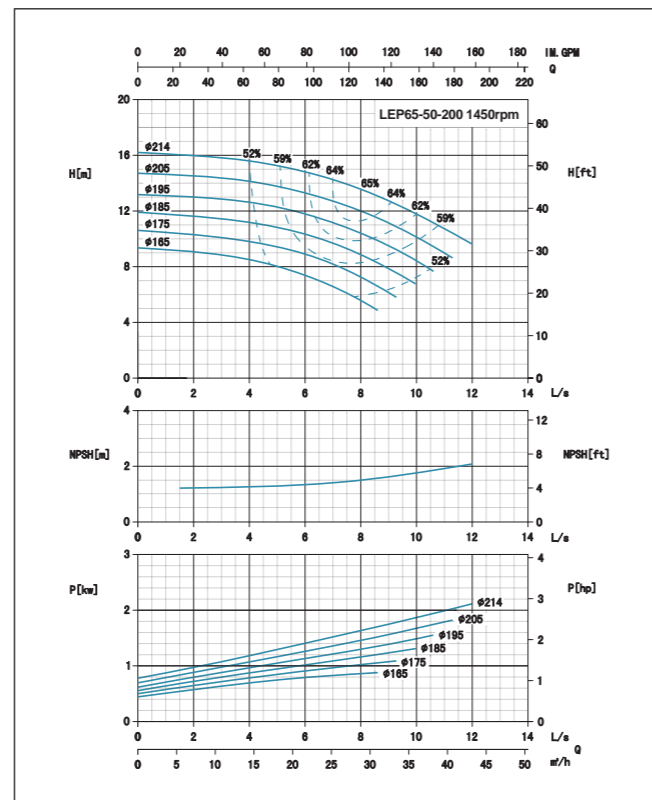
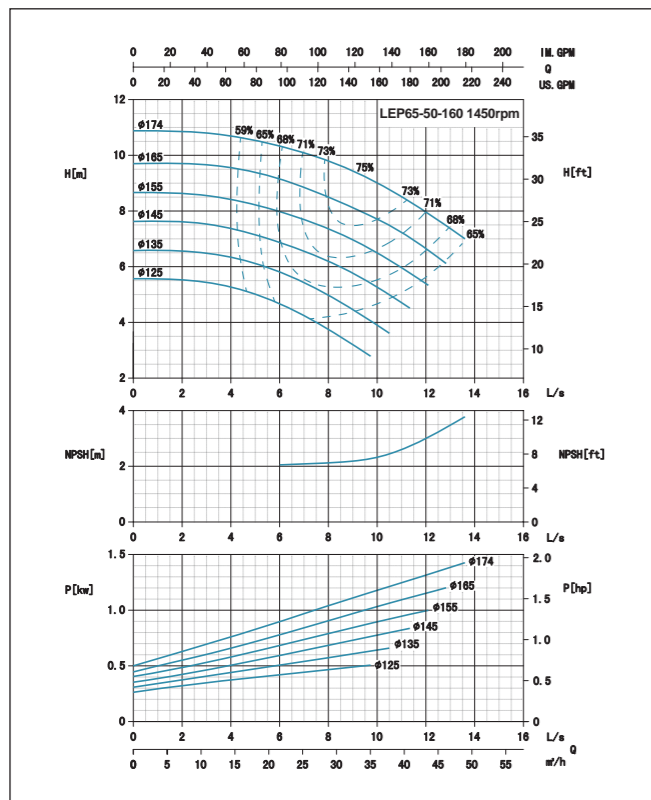
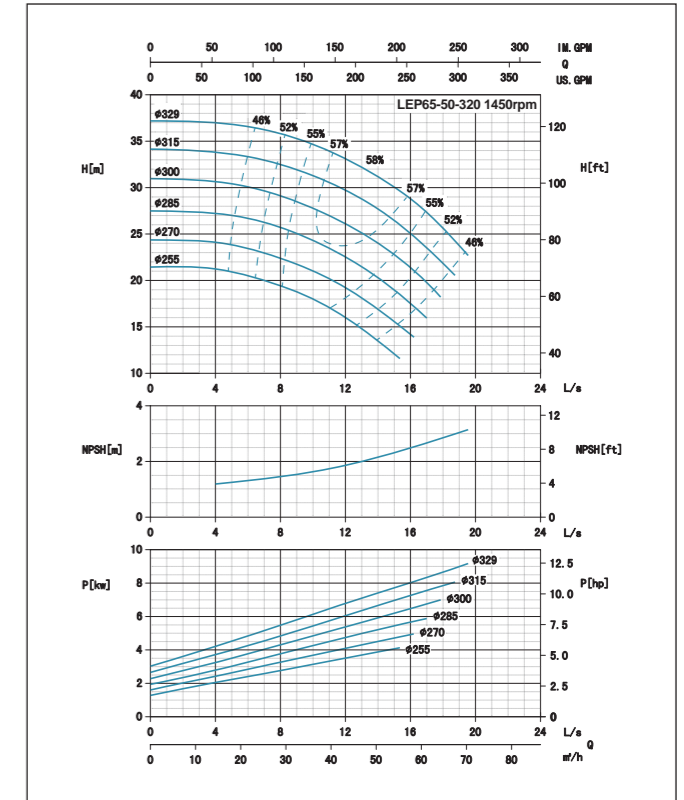
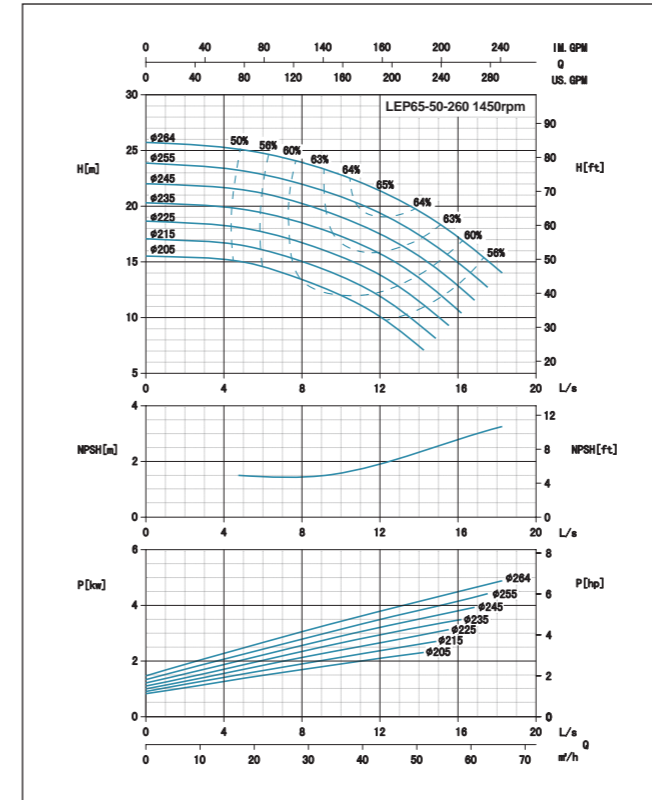
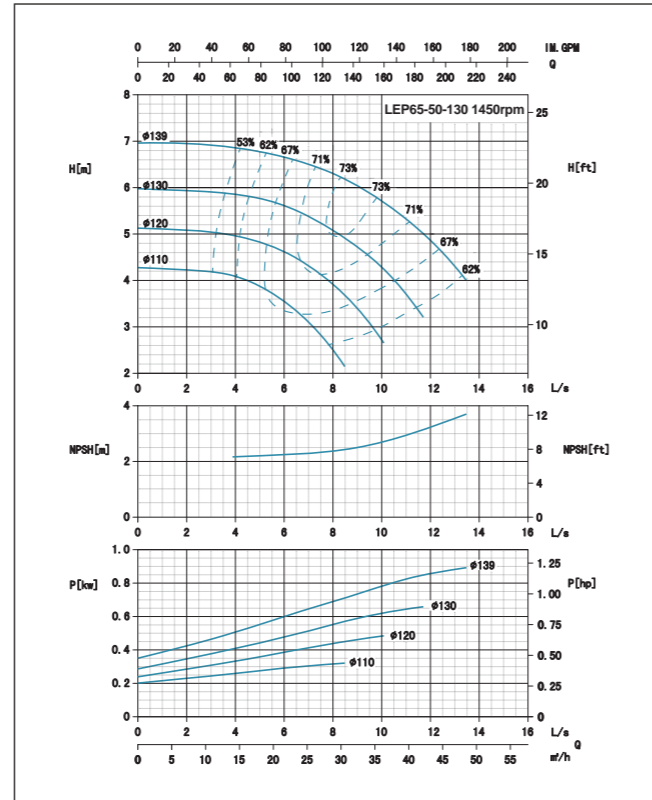
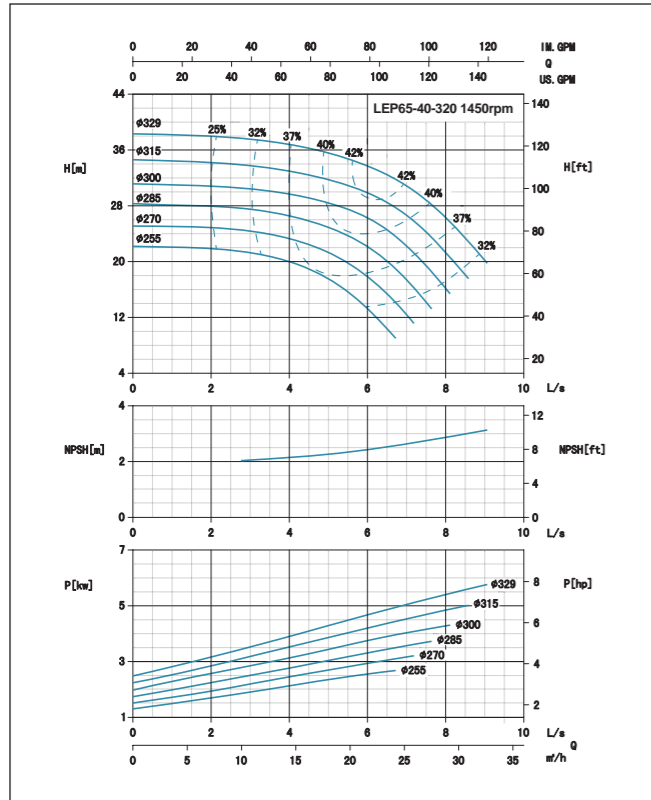

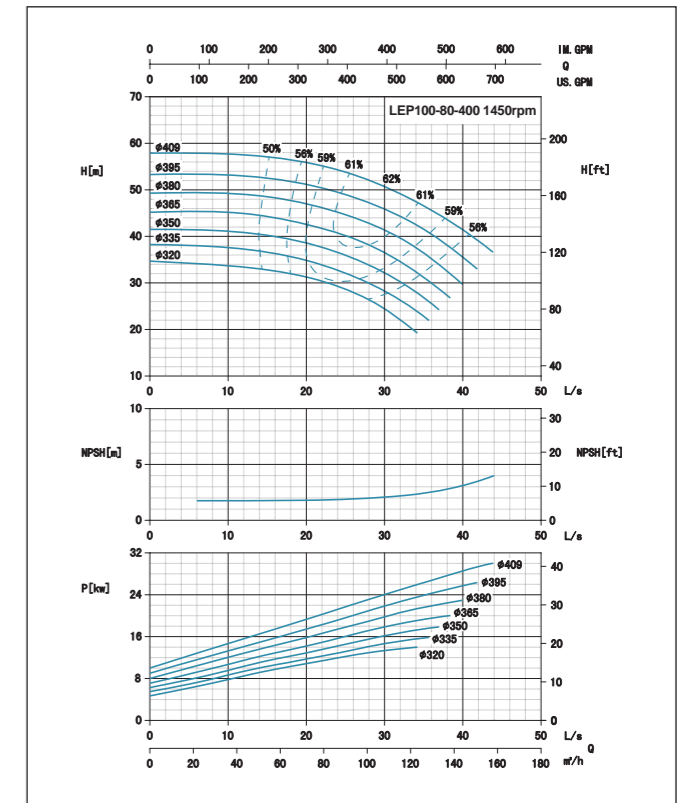
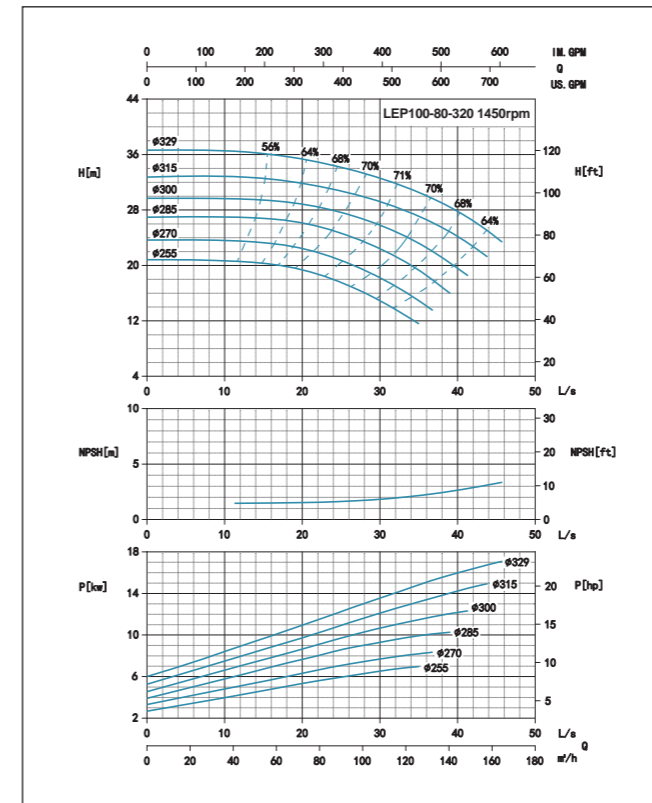
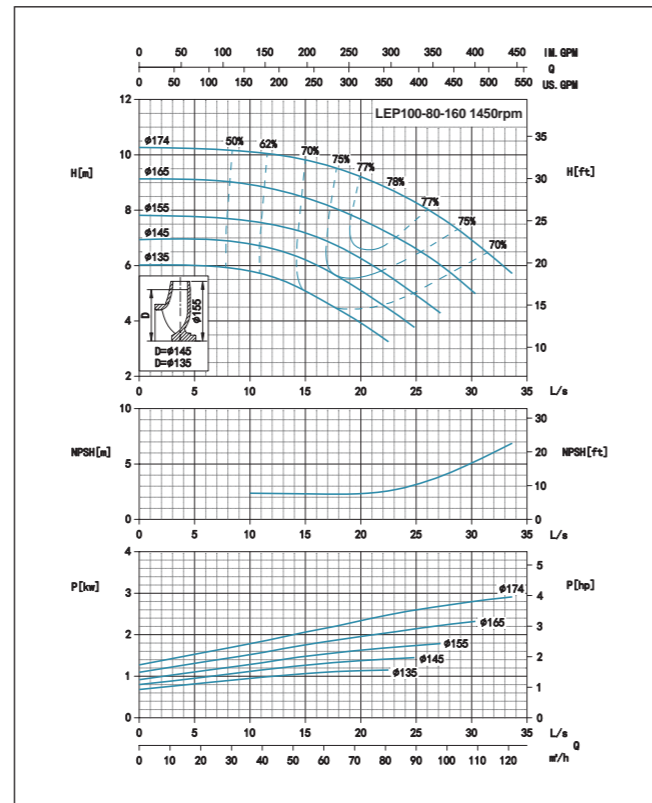
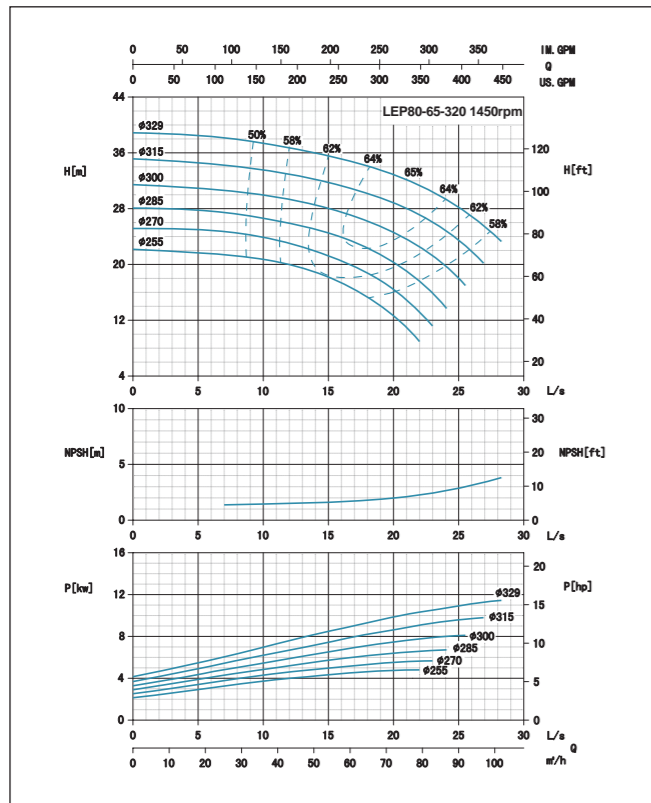
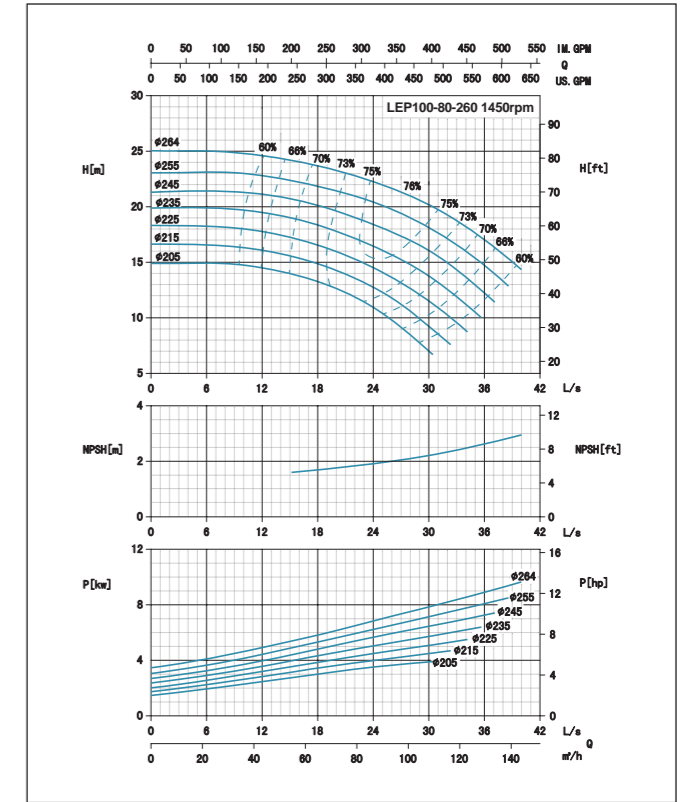
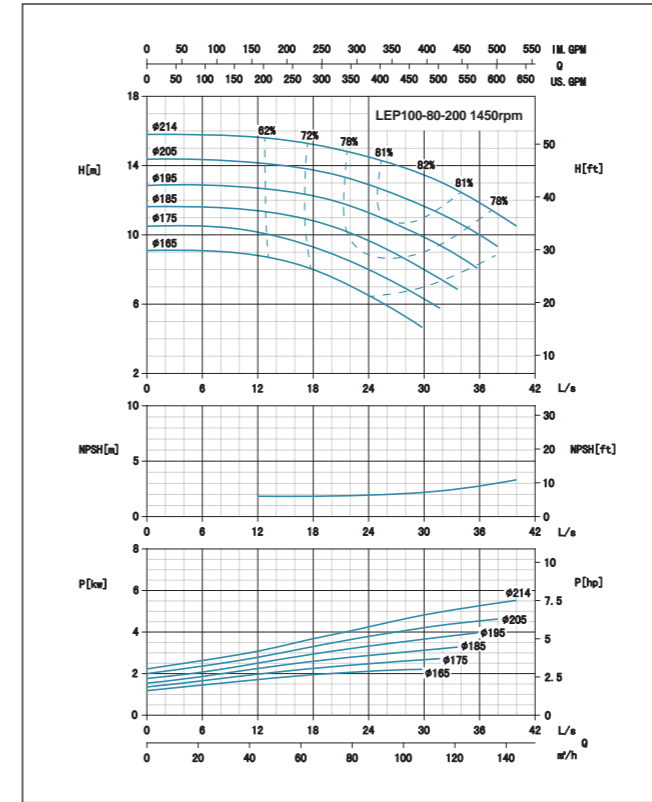
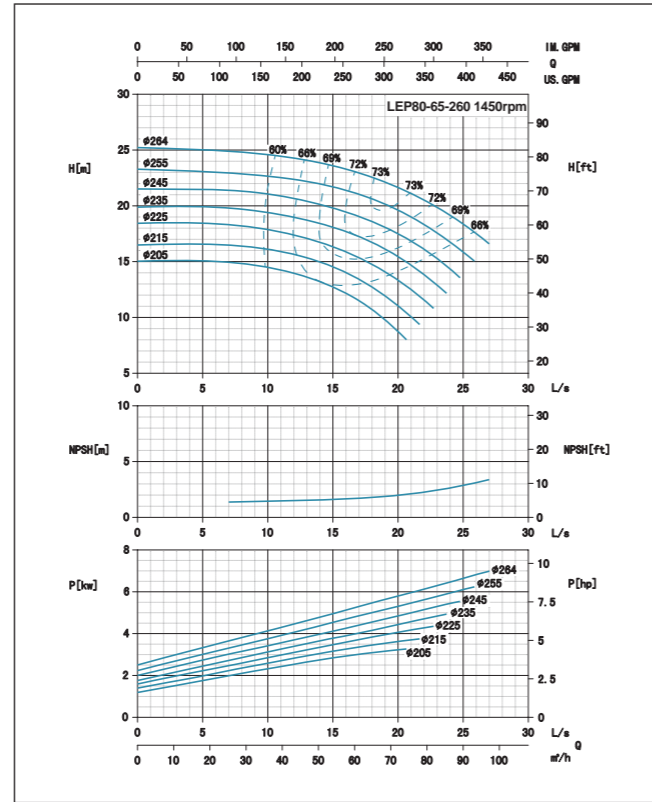
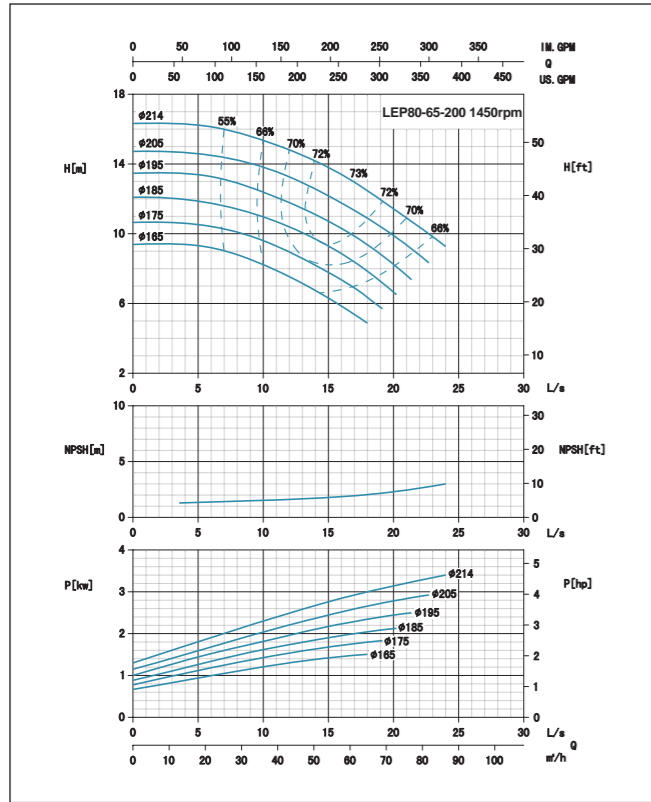

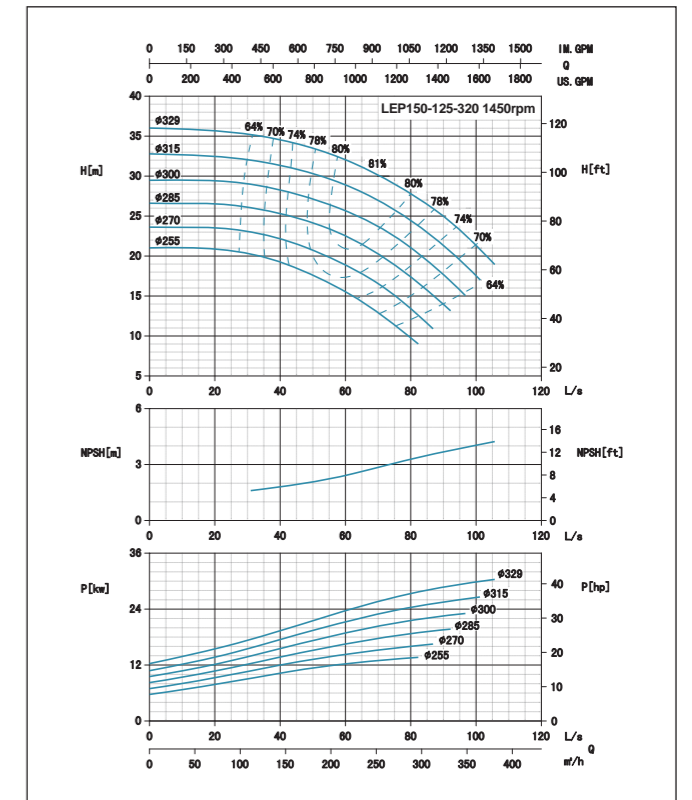
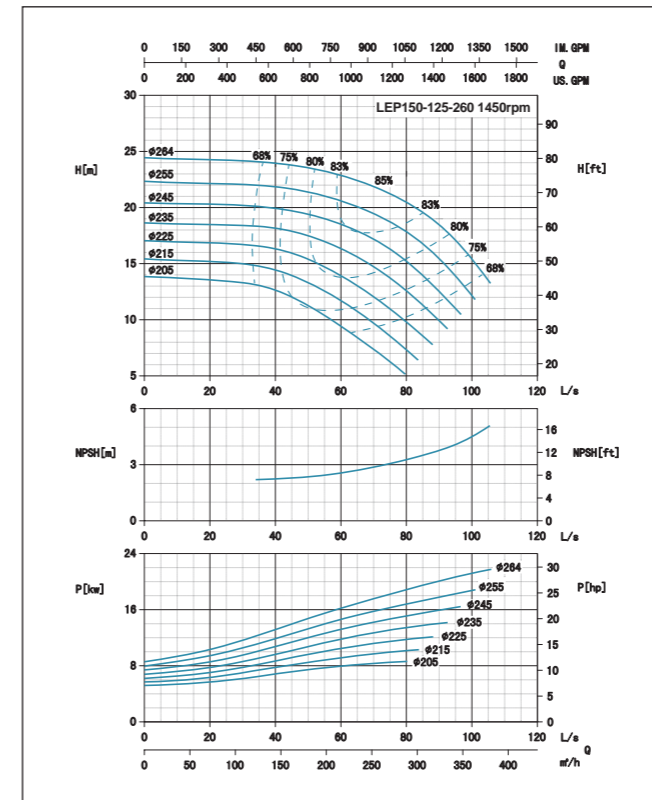
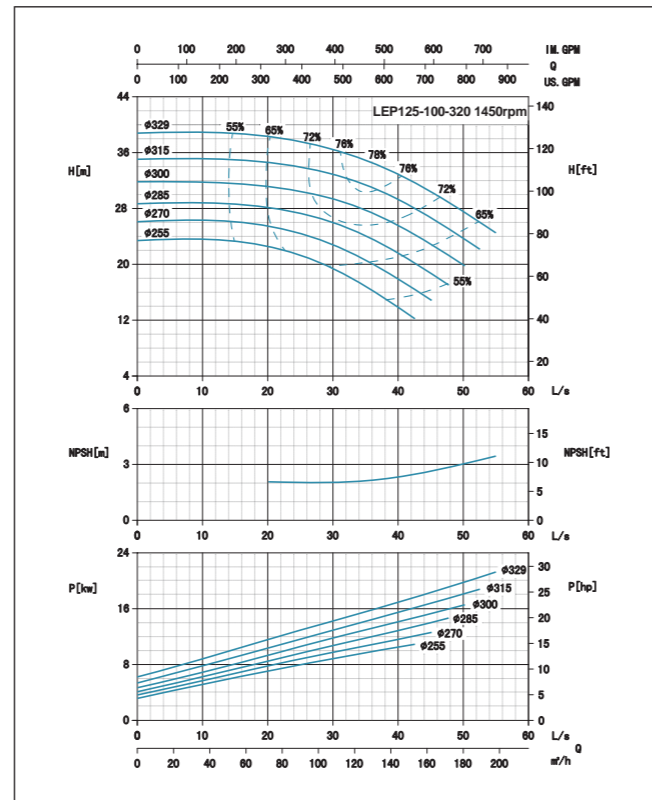
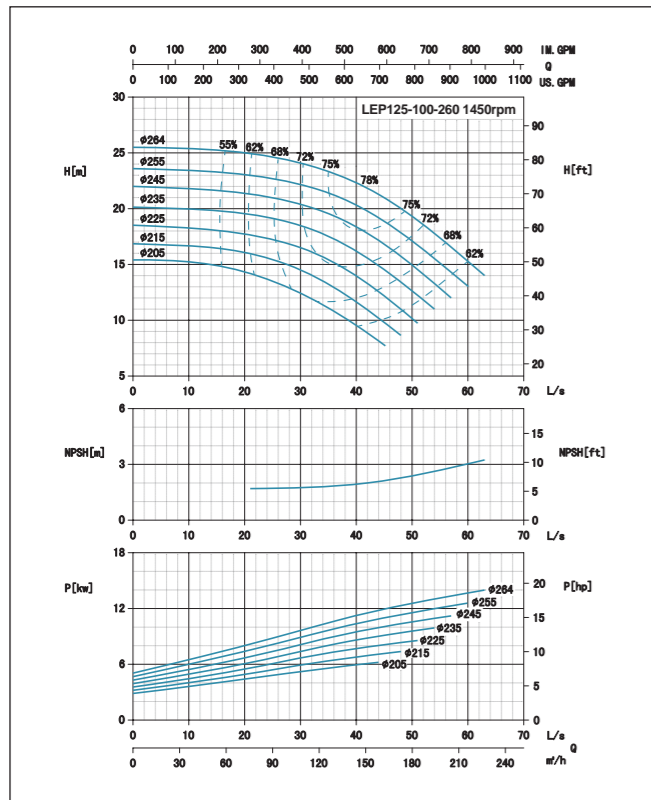
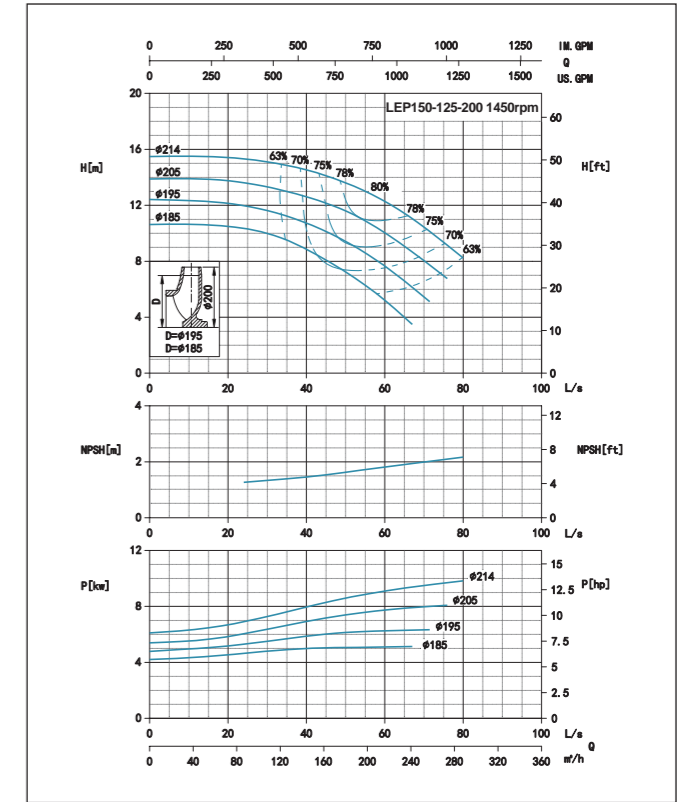
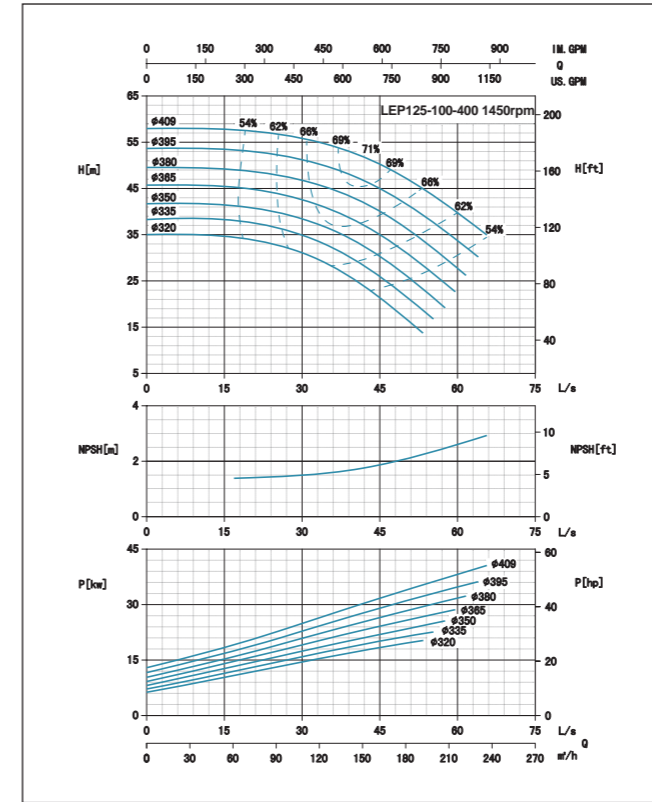
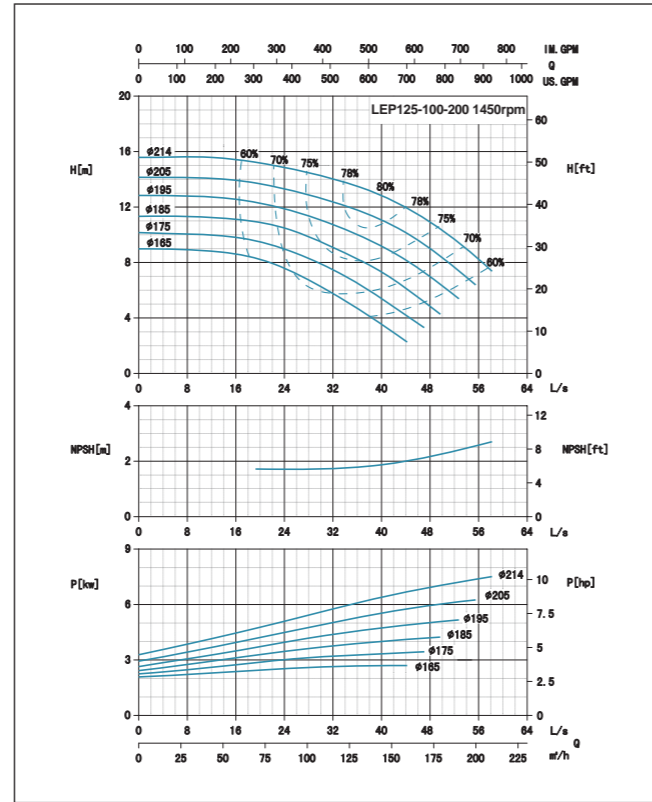
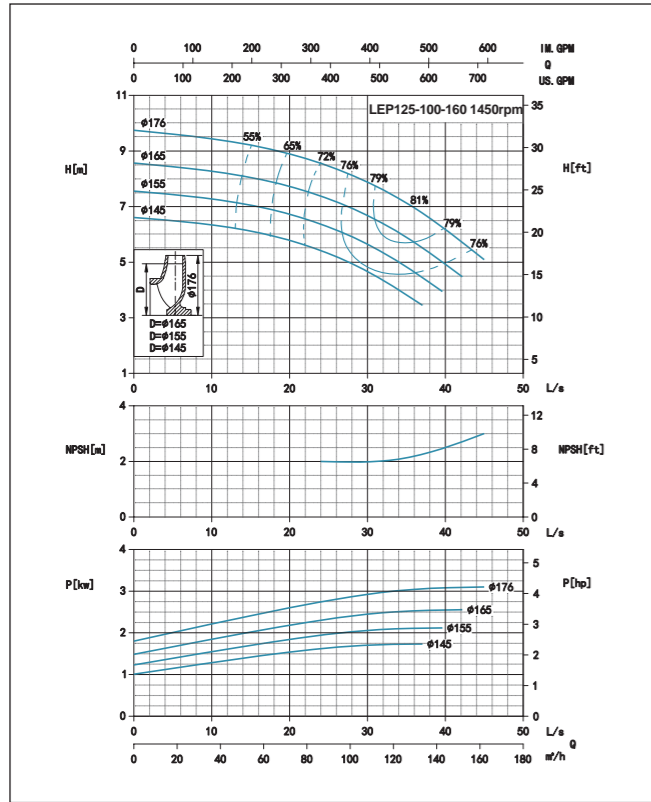

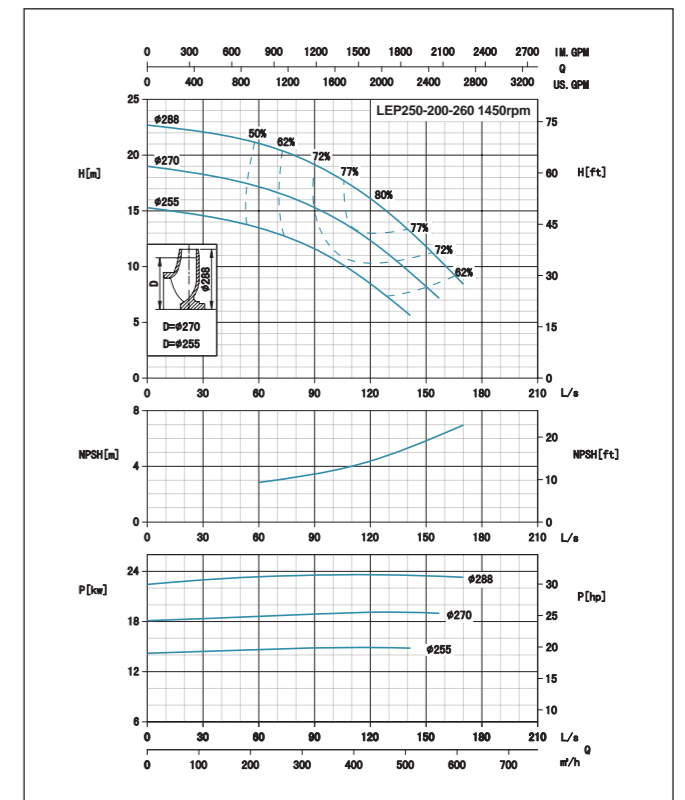
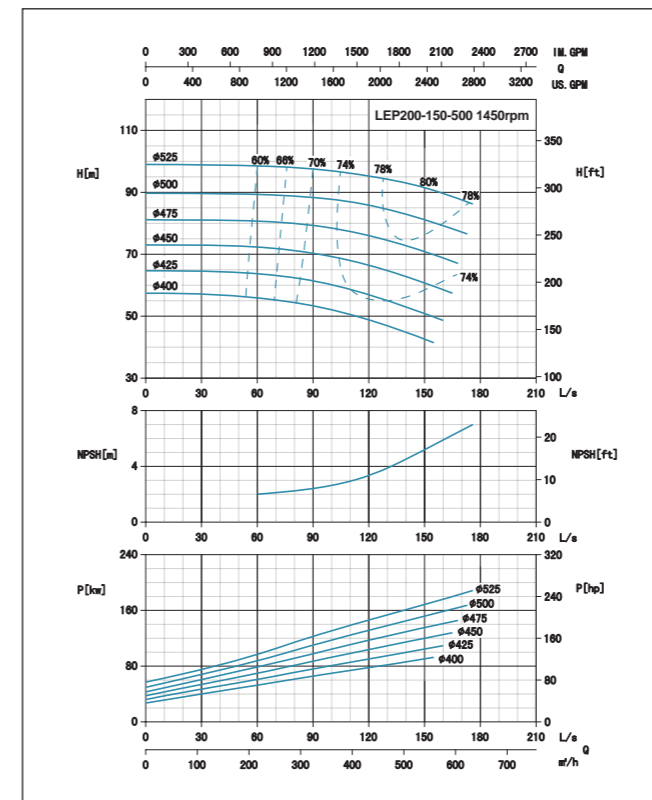
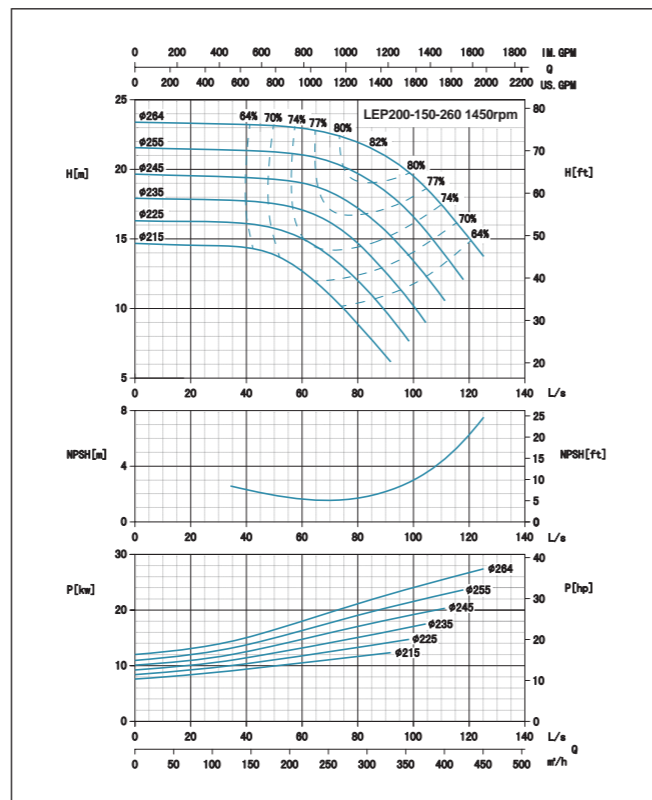
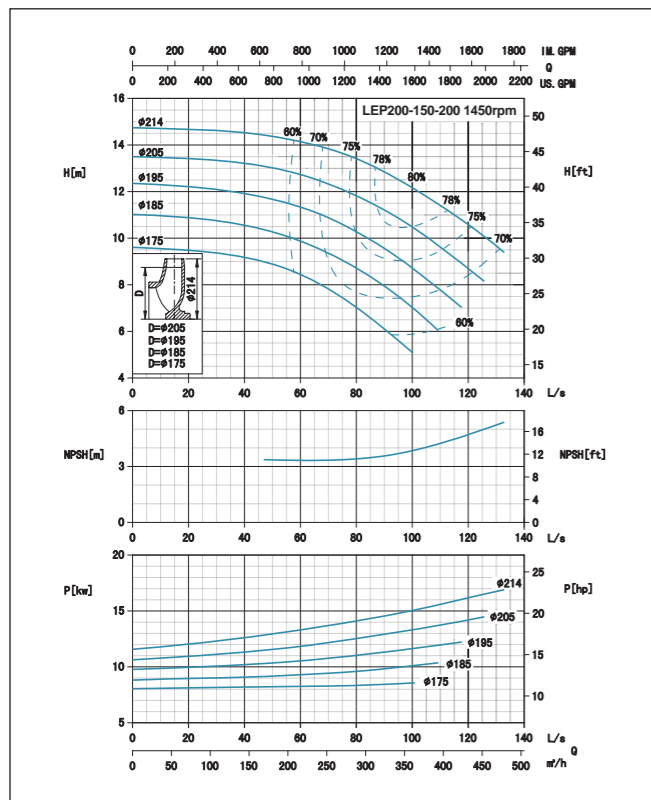
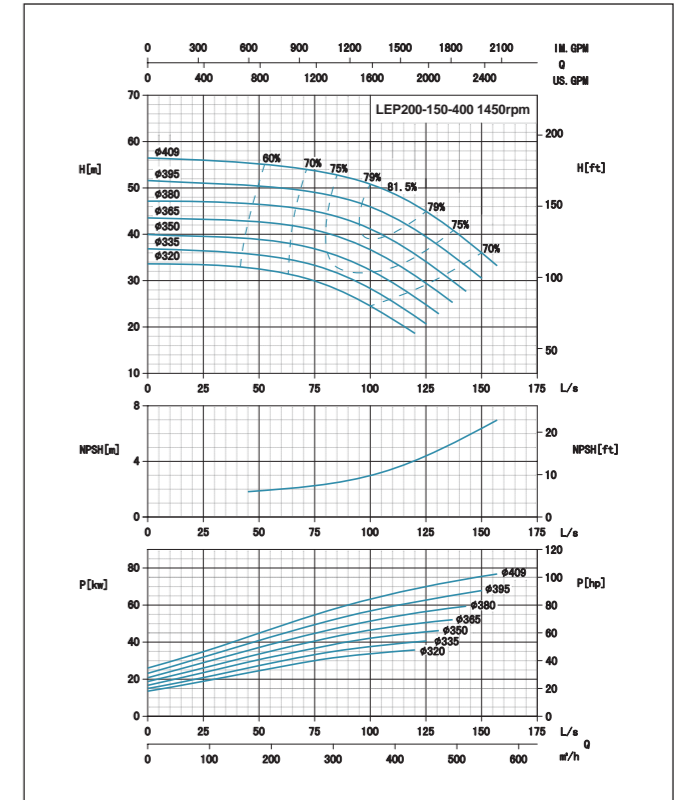
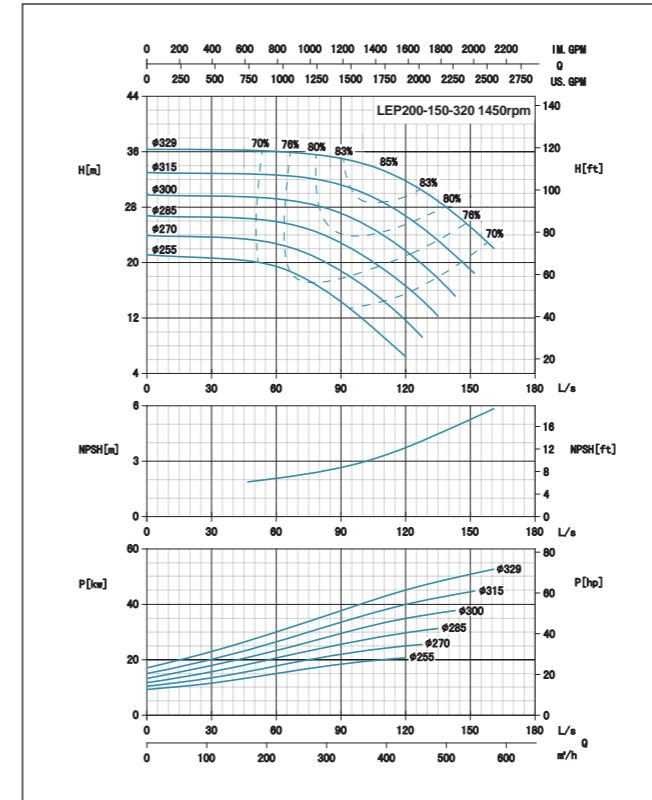
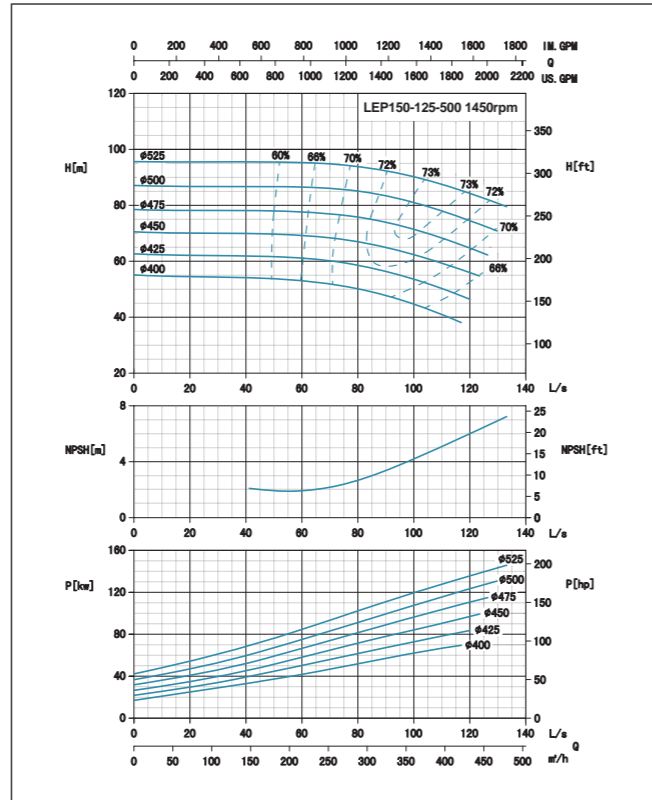
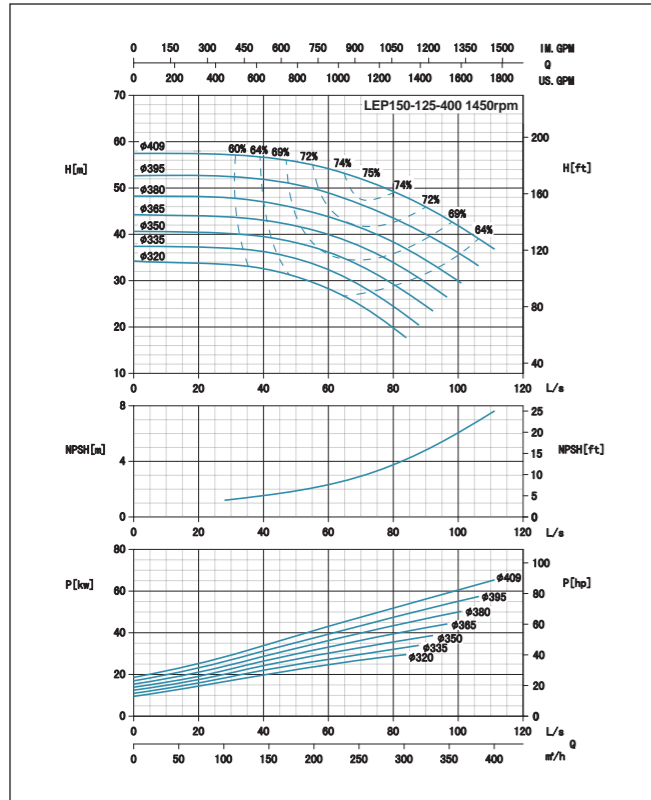

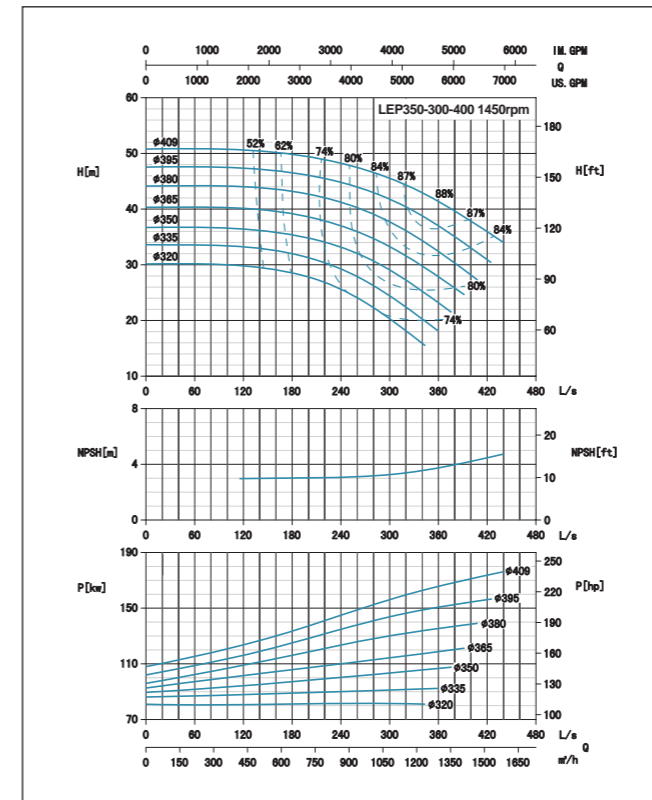
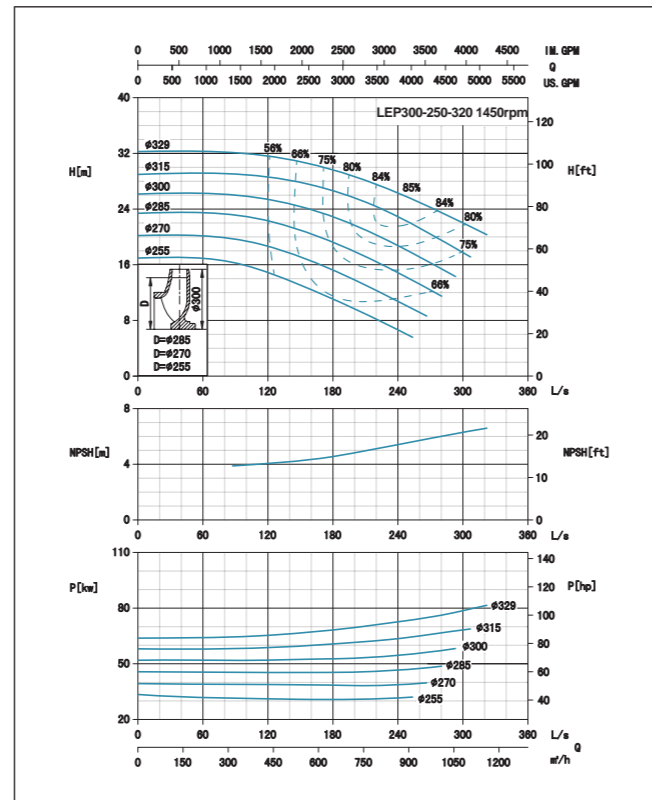
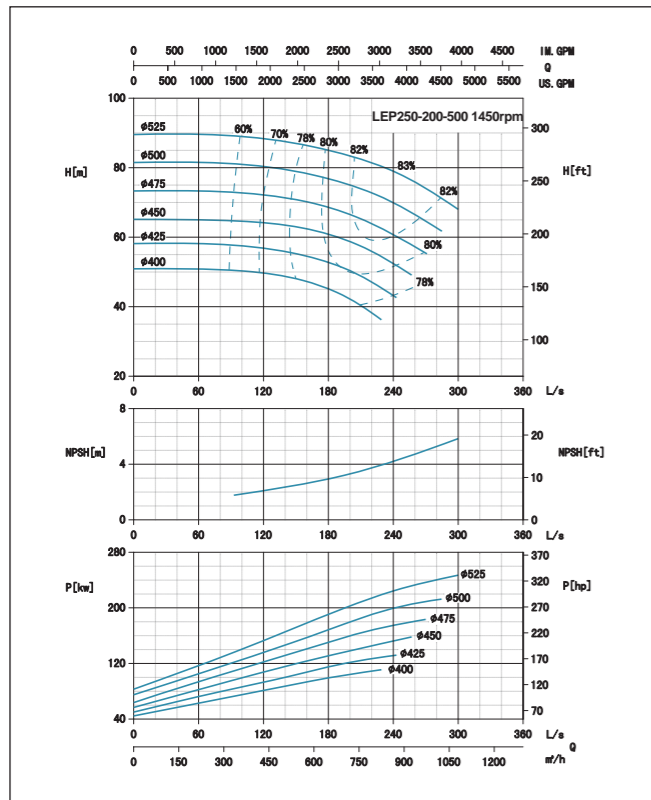
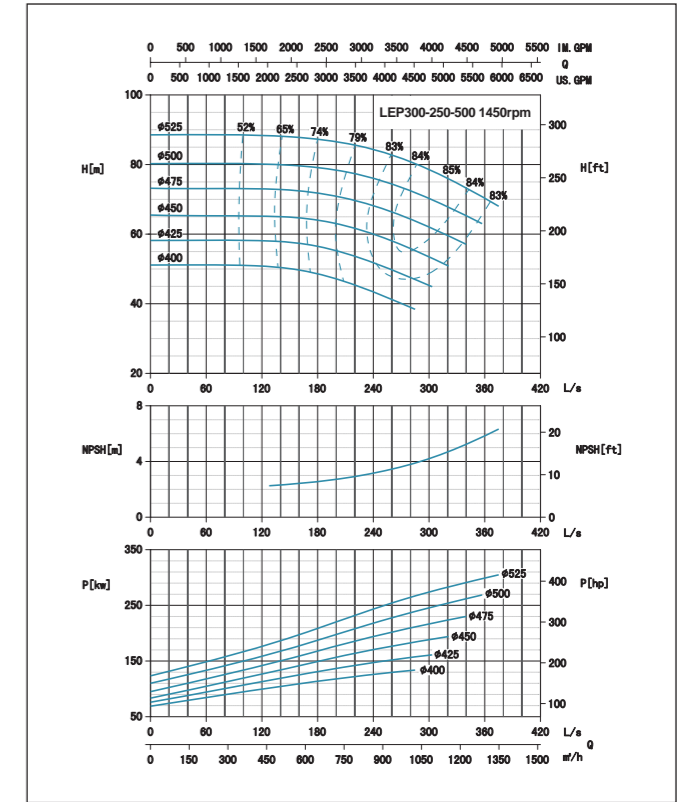
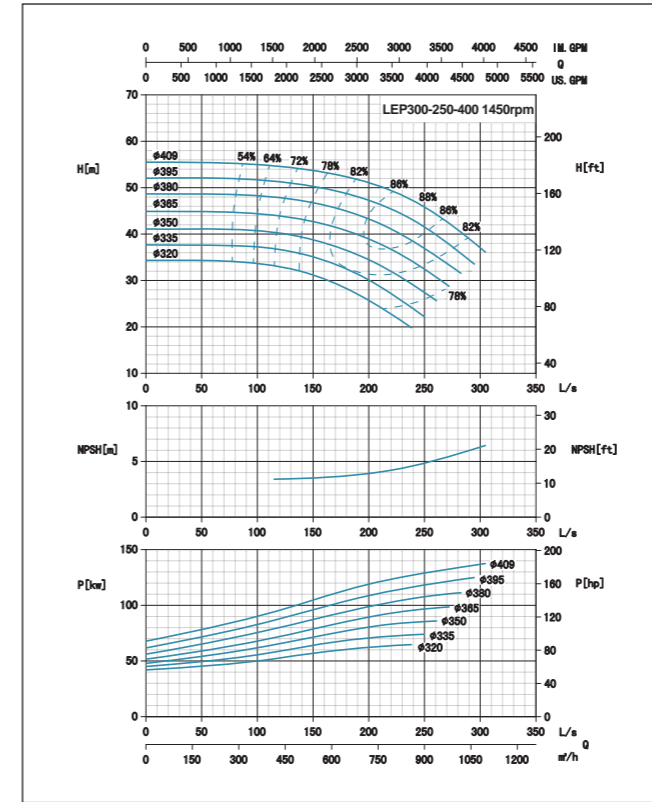
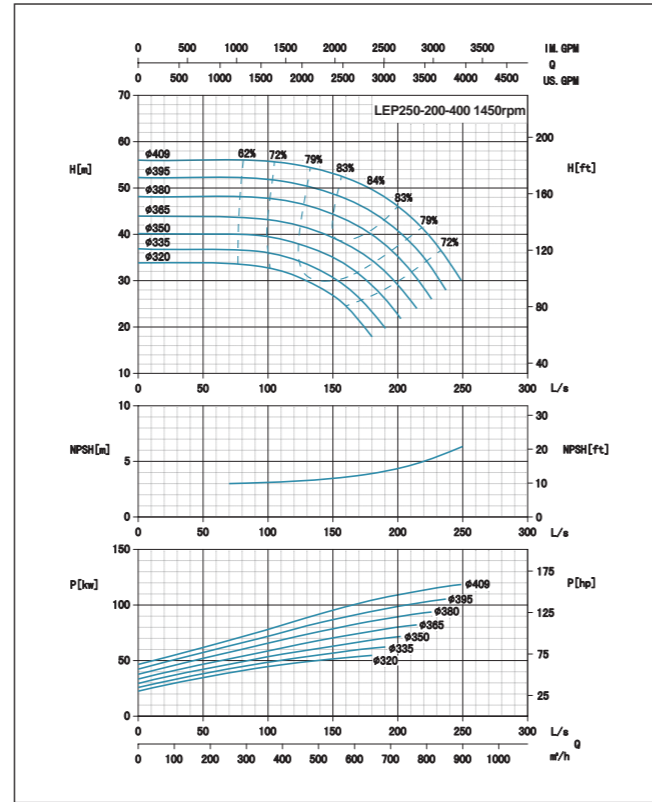
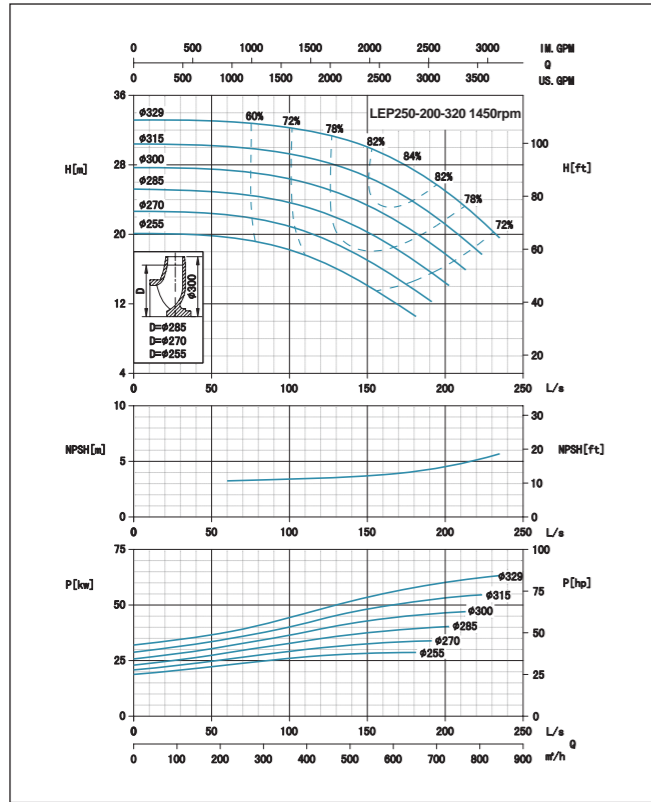

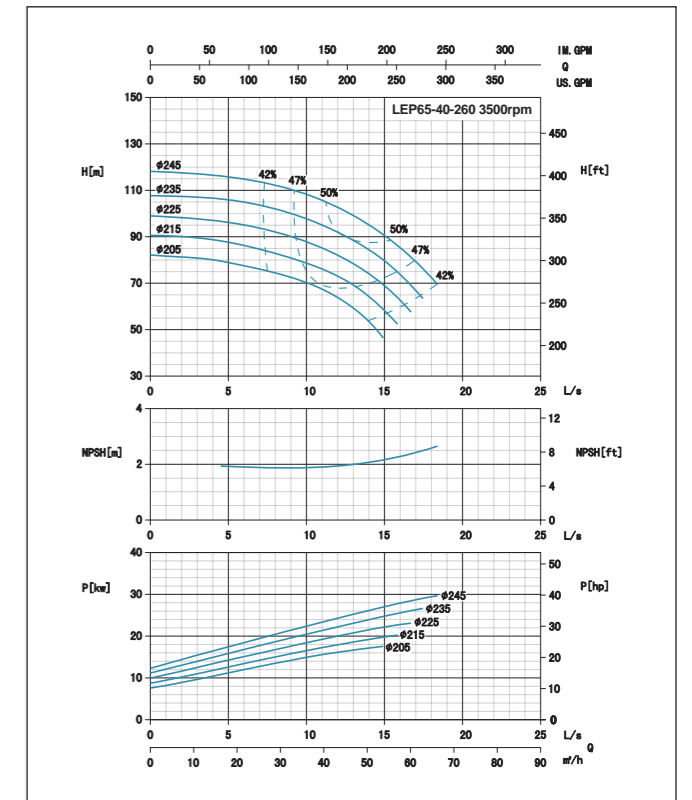
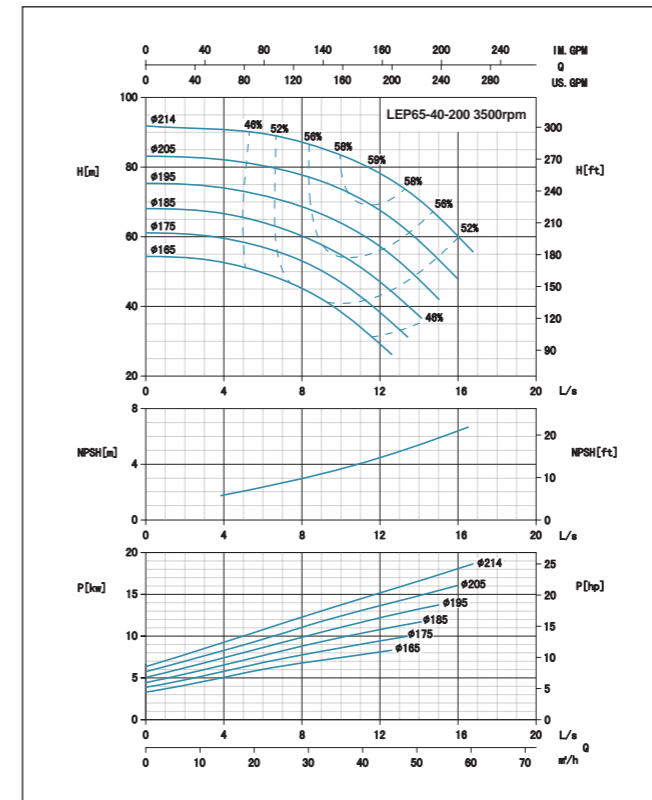
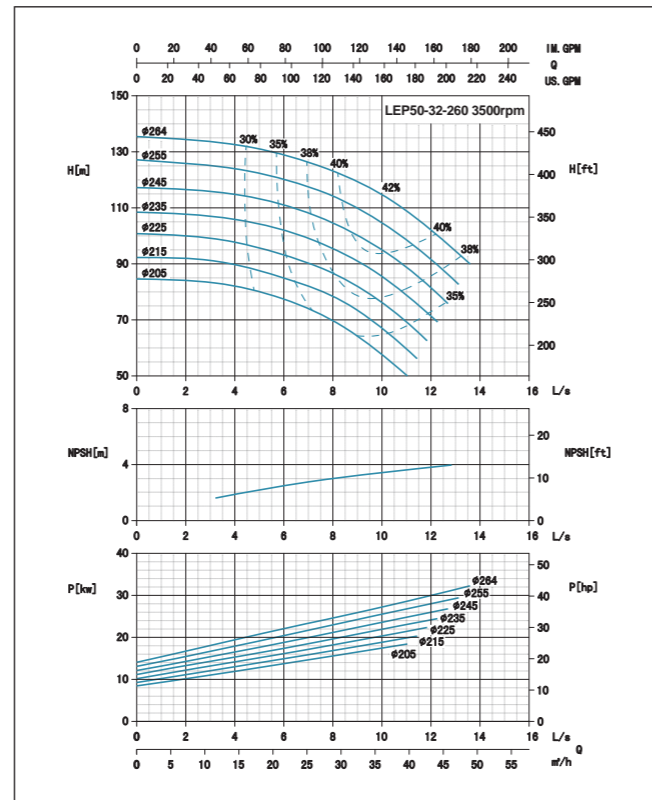
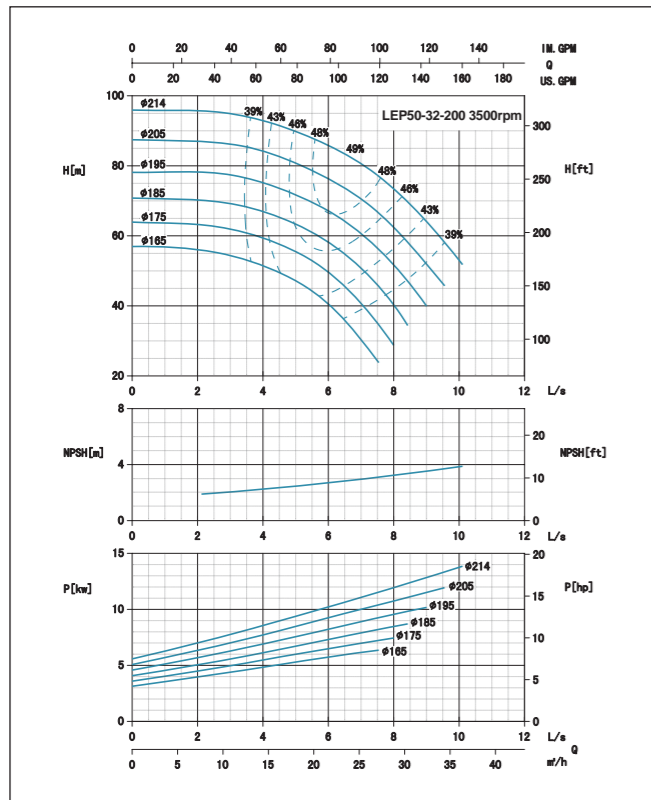
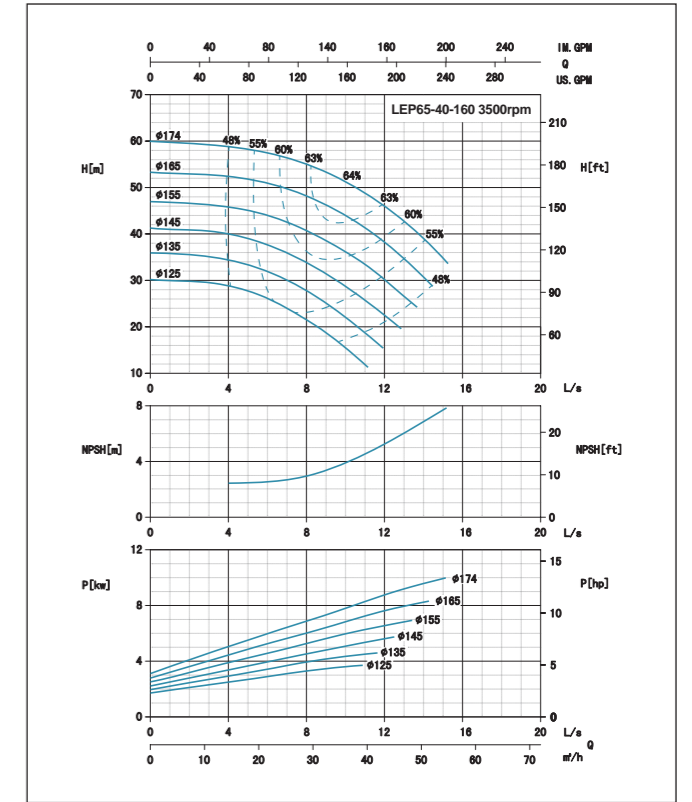
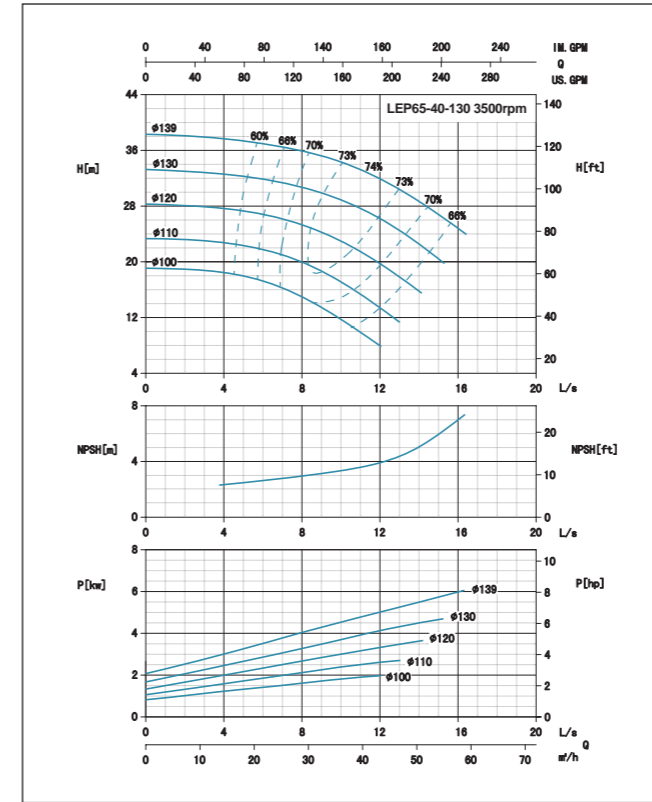
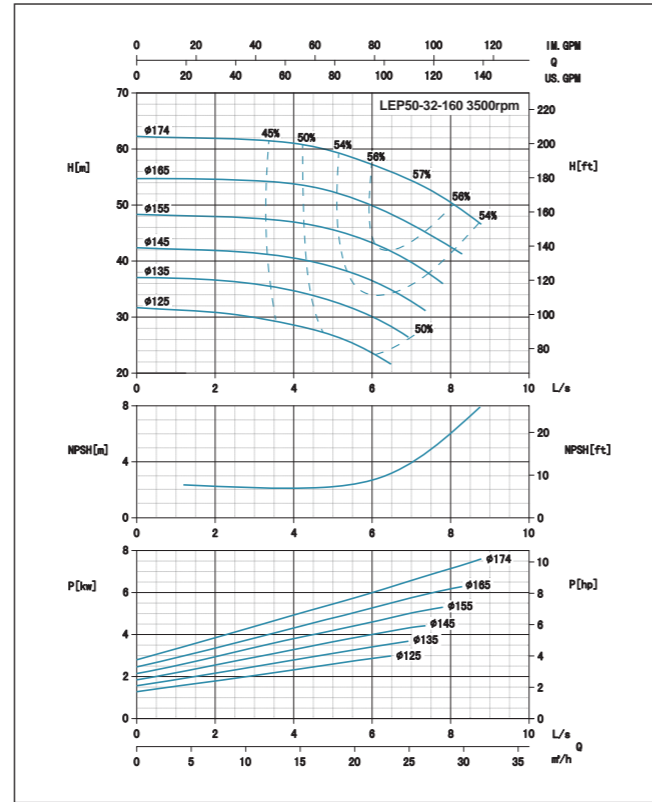
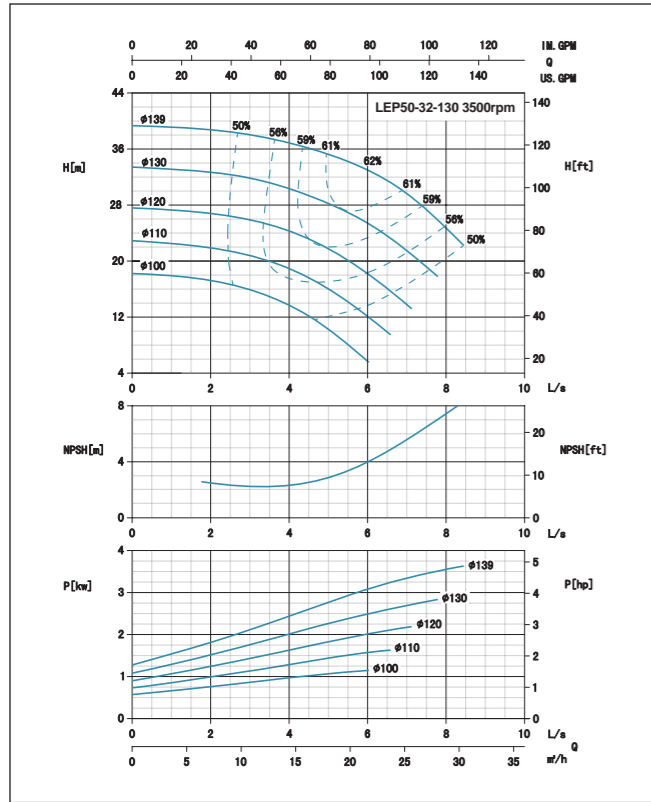

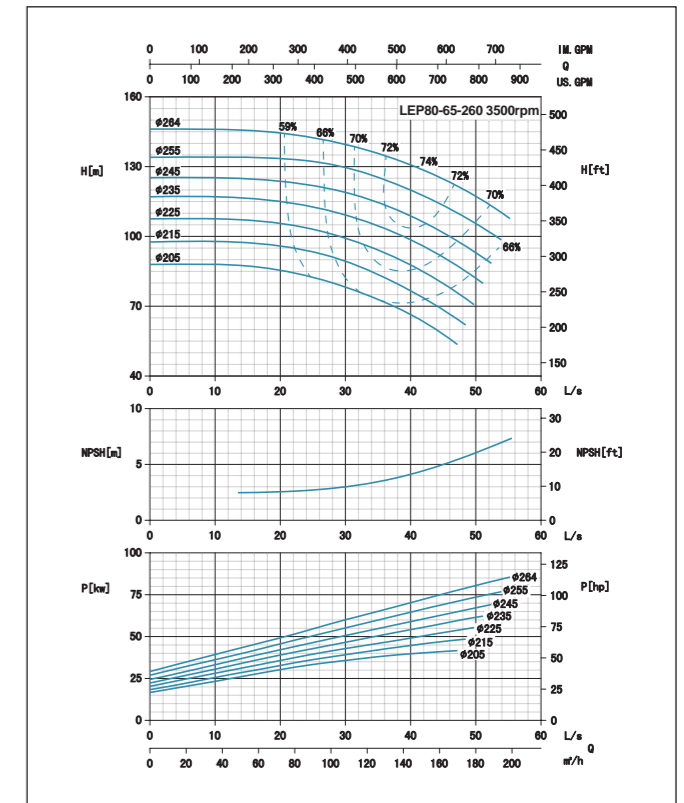
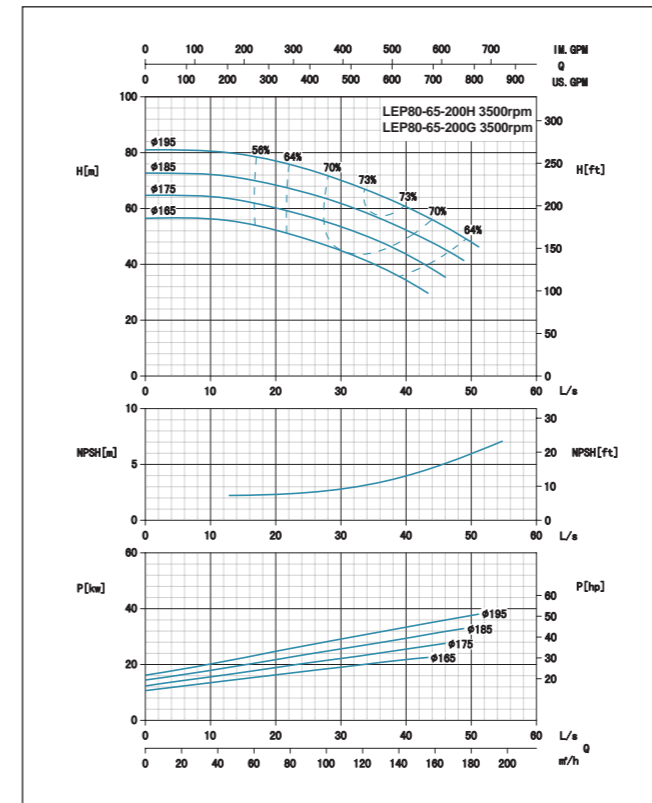
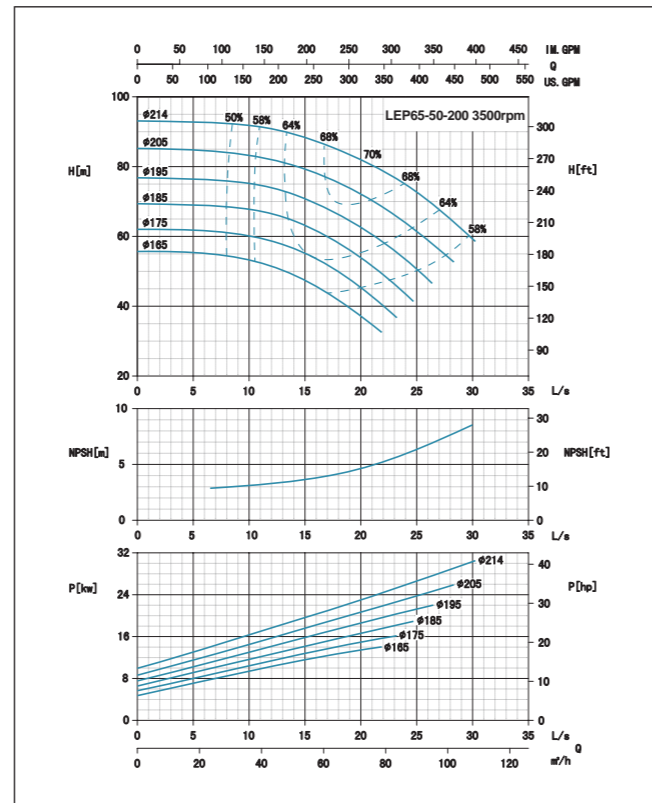
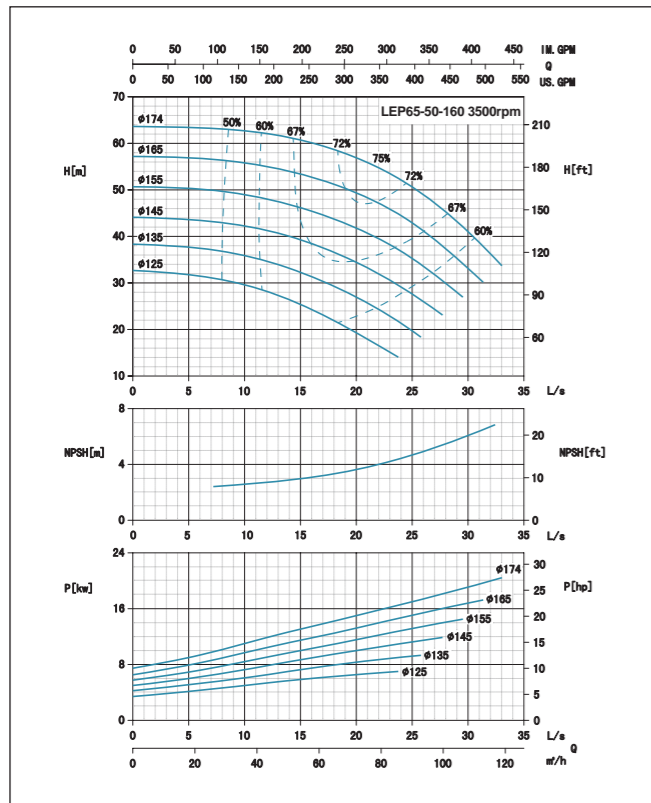
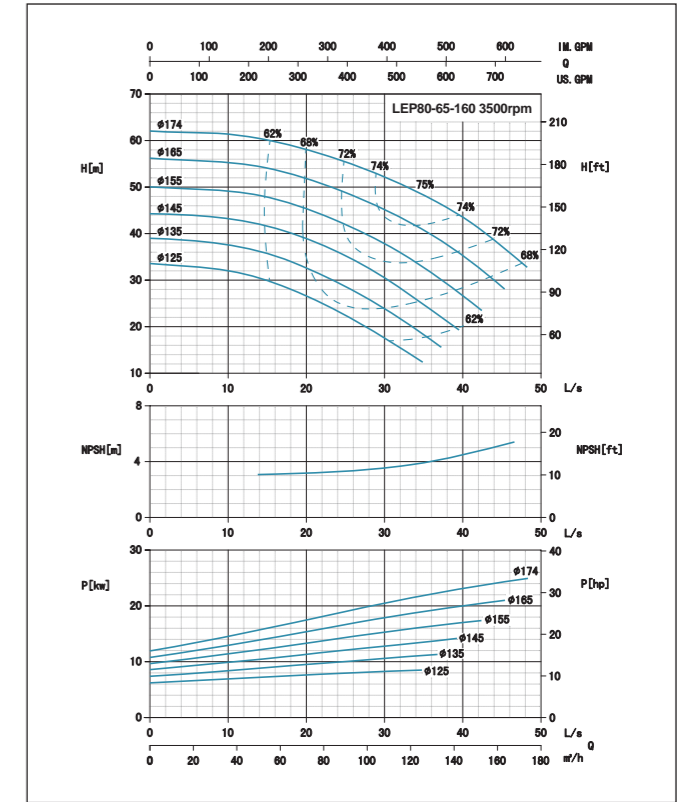
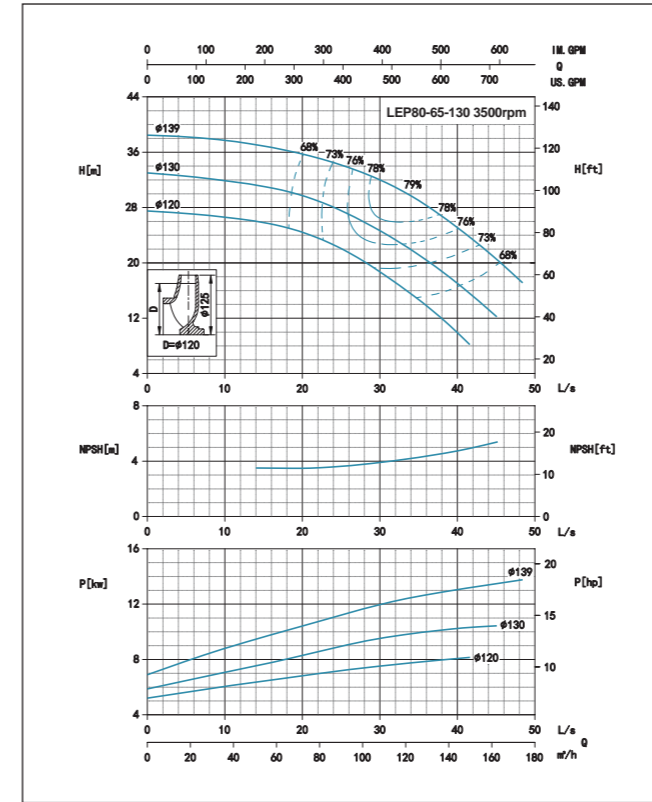
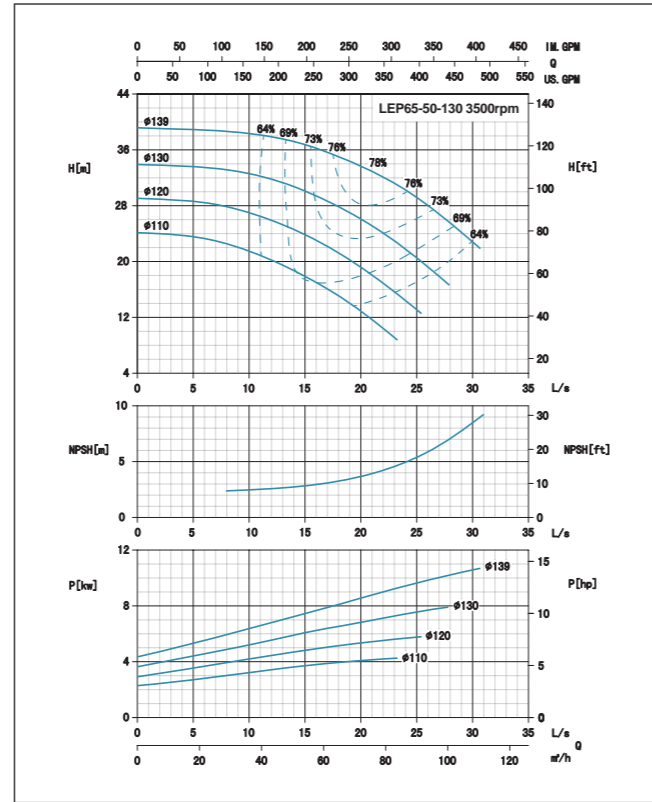
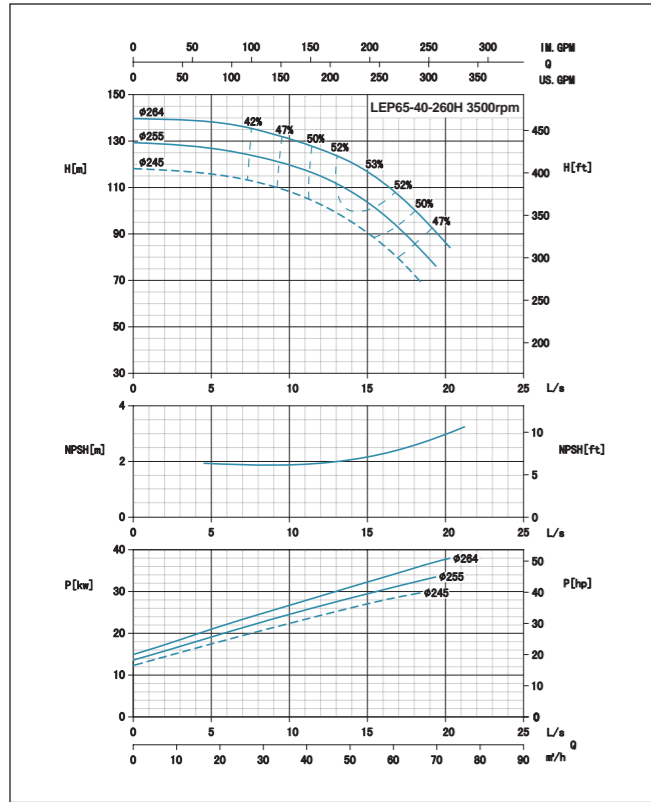

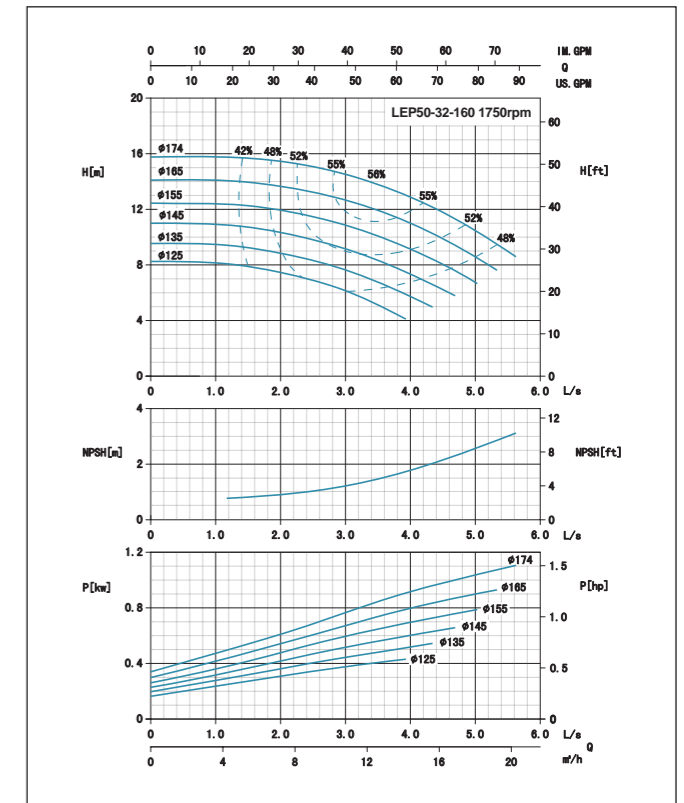
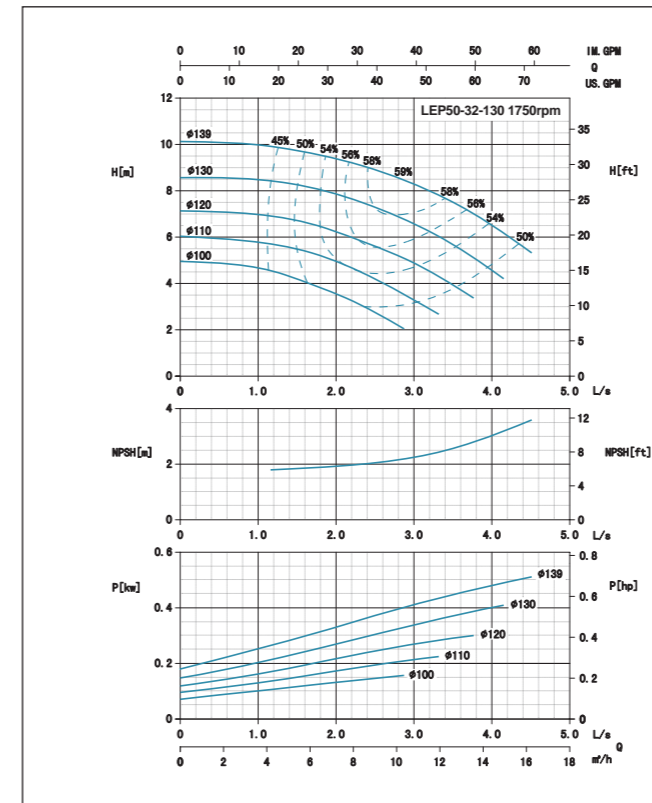
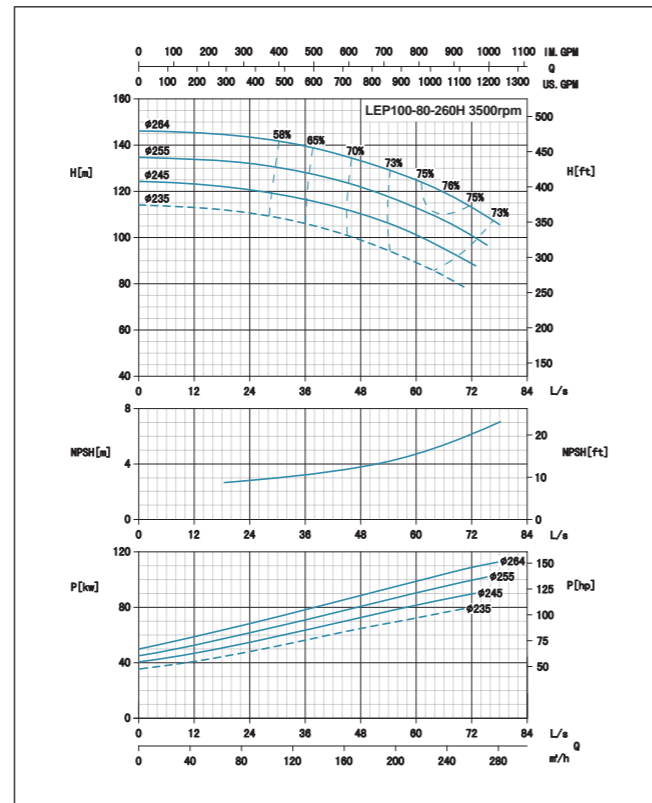
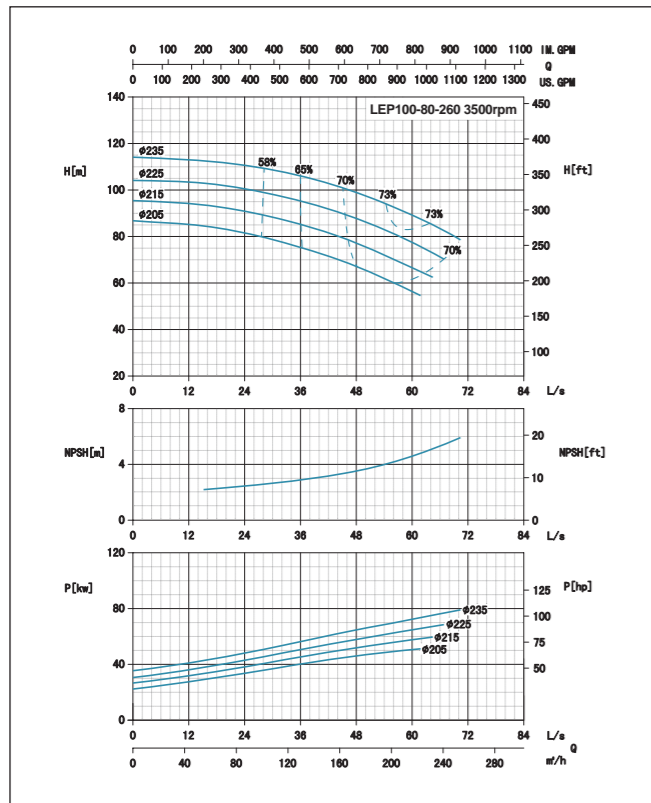
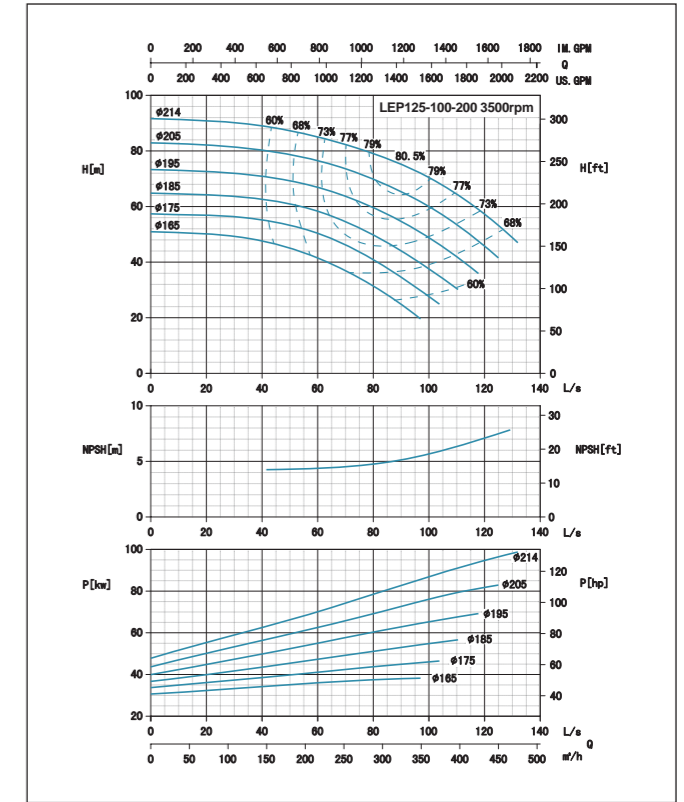
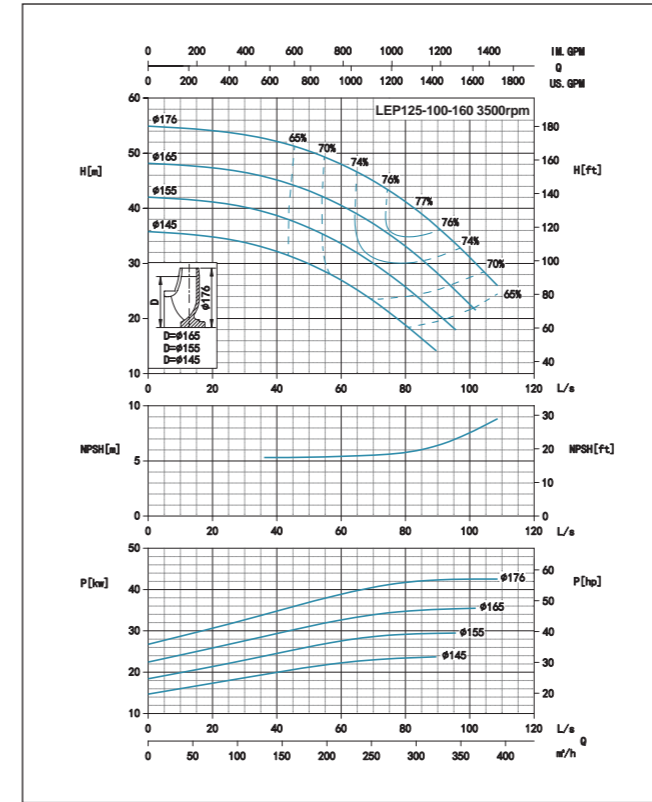
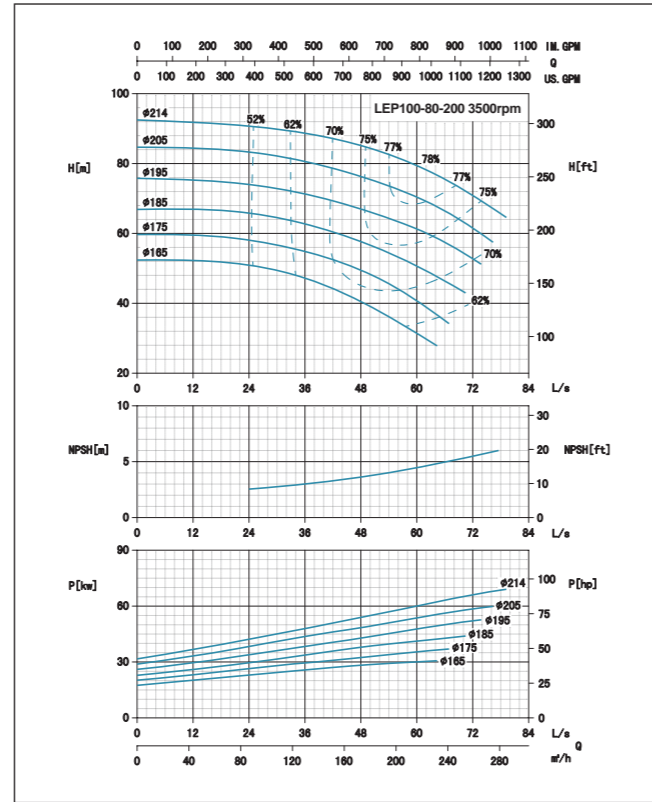
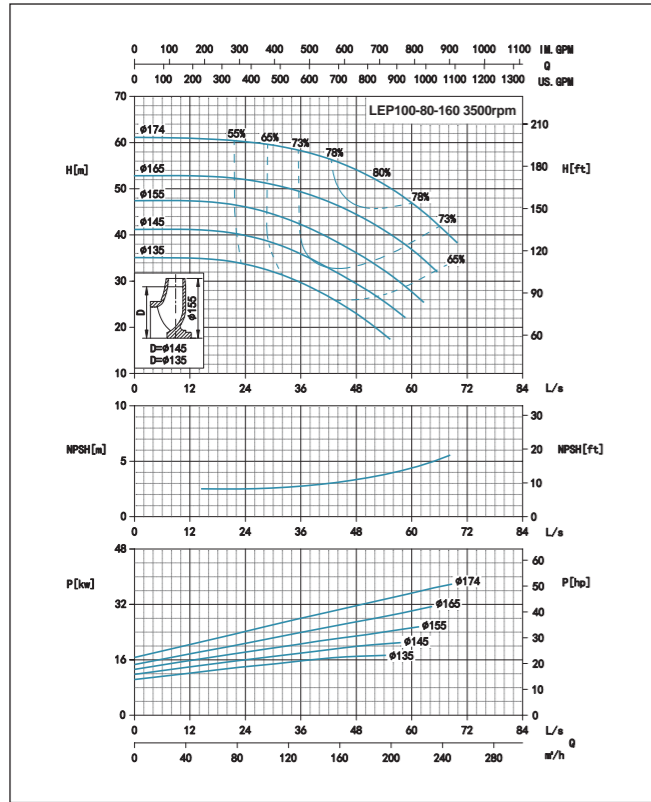

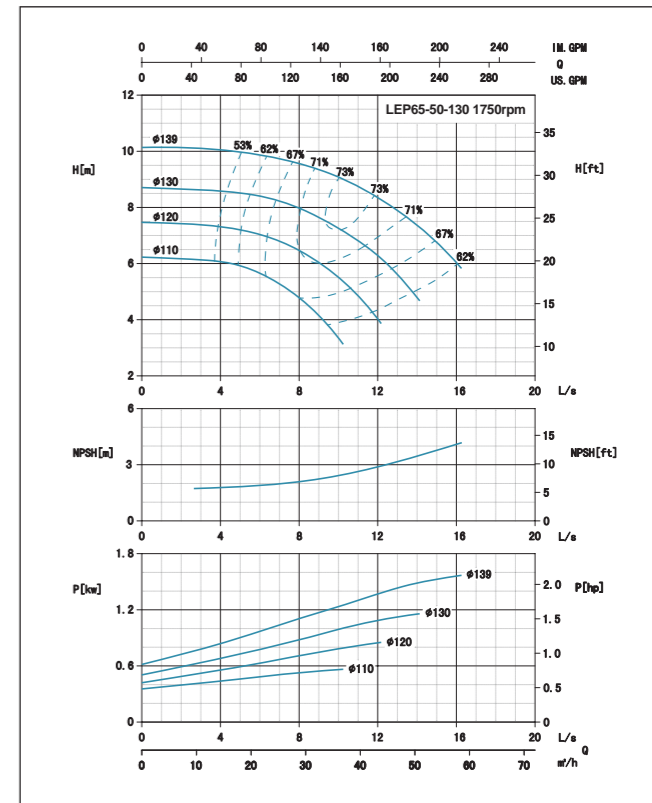
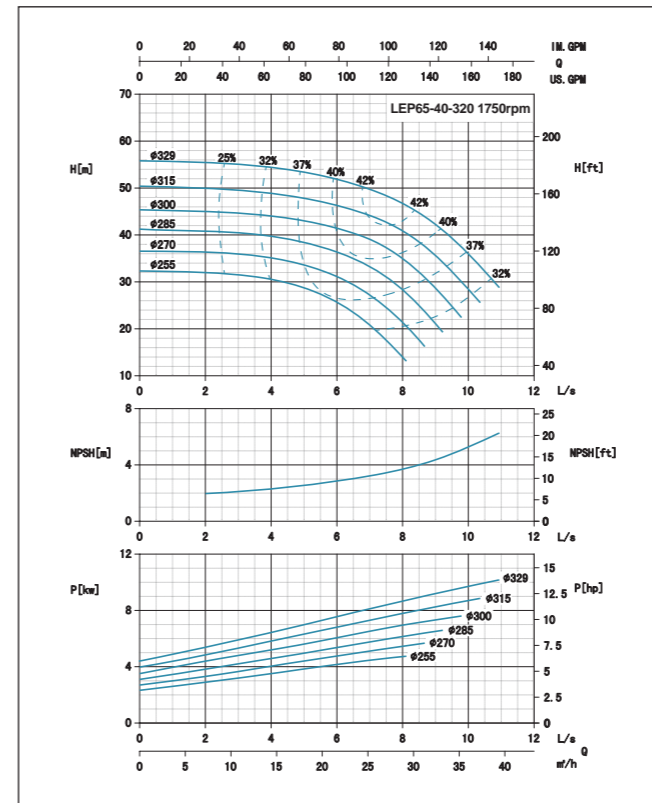
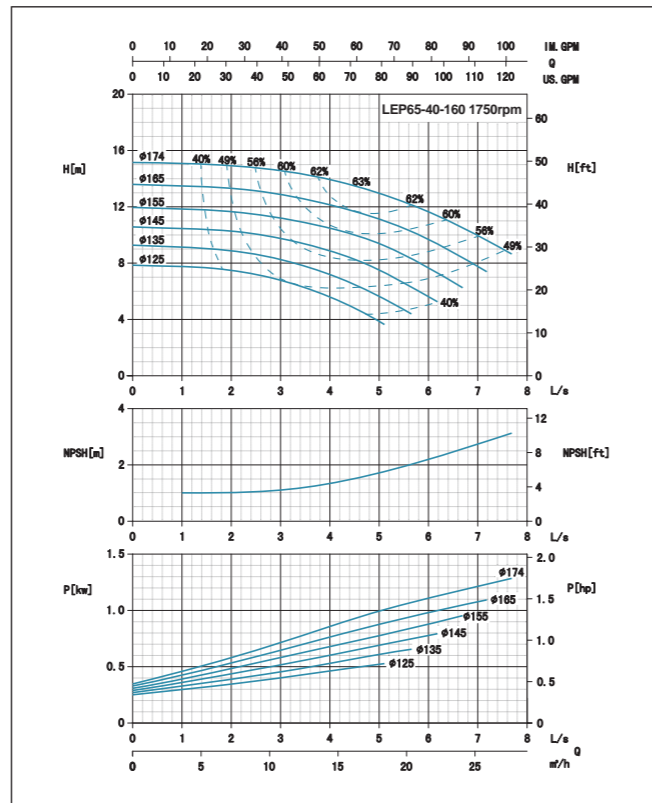
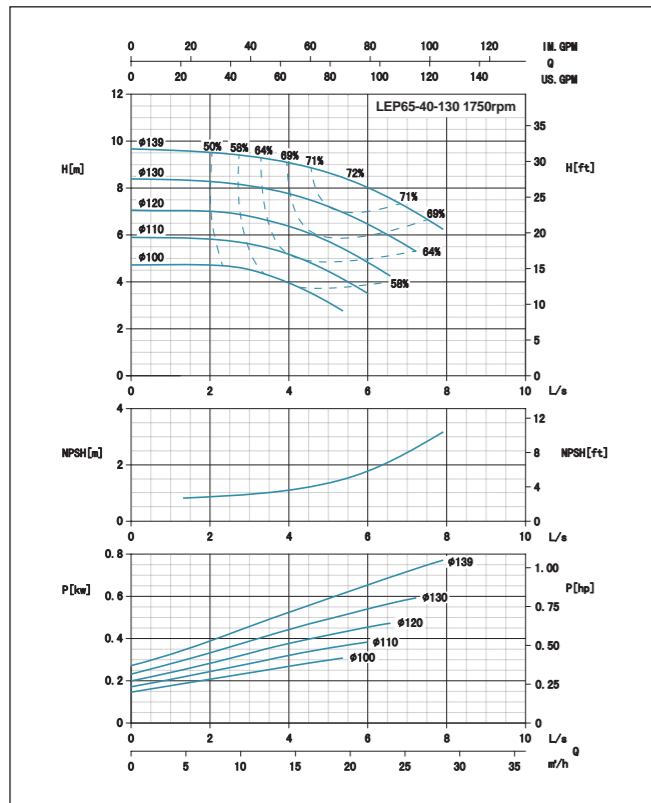
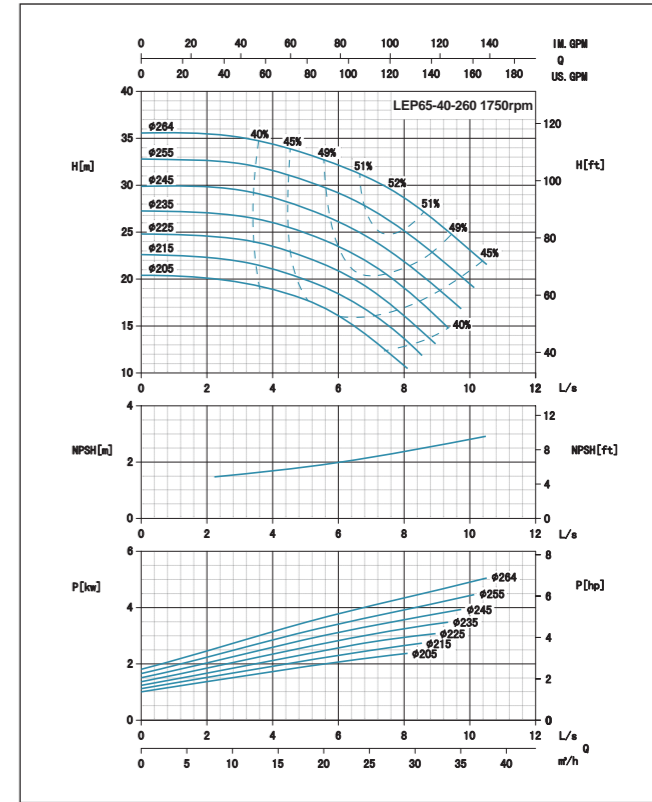
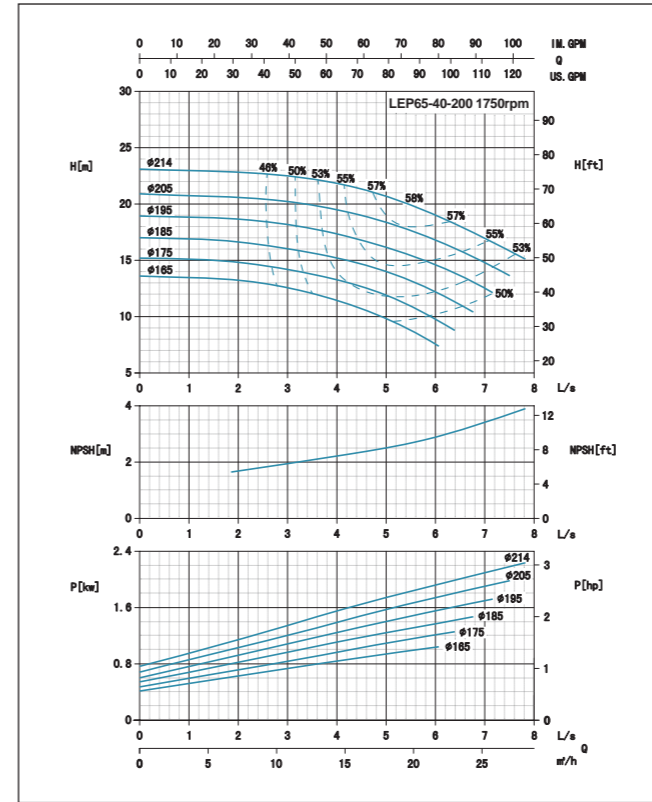
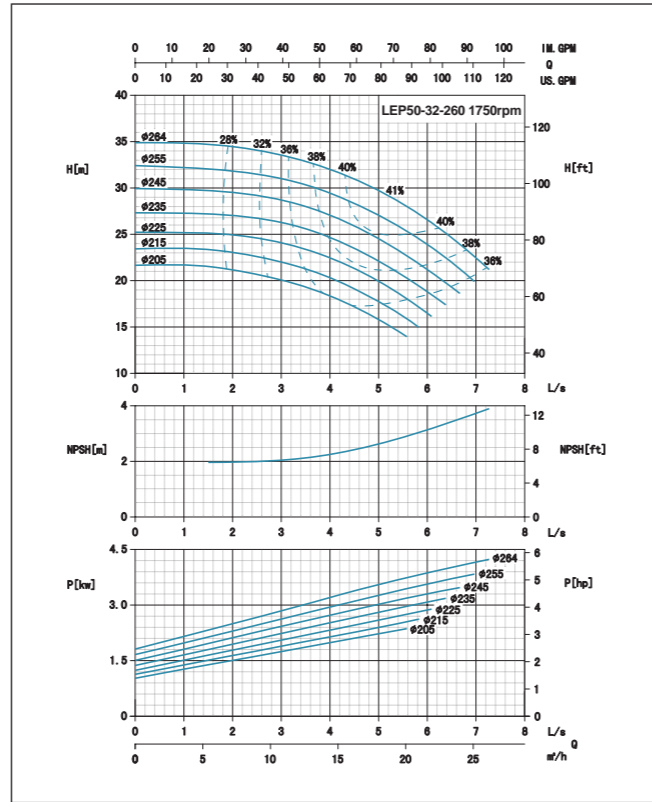
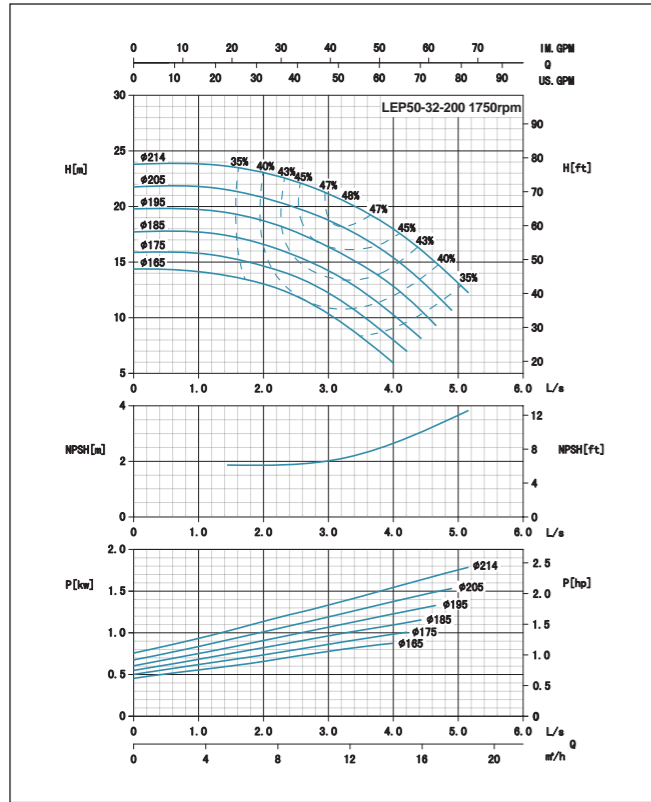

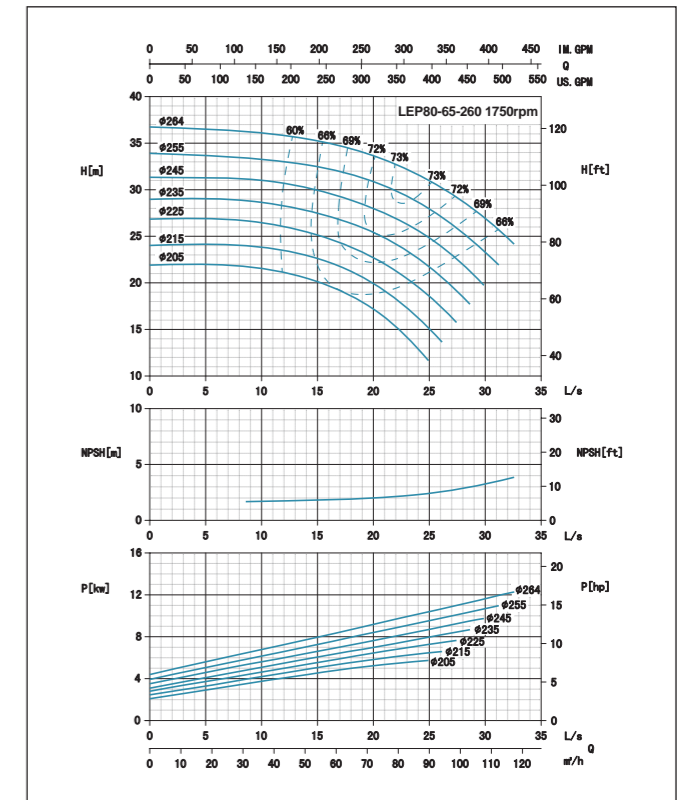
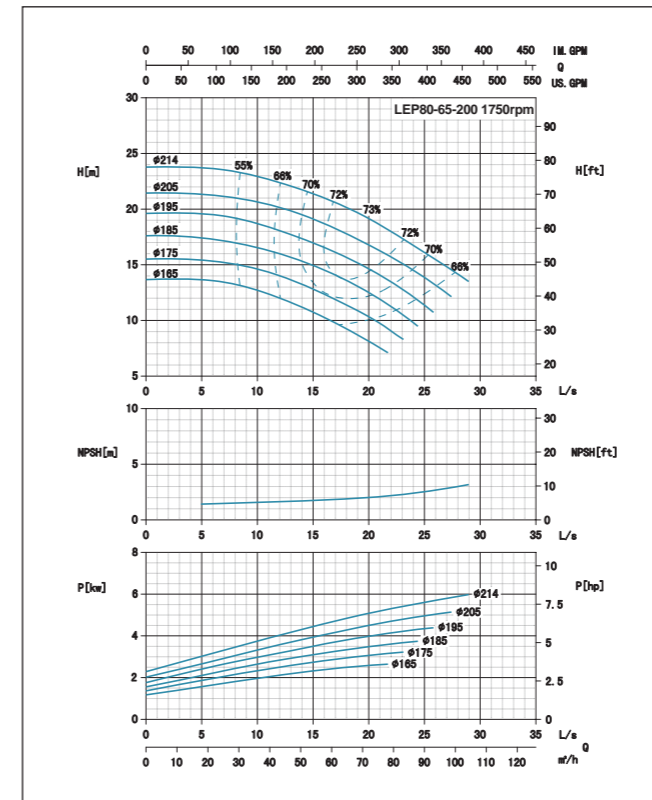
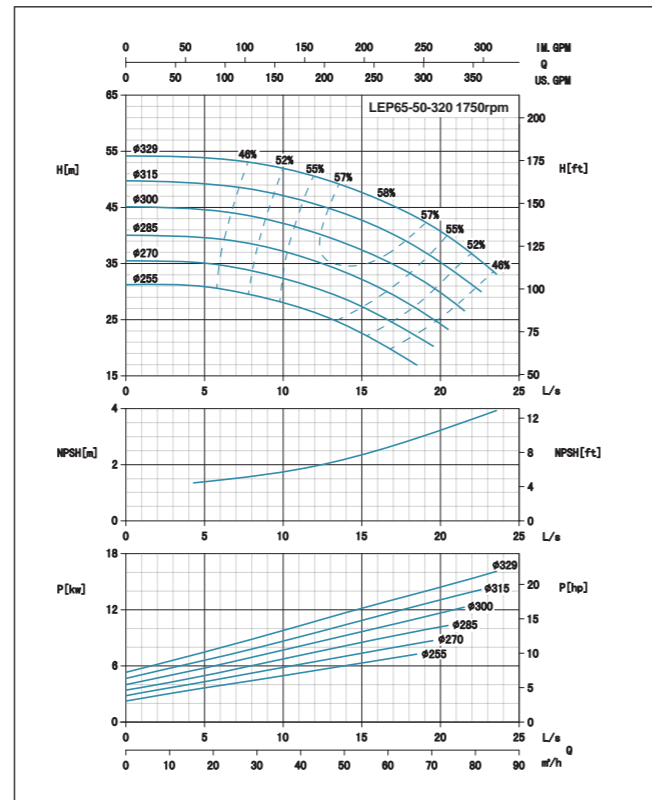
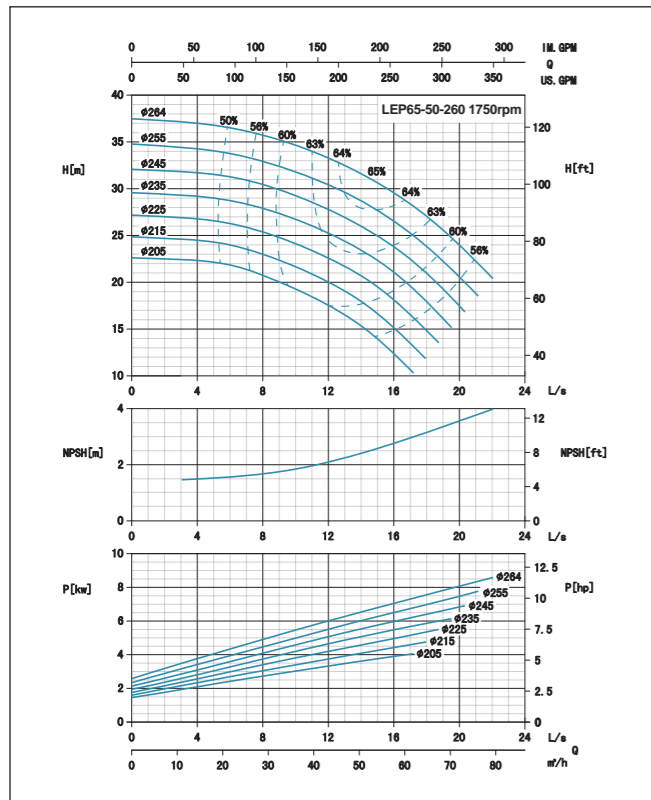
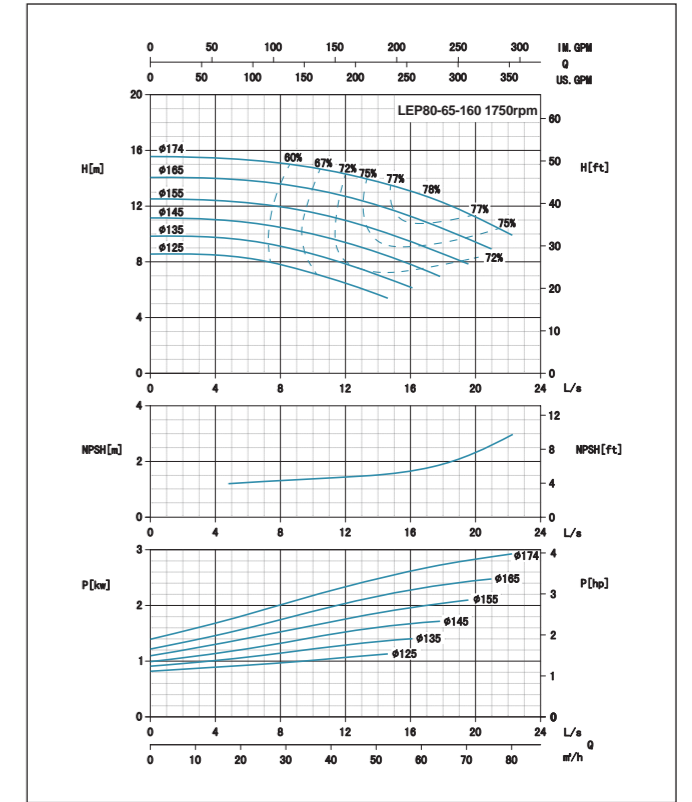
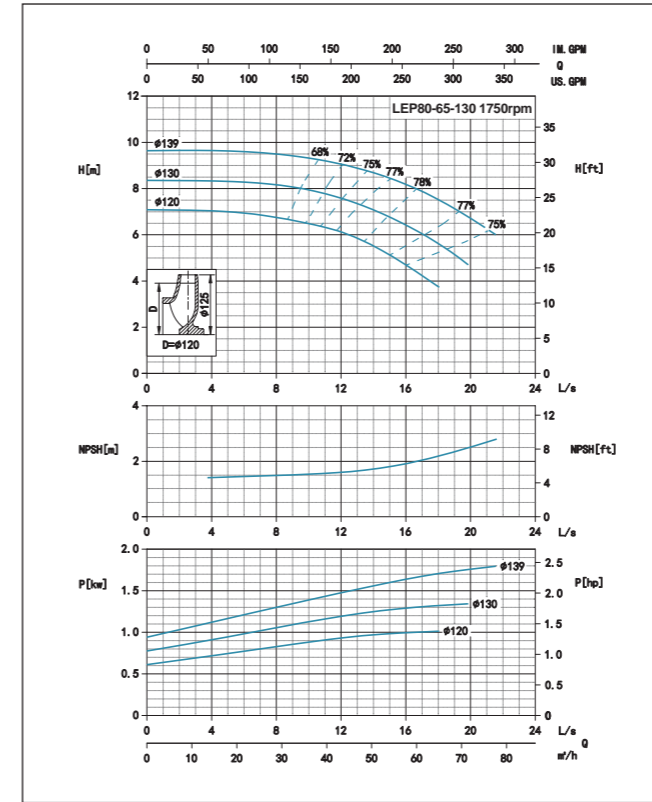
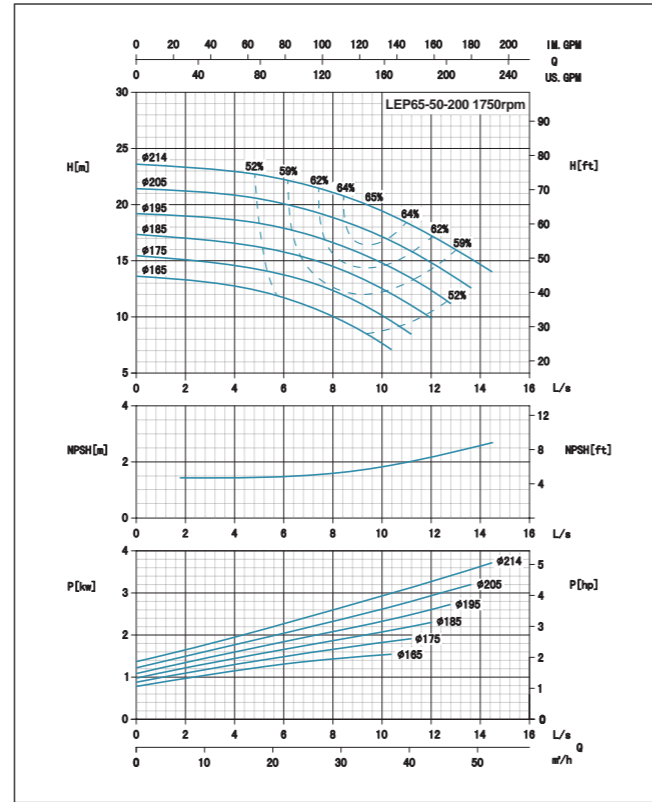
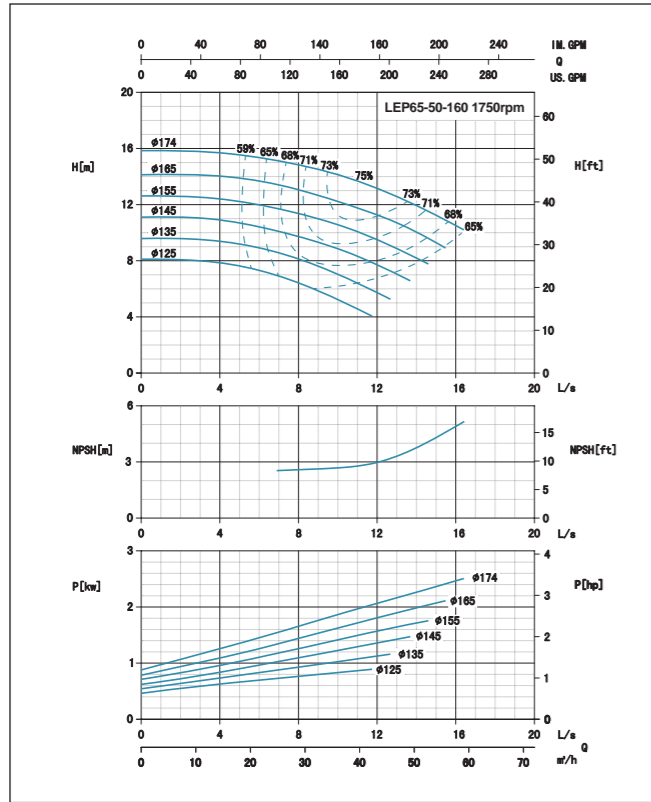

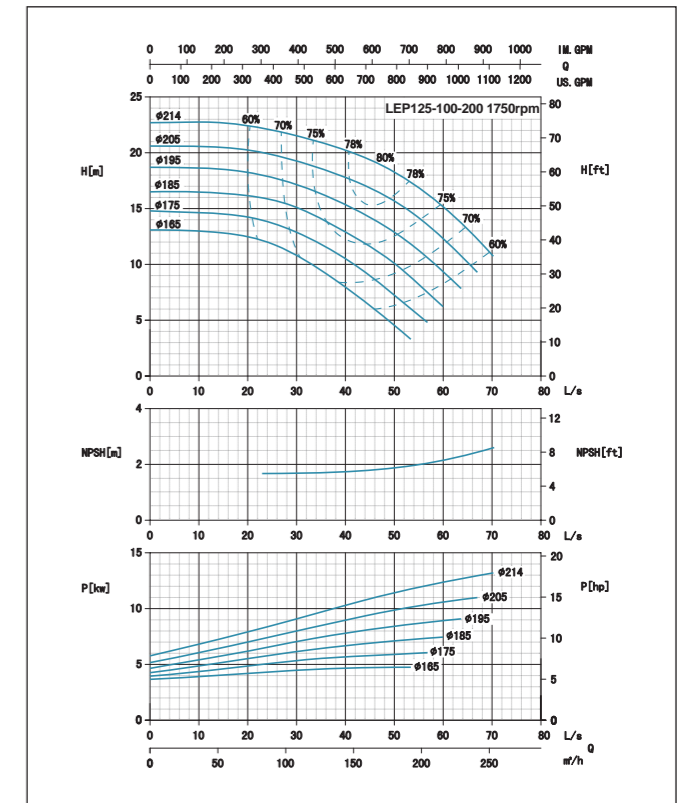
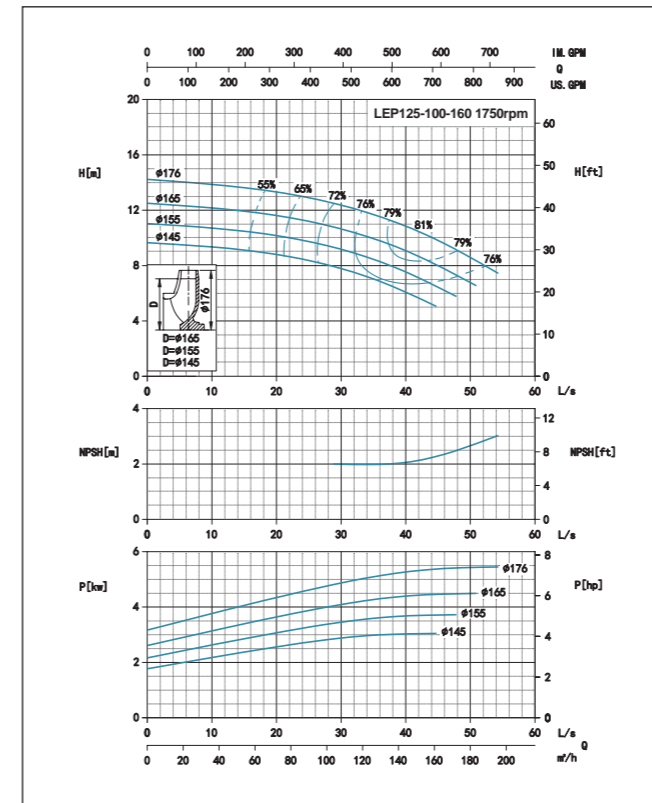
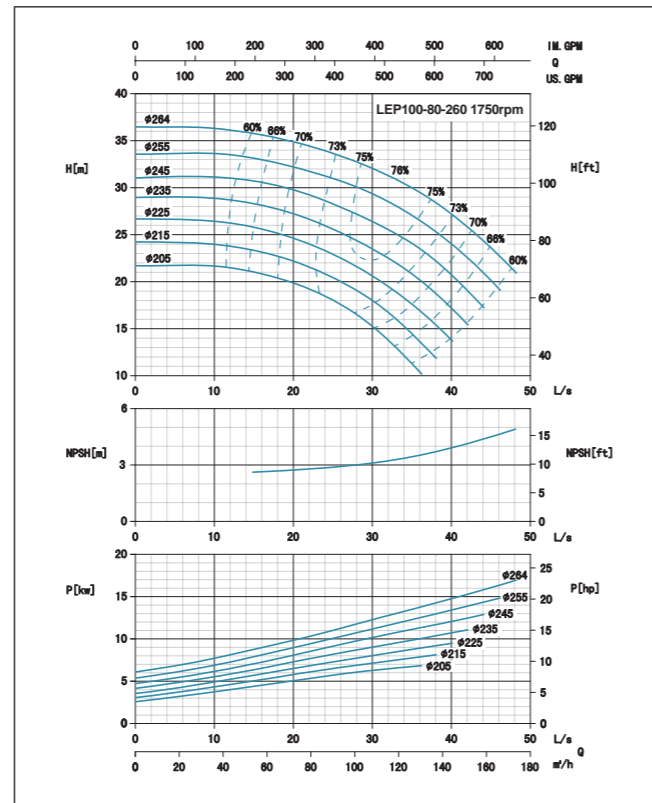
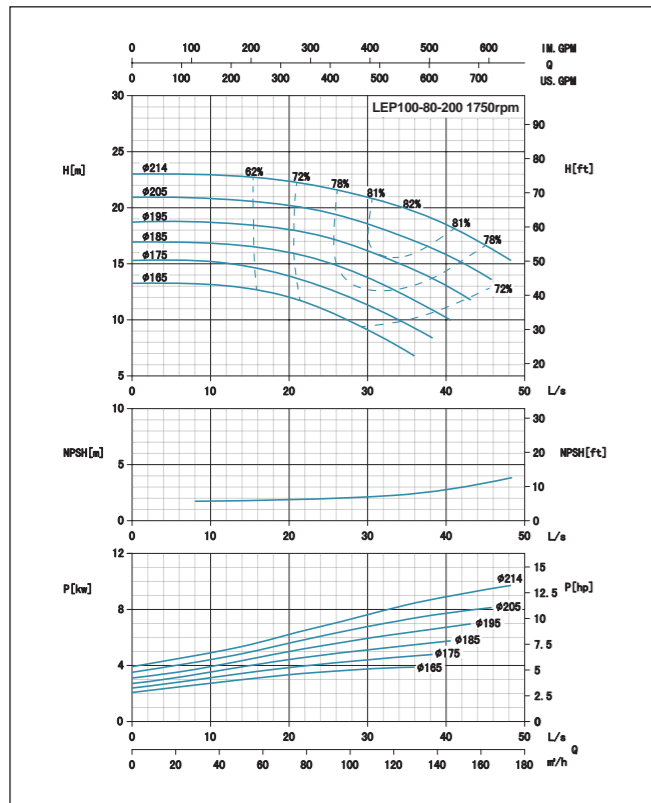
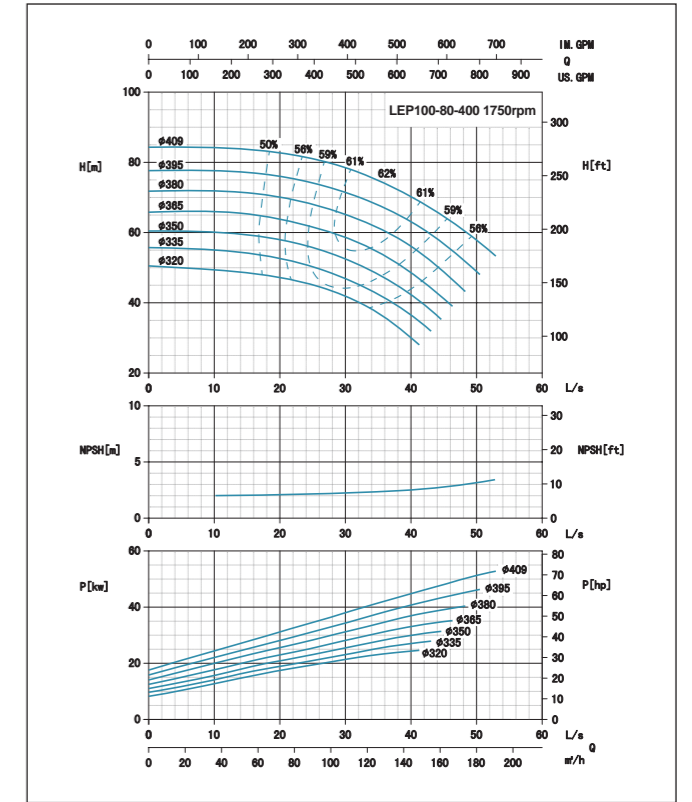
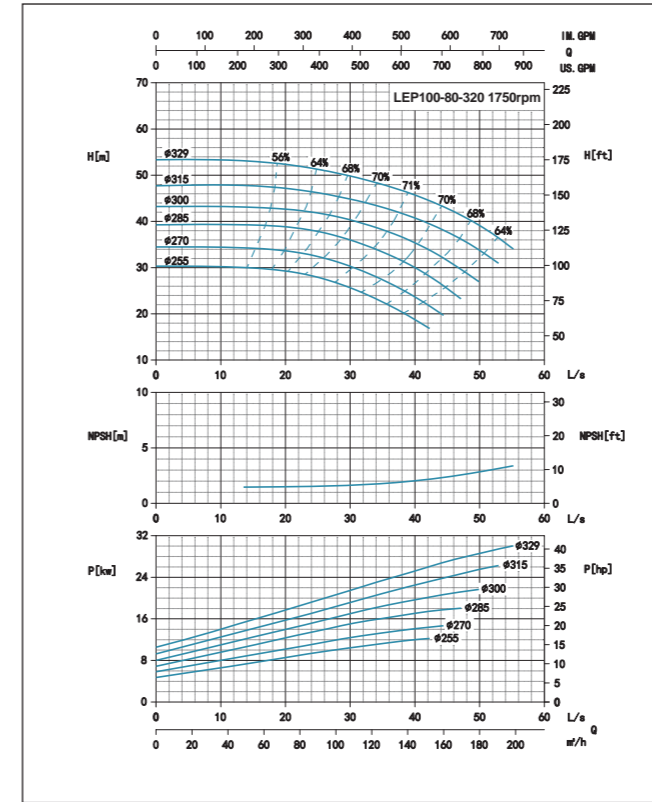
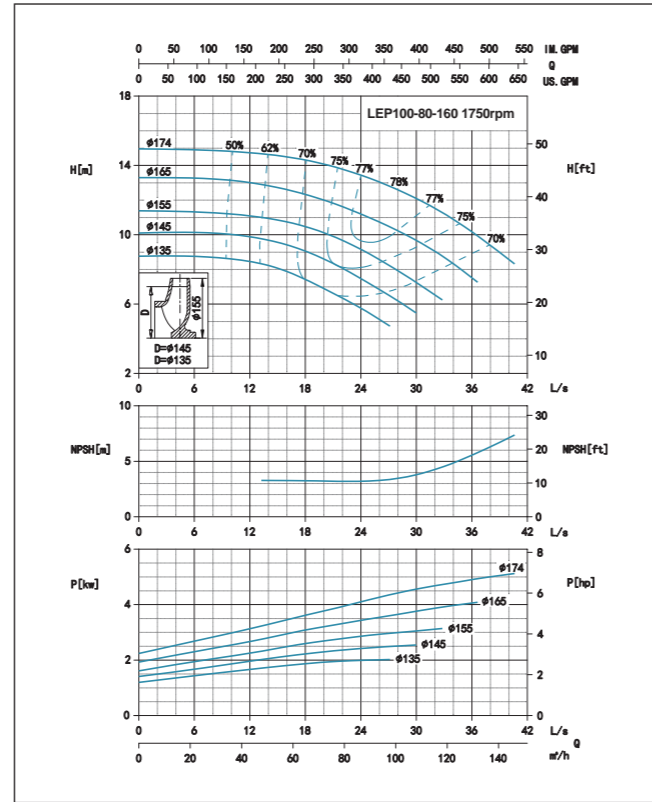
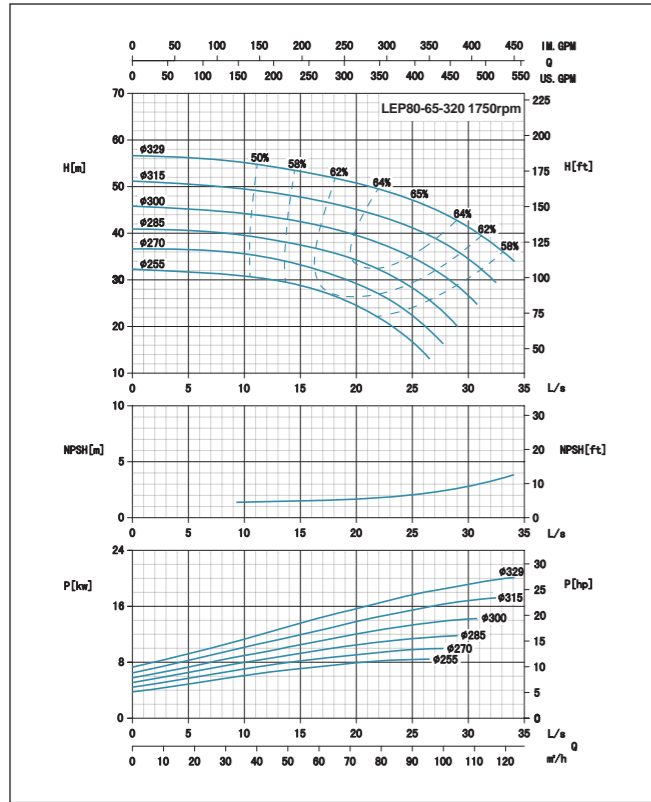

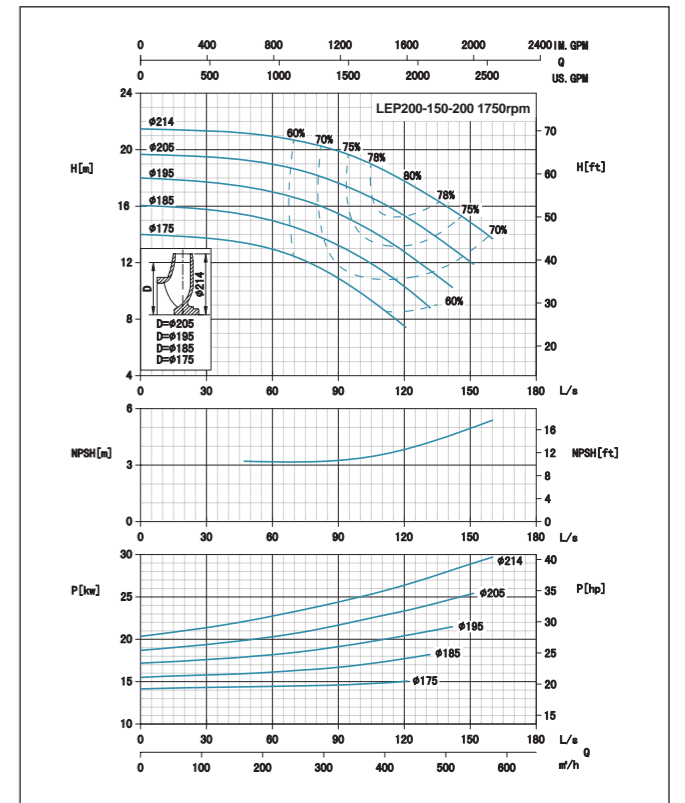
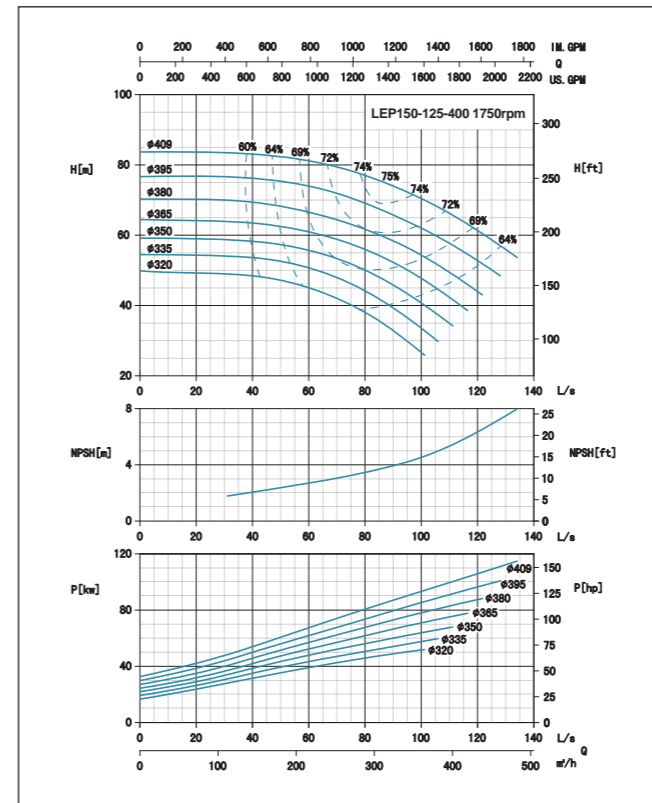
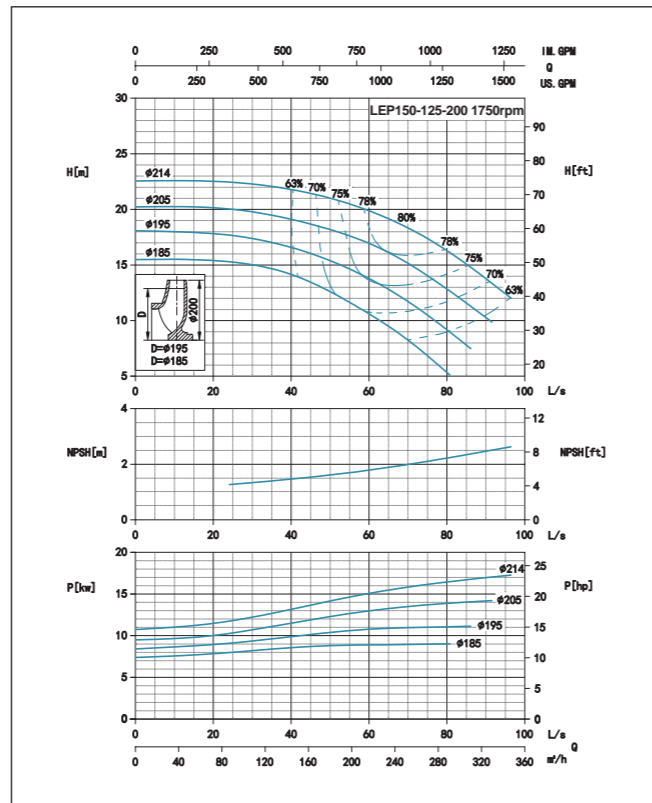
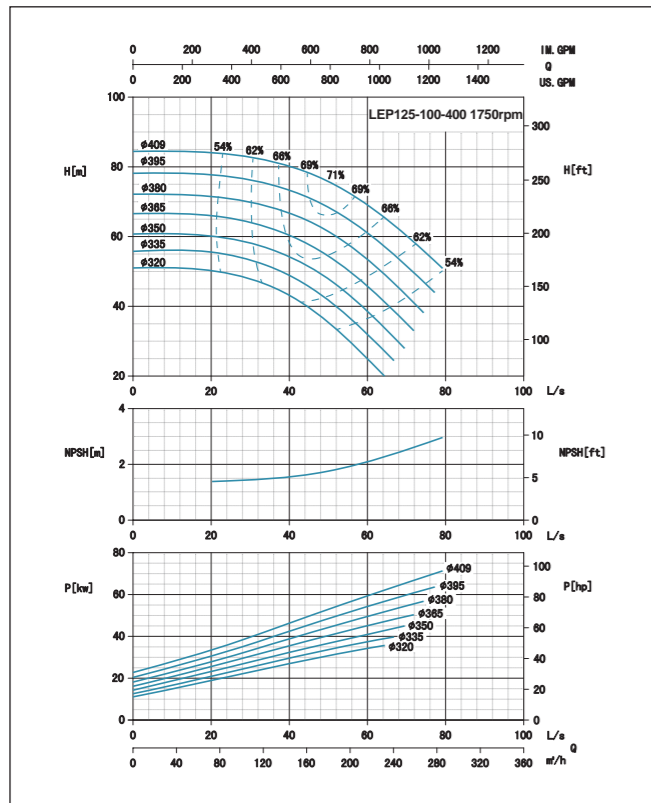
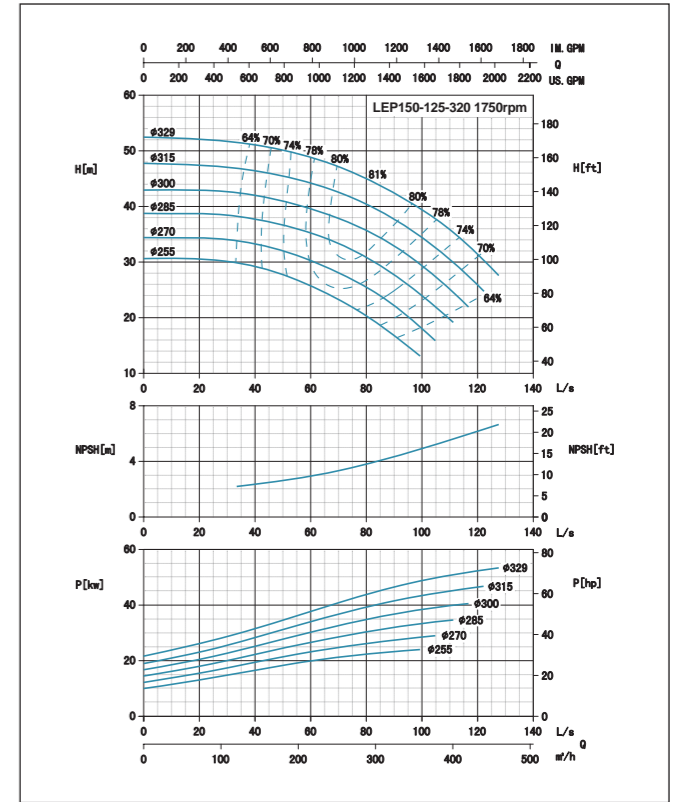
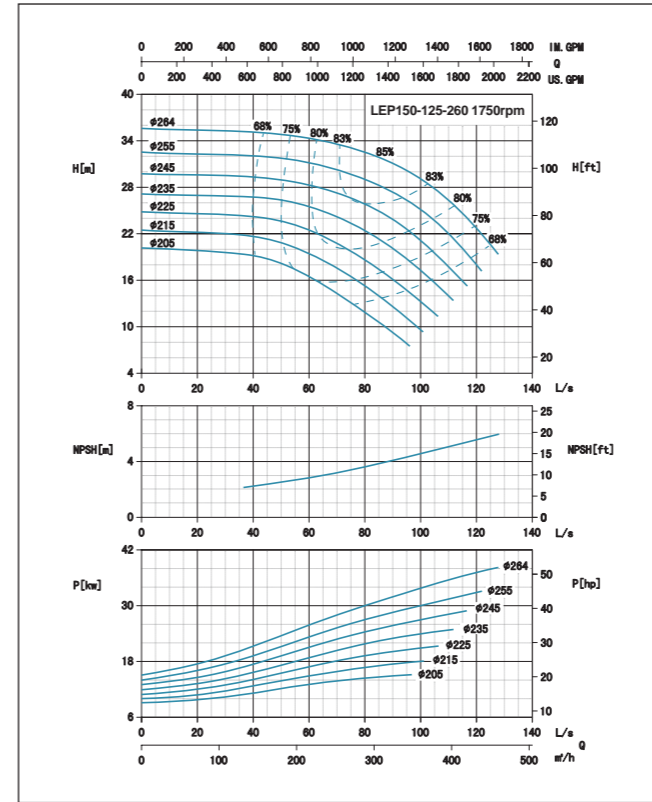
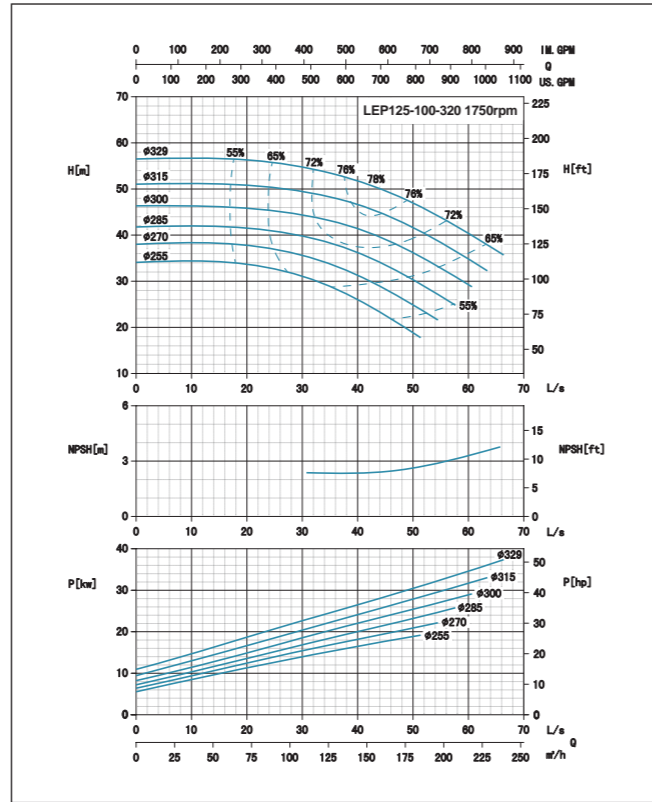
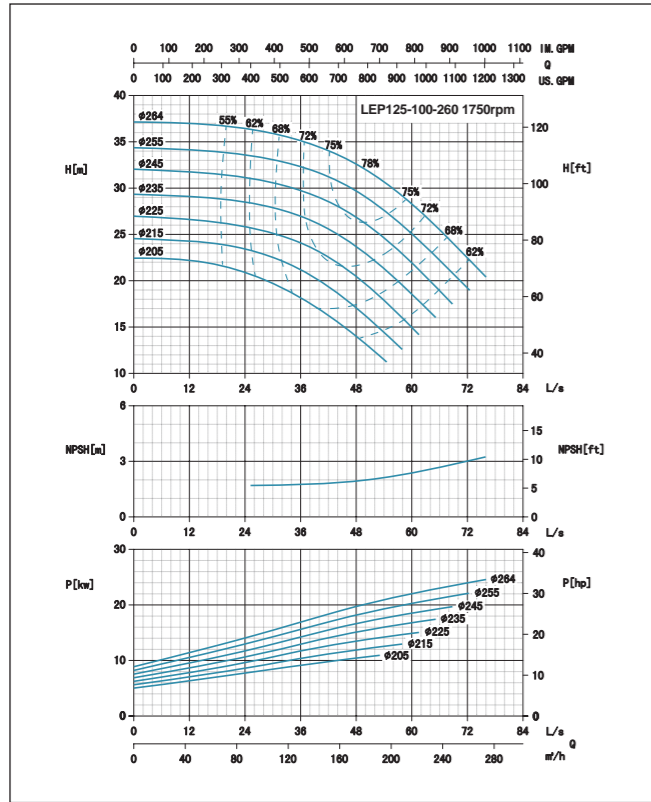

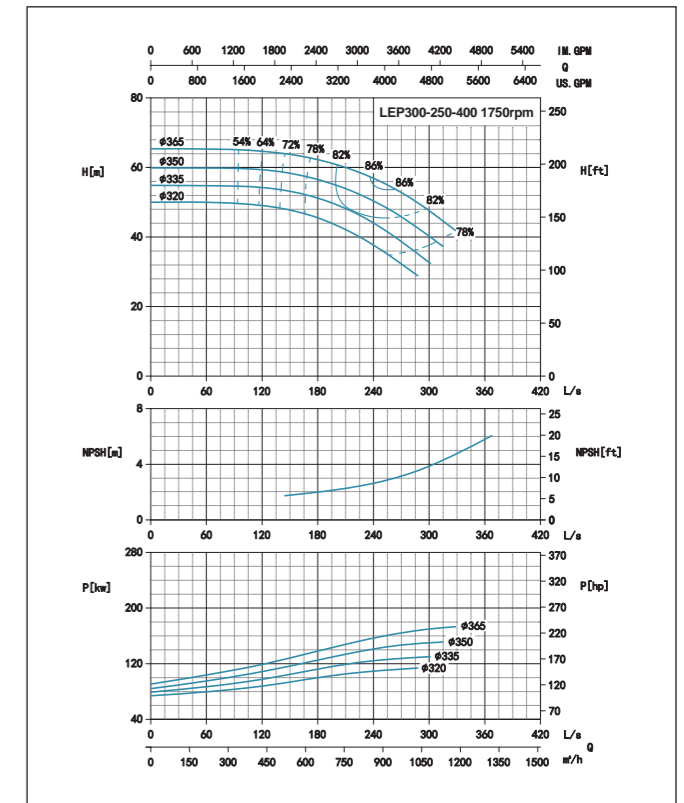
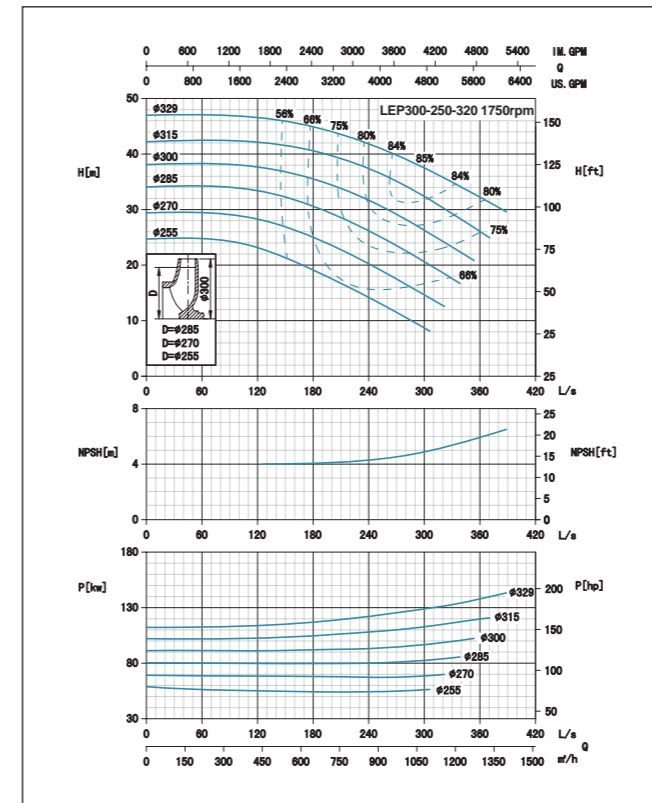
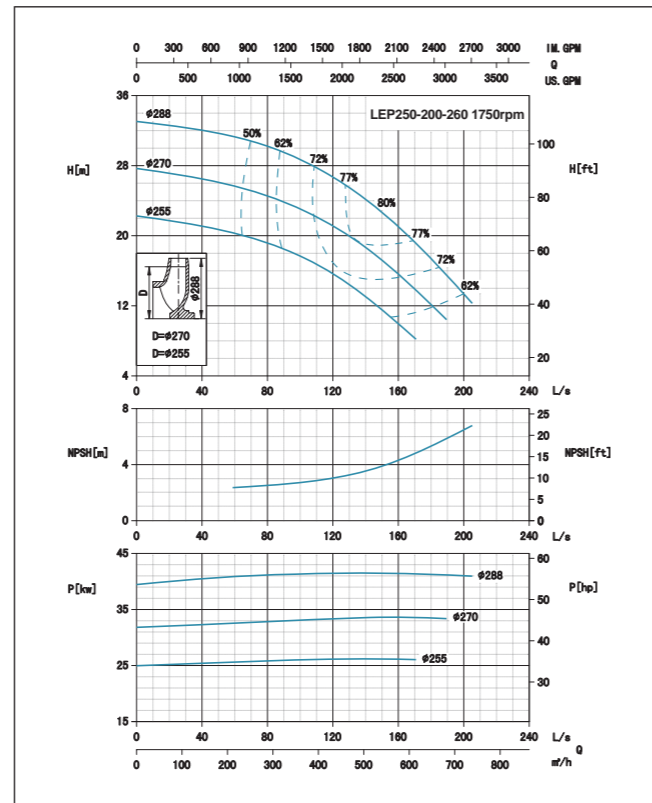
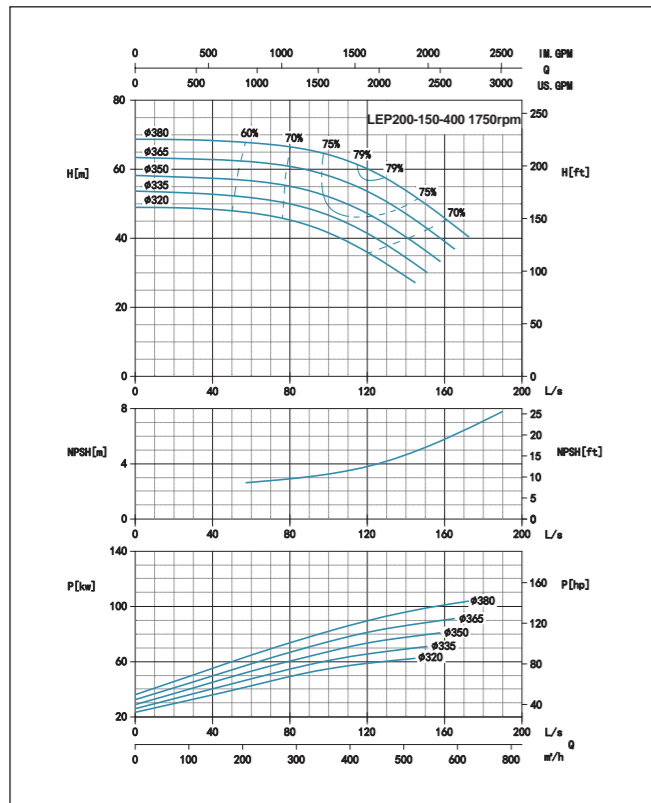
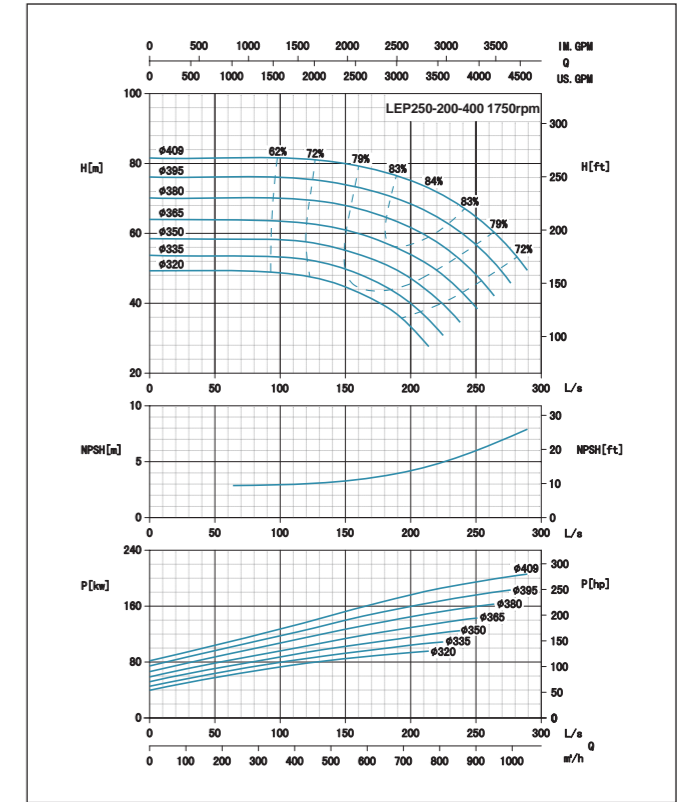
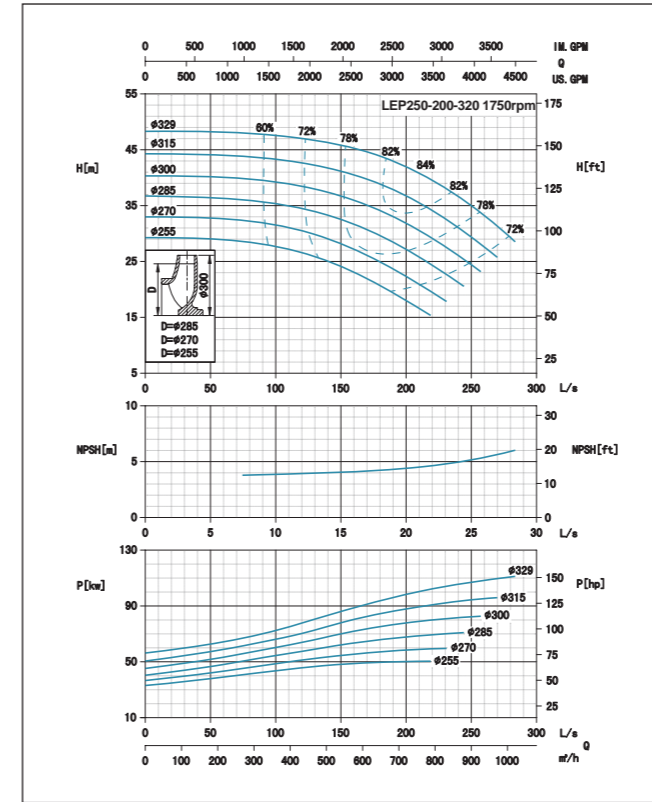
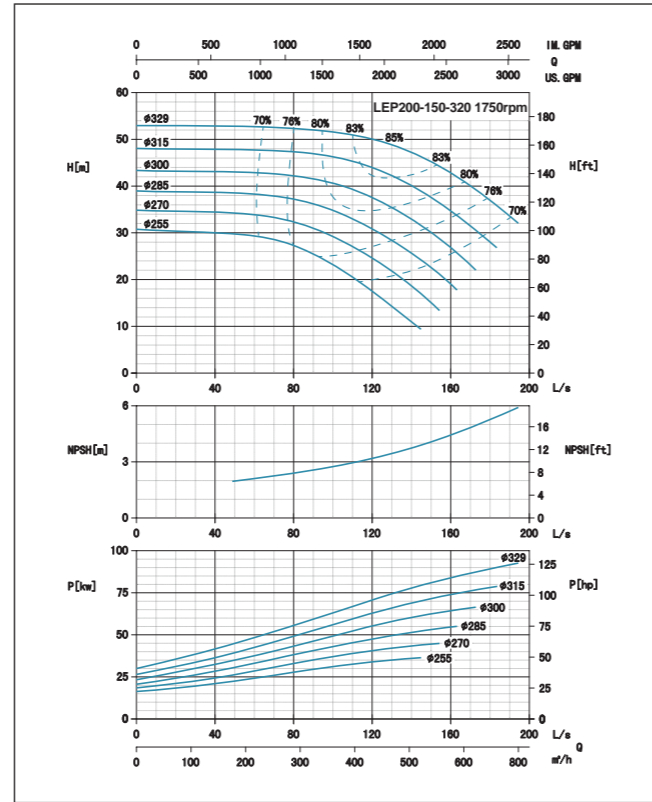
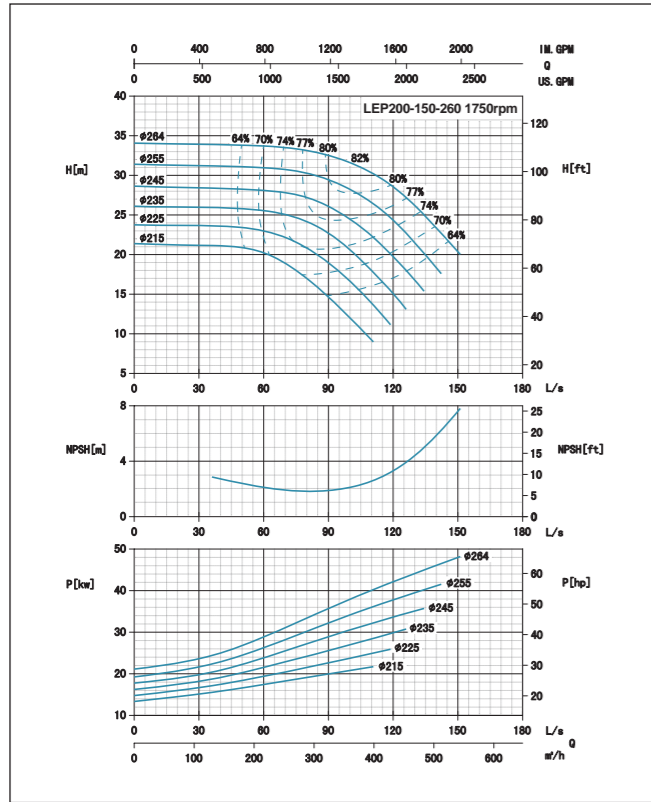

Pump Range



● Peripheral Pump



● Self-Priming Peripheral Pump

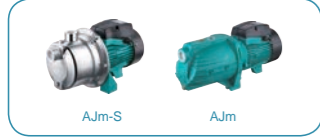

● Jet Pump



● Jet Pump for Deep Wells



● Centrifugal Pump



● Multistage Centrifugal Pump



● Self-Priming Centrifugal Pump

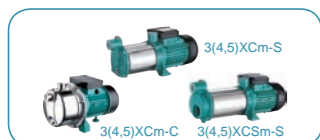

● Stainless Steel Multistage Centrifugal Pump



● Stainless Steel Centrifugal Pump



● Submersible Pump



● Stainless Steel Submersible Pump



● Stainless Steel Submersible Sewage Pump



● Flexible Shaft Pump



● Domestic Lifting Station



● Pool Pump



● Garden Submersible Pump



● Garden Jet Pump



● Pressure Booster System



● Fountain Pump



● Standard Centrifugal Pump



● Submersible Borehole Pump



● Gasoline/Diesel Engine Pump



● Booster Pump/Circulation Pump

Pump Range



● Submersible Sewage Pump



● Submersible Sewage Pump



● Submersible Dewatering Pump



● Submersible Slurry Pump



● Stainless Steel Vertical Multistage Pump



● Stainless Steel Horizontal Multistage Pump



● Semi-open Impeller Stainless Steel Centrifugal Pump



● Stainless Steel Standard Centrifugal Pump



● Pressure Booster System



● Vertical In-line Pump



● Bare Shaft End Suction Centrifugal Pump



● End Suction Centrifugal Pump