

FM
Frame Mount

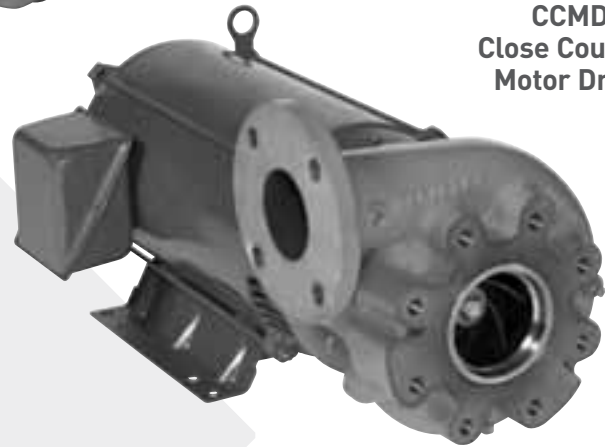

CCMD
Close Coupled
Motor Drive

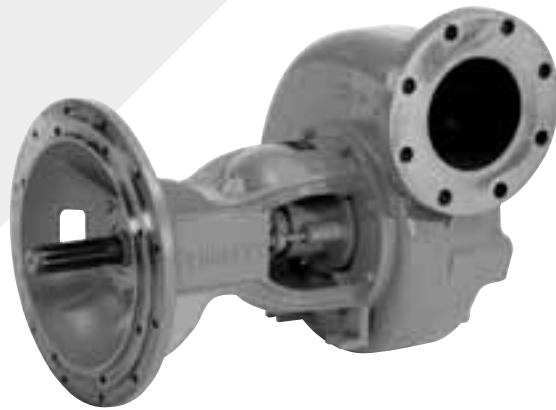

Engine Drive
SAE

BERKELEY[®] TYPE B CENTRIFUGAL PUMPS PUMP PERFORMANCE

PUMP MODEL NOMENCLATURE

NAME PLATE EXAMPLE:

B 4 G P B H S

- B** – TYPE OF CONSTRUCTION
B = "Back Pull-Out" Design
- 4** – DISCHARGE SIZE (Inches)
NOMINAL IMPELLER DIAMETER (Inches)
- G** – 3" = A 7" = W 11" = F 15" = EX 18" = EY
4" = M 8" = Y 12" = G 15.5" = XT 19" = EZ
5" = X 9" = Z 13" = J 16" = ET 20" = EE
6" = T 10" = E 14" = N 17" = EW
- P** – TYPE OF DRIVE
P = Electric Motor – Pump Attached Directly to Motor Frame
Q = Engine Drive – Pump Attached Directly to Engine Frame
R = Frame Mounted Belt or Flexible Coupling Drive
RM = Special Duty Mounting Frame
- B** – SPECIAL FEATURES (Optional)
B = Hydraulically Balanced Impeller Design
K = Self-Priming
- H** – RELATIVE CAPACITY OF IMPELLER
LL = Very Low
L = Low
M = Medium (Often Omitted)
H = High
HH = Very High
- 2** – NUMBER OF STAGES (Optional)
(Single stages not indicated)
- S** – SHAFT SEAL (Optional)
S = Mechanical Seal (Packed Stuffing Box is not indicated)
- 10** – HORSEPOWER OF MOTOR OR ENGINE (Optional)
(Normally indicated on Engine Driven Pumps only)

The model configurations above illustrate the complete range of closed coupled product identification numbers.

PUMP SIZE EXAMPLE:

4" x 6" x 13" B H

- 4"** – DISCHARGE SIZE (Inches)
- 6"** – SUCTION SIZE (Inches)
- 13"** – NOMINAL IMPELLER DIAMETER (Inches)
3" = A 7" = W 11" = F 15" = EX 18" = EY
4" = M 8" = Y 12" = G 15.5" = XT 19" = EZ
5" = X 9" = Z 13" = J 16" = ET 20" = EE
6" = T 10" = E 14" = N 17" = EW
- B** – SPECIAL FEATURES (Optional)
B = Hydraulically Balanced Impeller Design
- H** – RELATIVE CAPACITY OF IMPELLER
LL = Very Low
L = Low
M = Medium (Often Omitted)
H = High
HH = Very High

Berkeley Type B Hydraulic Performance (by product group)

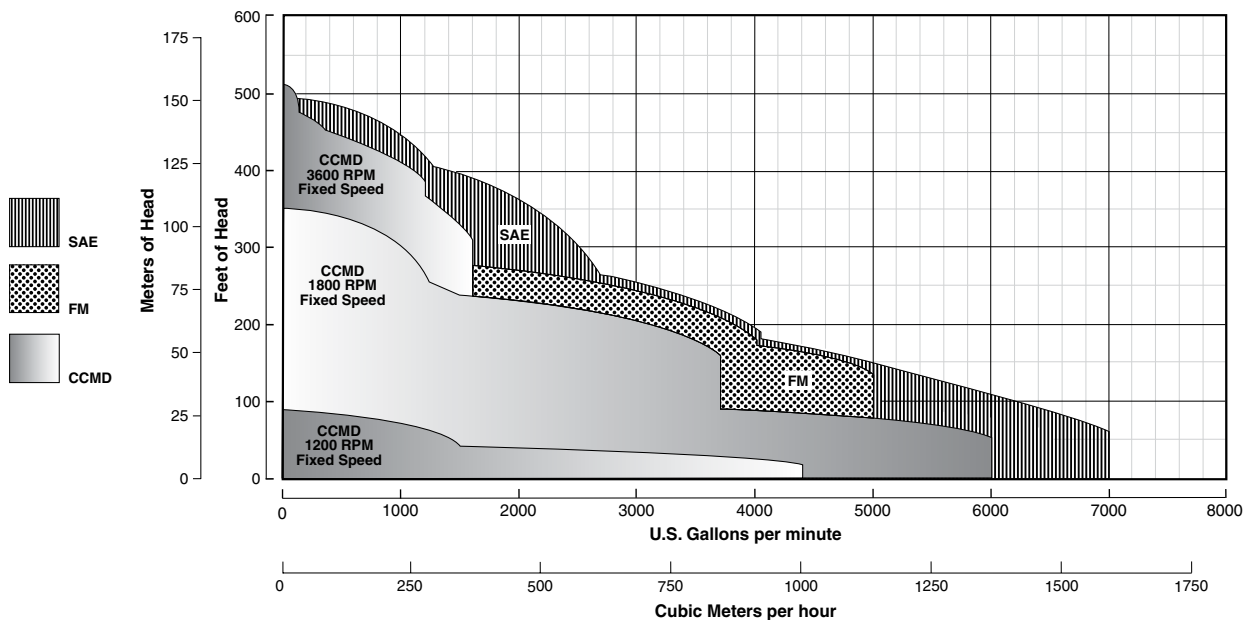

Pump Size: 4 x 5 x 13 BH

Model: B4J_BH

Curve No. 9013

Type	CCMD	FM CPLG	FM BELT	SAE	Hydraulic	AC Engine
Model	B4JPBH	B4JRMBH	B4JRMBH	B4JQBH		

Nominal RPM: **1750**
 Based on Fresh Water @ **68°F (20°C)**
 Maximum Working Pressure: **266 PSI (18 BAR)**

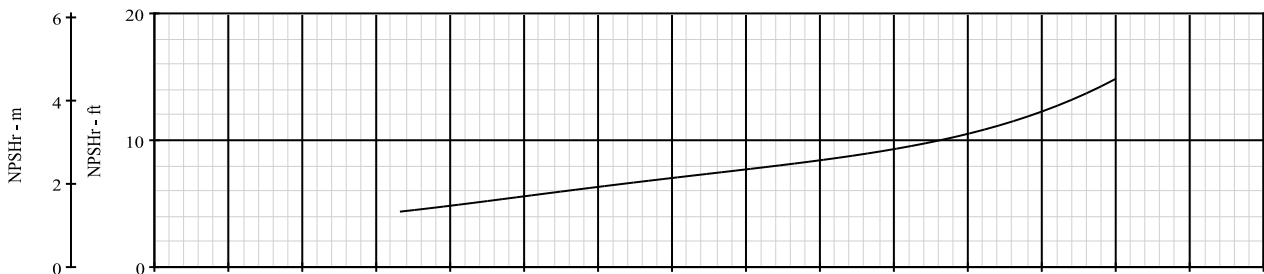
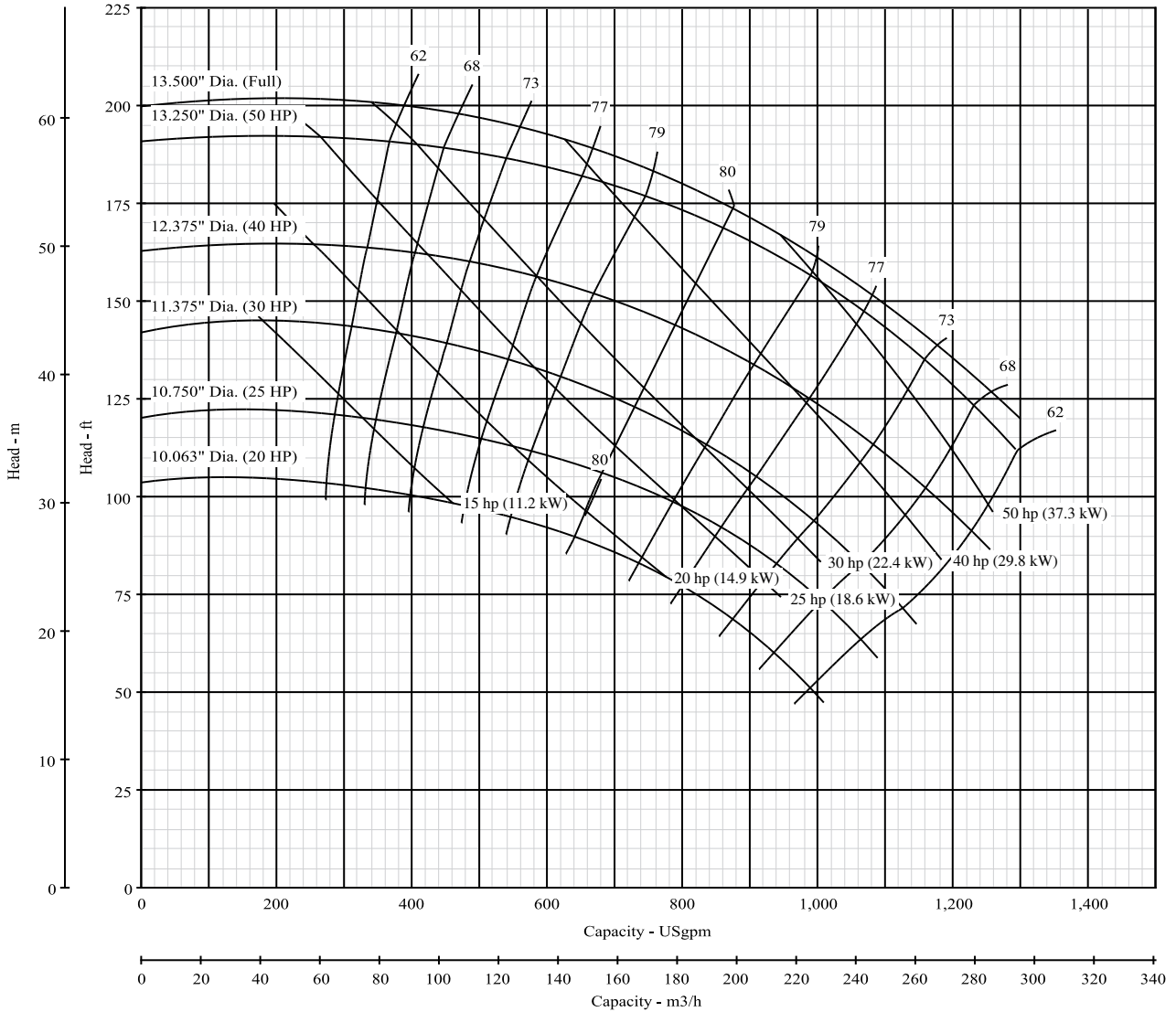

Pump Size: 4 x 5 x 13 BH

Model: B4J_BH

Curve No. 9013

Type	CCMD	FM CPLG	FM BELT	SAE	Hydraulic	AC Engine
Model	B4JPBH	B4JRMBH	B4JRMBH	B4JQBH	B4JRMBH	
RPM	1201-1800	1400-2400	1400-2200	1400-2400	1400-2400	

Dia. 13.50"

Nominal RPM: **VARIOUS**
 Based on Fresh Water @ 68°F (20°C)
 Maximum Working Pressure: 266 PSI (18 BAR)

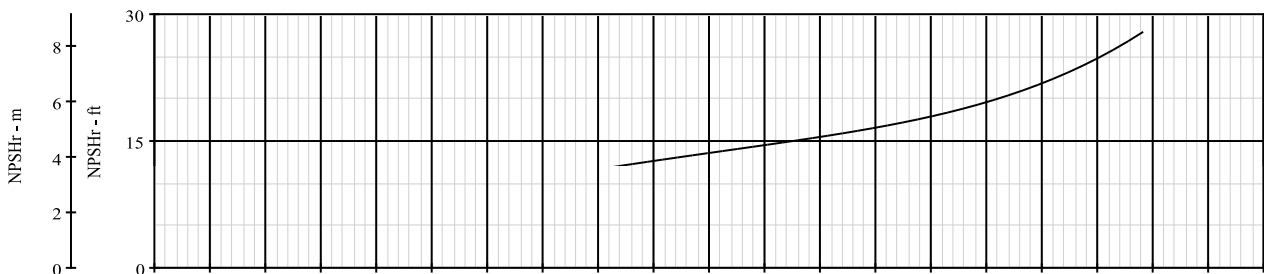
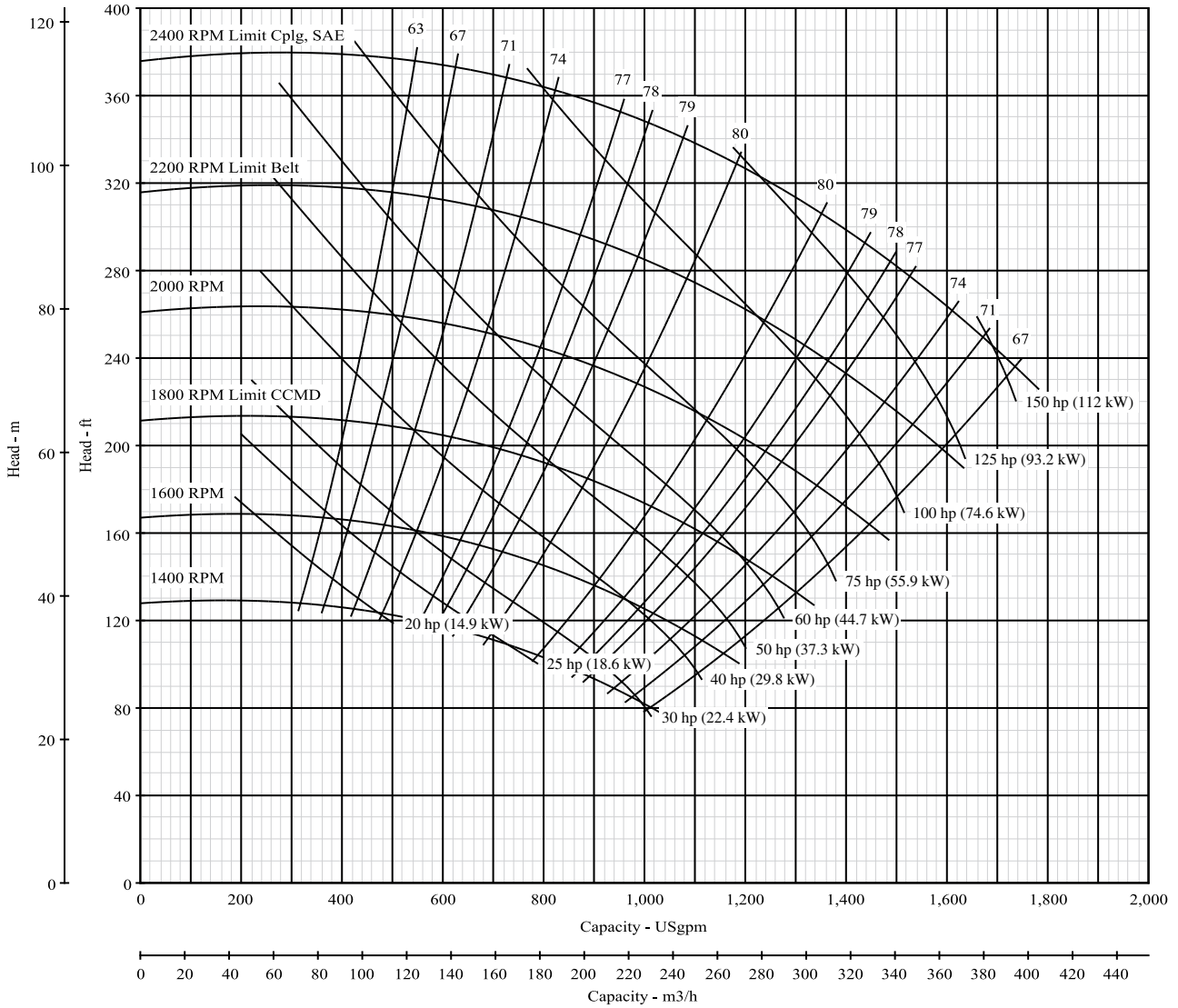

*NPSH data shown is at maximum speed