



KTV(E)- SERIES
SEMI-VORTEX - DEWATERING PUMP (Auto Type)

SPECIFICATIONS

■ FEATURES

1. Semi-vortex, urethane rubber, Ductile Iron, or High Chrome Cast Iron impeller with synthetic rubber casing increases wear resistance when pumpage contains abrasive particles.
2. Double inside mechanical seals with silicon carbide faces, running in an oil filled chamber and further protected by a lip seal running against a replaceable, 430 stainless steel shaft sleeve, provides for the most durable seal design Available.
3. Highly efficient, continuous duty, air filled, copper wound motor with class E insulation minimizes the cost of operation.
4. Double shielded, permanently lubricated, high temperature C3 ball bearings rated for a

B-10 life of 60,000 hours extend operational life.

5. Top discharge, flow-thru design enables operation at low water levels for extended Periods.
6. Automatic Operation on KTVE Series.
7. A powerful Slurry pump series using KTV2-50/-80 pumps as a base incorporates high chrome cast iron agitator.

■ APPLICATIONS

1. Commercial, industrial wastewater and construction site drainage.
2. Effluent transfer.
3. Decorative waterfalls and fountains.
4. Raw water supply from rivers or lakes.



■ SPECIFICATIONS

- Discharge Size
- Horsepower Range
- Performance Range Capacity Head
- Maximum water temperature
- Materials of Construction
 - Casing
 - Impeller
 - Agitator
 - Shaft
 - Motor Frame
 - Fasteners
- Mechanical Seal Elastomers
- Impeller Type
- Solids Handling Capability
- Motor Nomenclature
 - Type, Speed, Hz.
 - Voltage, Phase
 - Insulation
 - Bearings
- Accessories
- Operational Mode

■ STANDARD

- 2 - 3" NPT (50 - 80 mm)
- 1 ~ 7.5 HP. (0.75 ~ 5.5 Kw)
- 23.8 ~ 230.0 GPM. (0.09 ~ 0.87 m³/min)
- 16.4 ~ 121.0 Ft. (5.0 ~ 36.9 m)
- 104° F. (40° C.)
- Butadiene Rubber + Natural Rubber
- Urethane Rubber , Ductile Cast Iron , High Chrome Cast Iron(KTV2-50/-80)
- High Chrome Cast Iron(KTV2-50/-80)
- 403/420 Stainless Steel
- Aluminum alloy
- 304 Stainless Steel
- Silicon Carbide
- NBR (Nitrile Butadiene Rubber)
- Semi-vortex, solids handling.
- 0.334" (8.5mm)
- Air Filled, 3600 RPM, 60 Hz.
- 208/230/460/575 V., 3 Phase
- Class E
- Pre-lubricated, Double Shielded
- Submersible Power Cable 50' (15 m)
- Manual , Automatic (KTVE)

■ OPTIONS

Length as Required



TSURUMI PUMP

KTV - SERIES
SEMI-VORTEX - DEWATERING & AGITATOR PUMPS

PERFORMANCE RANGE

GROUP PERFORMANCE RANGE

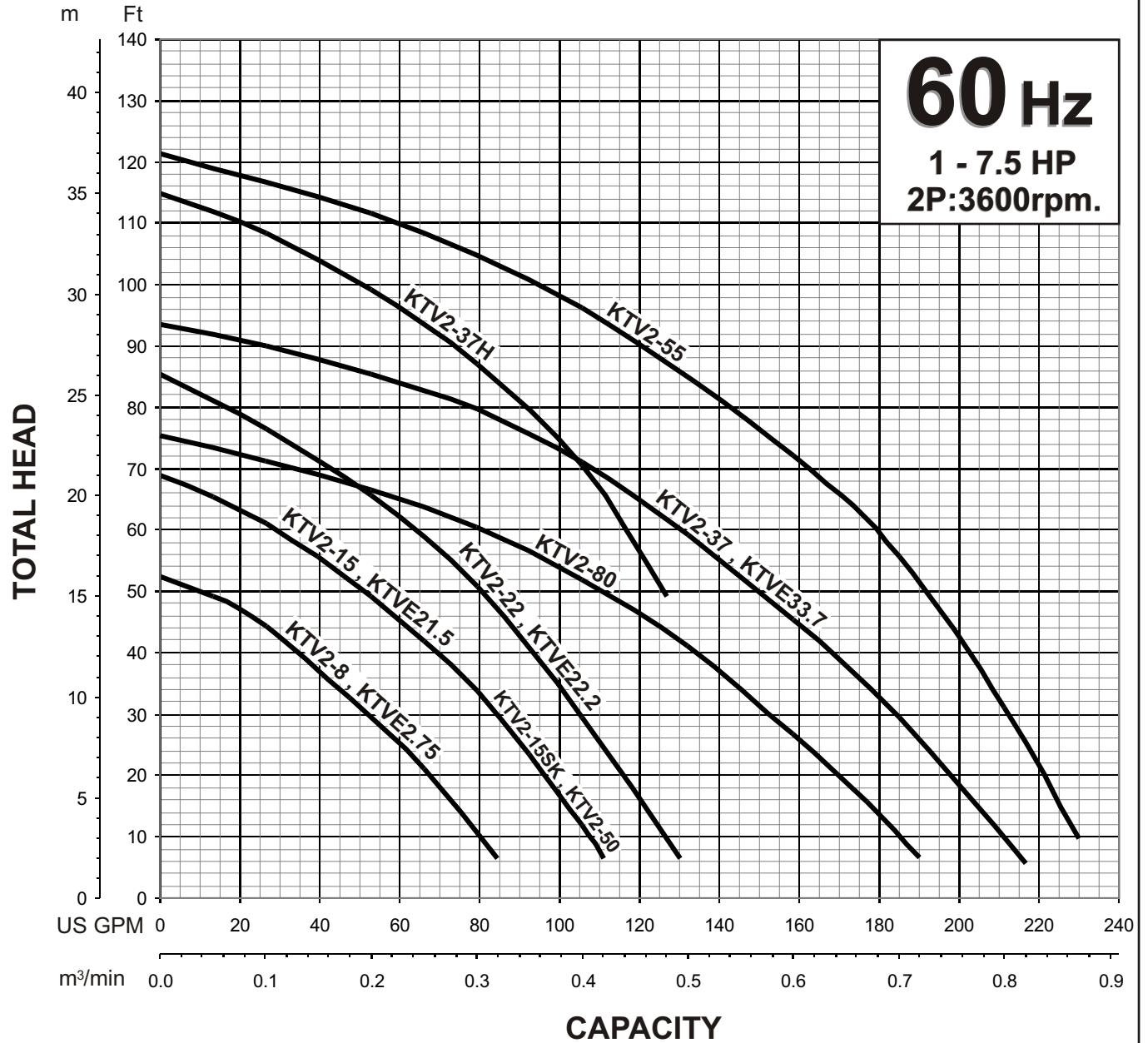

	Standard	High Torque
Model	KTV2-15SK 2HP(1.5kW)	KTV2-50 2.7HP(2.0kW)
High Torque model further suitable for heavy duty application.		



KTVE - SERIES SEMI-VORTEX - DEWATERING PUMPS (AUTO TYPE)

PERFORMANCE CURVE

MODEL	BORE	HP	KW	RPM	SOLIDS DIA	LIQUID	SG.	VISCOSITY	TEMP.
KTVE2.75-60	2"/50mm	1	0.75	3320	0.334"/8.5mm	Water	1.0	1.123 cSt.	60°F
PUMP TYPE		PHASE	VOLTAGE	AMPERAGE		HZ	STARTING METHOD		INS. CLASS
Semi-Vortex - Dewatering Pump		3	208-220 / 440 / 575	3.4-3.2 / 1.7 / 1.3		60	Direct On Line		E
CURVE No.	DATE	PHASE	VOLTAGE	AMPERAGE		HZ	STARTING METHOD		INS. CLASS
-	-	-	-	-		-	-		-

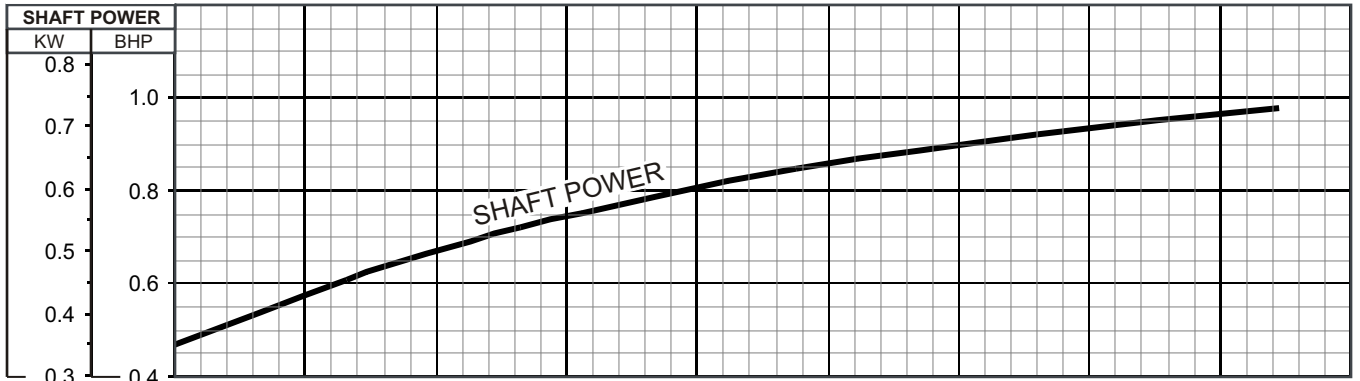
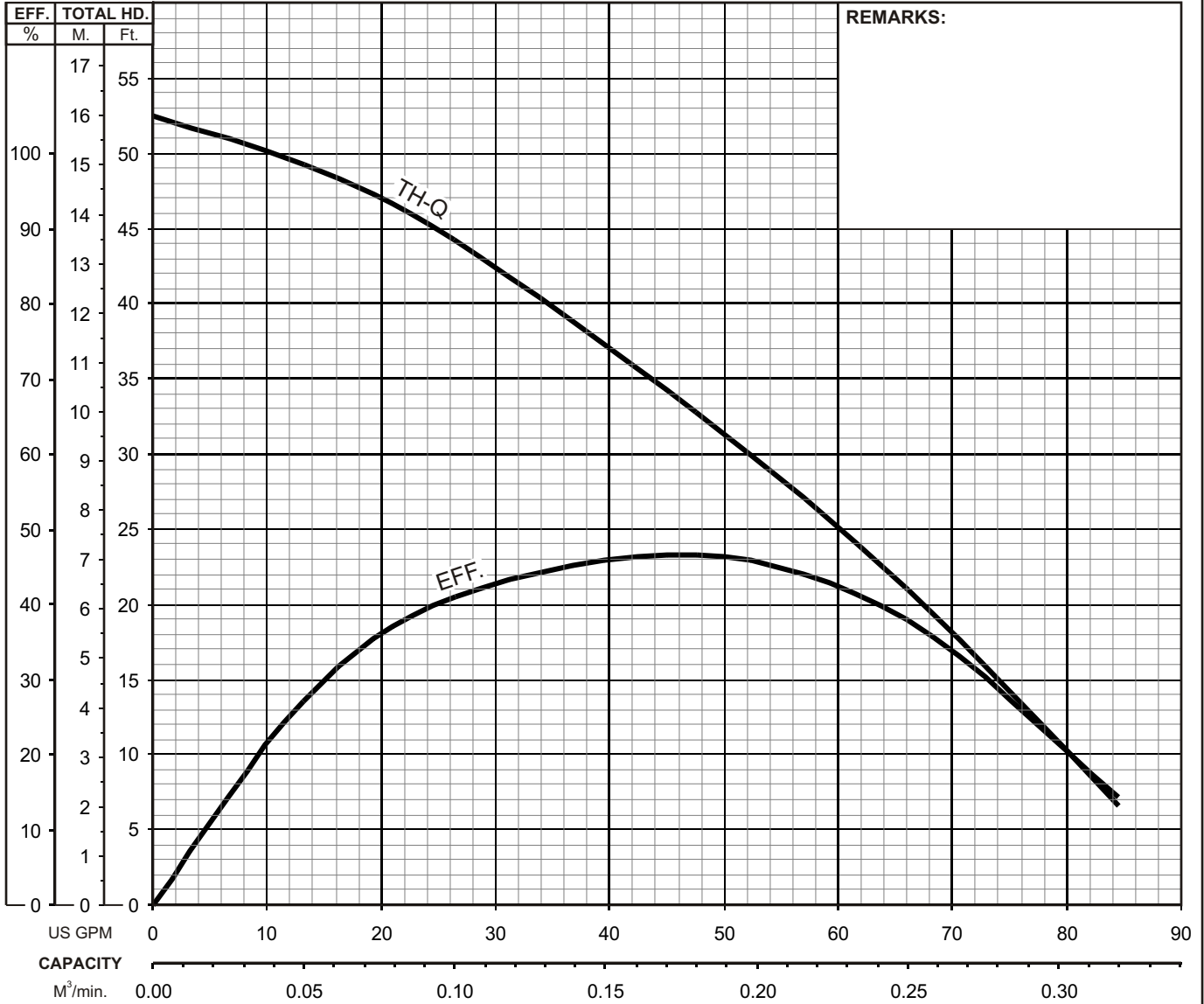

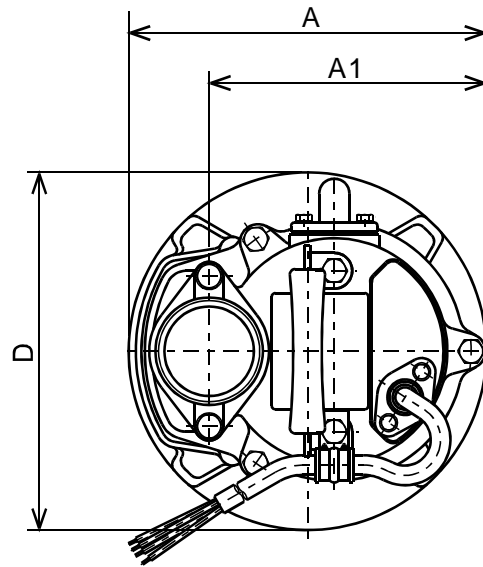
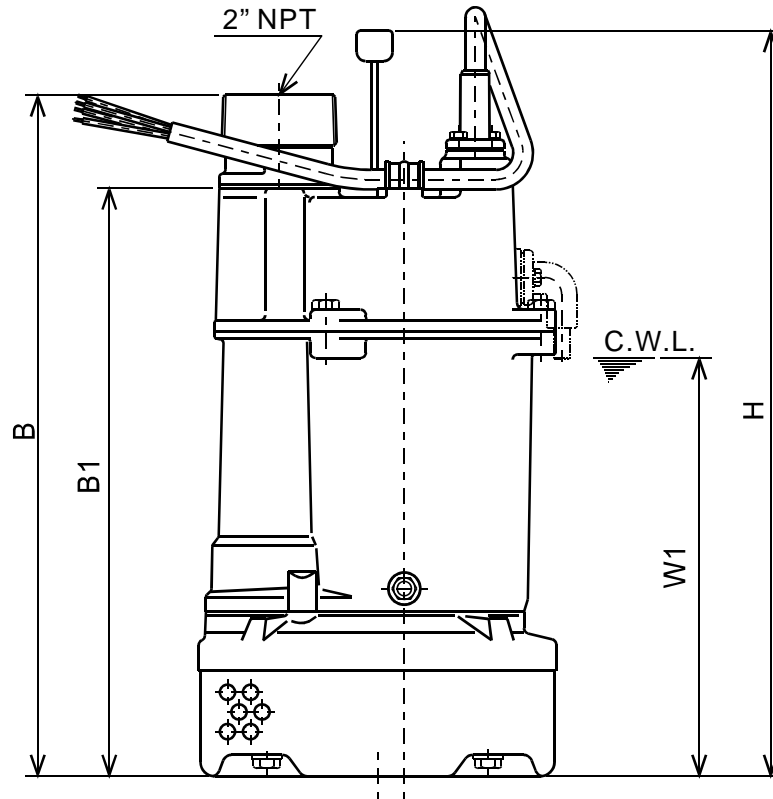
**TSURUMI PUMP**
KTVE - SERIES
SEMI-VORTEX - DEWATERING PUMPS (AUTO TYPE)
DIMENSIONS**KTVE2.75-60**

C.W.L. : Continuous running Water Level

DIMENSIONS:USCS (Inch)

Model	HP	NOM. SIZE	Pump & Motor						C.W.L.	Wt. (lbs.)
			A	A1	B	B1	D	H	W1	
KTVE2.75-60	1	2"	7 7/8	6 1/8	15	12 15/16	7 7/8	16 7/16	9 1/4	28

DIMENSIONS:METRIC (mm)

Model	kW	NOM. SIZE	Pump & Motor						C.W.L.	Wt. (kg)
			A	A1	B	B1	D	H	W1	
KTVE2.75-60	0.75	50	200	155	381	329	200	417	234	12.7



TSURUMI PUMP

KTVE - SERIES
SEMI-VORTEX - DEWATERING PUMPS (AUTO TYPE)

SECTIONAL VIEW

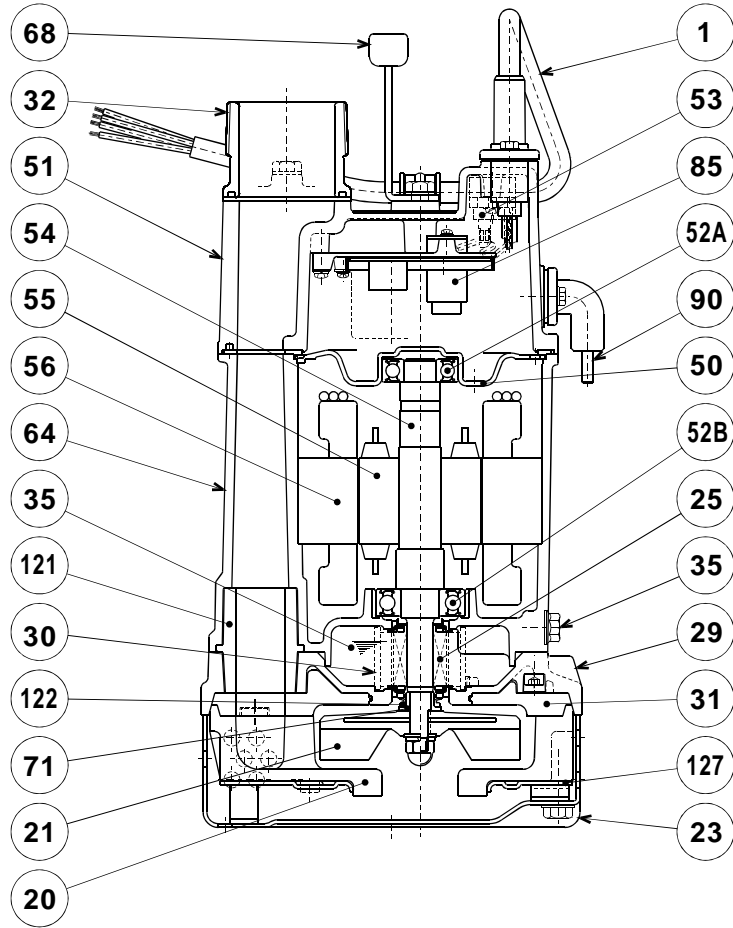

KTVE2.75-60

ITEM#	DESCRIPTION	MAIN MATERIAL / NOTE	ASTM, AISI CODE	RELATED EN CODE	Q'TY
1	Power Cable	PVC Sheath AWG16/4-50ft			1
20	Pump Casing	Butadiene Rubber + Natural Rubber			1
21	Impeller	Urethane Rubber			1
23	Suction Strainer	Steel (Cold Rolled)	A109/A1008	EN 10130	1
25	Mechanical Seal	Silicon Carbide / W-14VL			1
29	Oil Casing	Aluminum Alloy Die Casting	B85 A383,0	EN1706 AC-46100	1
30	Oil Lifter	PA Resin			1
31	Wear Ring	Butadiene Rubber + Natural Rubber			1
32	Discharge Connection	Cast Iron / NPT 2"	A48 Class 35	EN1561 GJL-250	1
35	Oil Plug	Stainless Steel	S 30400	1.4301	1
36	Lubricant	Turbine Oil ISO VG32 or SAE10W-20			
50	Motor Bracket	Steel (Hot Rolled)	A1011	EN 10111	1
51	Motor Head Cover	Aluminum Alloy Die Casting	B85 383.0	EN1706 AC-46100	1
52A	Upper Bearing	#6203ZZC3			1
52B	Lower Bearing	#6204ZZC3			1
53	Motor Protector				1
54	Shaft	Stainless Steel	S 42000	1.4028	1
55	Rotor				1
56	Stator				1
64	Motor Housing	Aluminum Alloy Die Casting	B85 A383,0	EN1706 AC-46100	1
68	Handle	Steel (Cold Rolled) + Nitrile Butadiene Rubber	A109/A1008	EN 10130	1
71	Shaft Sleeve	Stainless Steel	S 30400	1.4301	1
85	Relay Unit				1
90	Level Sensor (Electrode)	Stainless Steel + Chloroprene Rubber	S 30400	1.4301	1
121	Duct Sleeve	Styrene Butadiene Rubber			1
122	V-Ring	Nitrile Butadiene Rubber			1
127	Fixing Plate	Carbon Steel	A109/A1008	EN 10130	1

TSURUMI PUMP
**KTV - SERIES
SEMI-VORTEX - DEWATERING PUMPS**
**SAMPLE
SPECIFICATIONS**

1. SCOPE OF SUPPLY -

Furnish and install TSURUMI Model _____ Submersible Pump(s).
Each unit shall be capable of delivering _____ GPM (_____ m³/min) at _____ Feet (_____ m) TDH. The pump(s) shall be designed to pump waste water, without damage during operation. The pump(s) shall be designed so that the shaft power required (BHP)/(kW) shall not exceed the motor rated output throughout the entire operating range of the pump performance curve. Pump(s) shall be of the top discharge, flow through design.

2. MATERIALS OF CONSTRUCTION -

Construction of major parts of the pumping unit(s) shall be as follows: Pump casing shall be synthetic rubber. Motor frame shall be aluminum alloy die casting. Internal and external surfaces coming into contact with the pumpage shall be protected by a fused polymer coating. All exposed fasteners shall be stainless steel. All units shall be furnished with _____" NPT discharge connector. Impellers shall be of the multi-vane, ductile cast iron or urethane rubber (1Hp), semi-vortex design, equipped with back pump out vanes and shall be slip fit to the shaft and key driven.

3. MECHANICAL SEAL -

All units shall be furnished with a dual inside mechanical shaft seal located completely out of the pumpage, running in a separate oil filled chamber and further protected by an exclusionary oil seal located between the bottom seal faces and the fluid being pumped. The oil chamber shall be fitted with a device that shall provide positive lubrication of the top mechanical seal, (down to one third of the standard oil level). The device shall not consume any additional electrical power. Mechanical seals shall be rated to preclude the incursion of water up to 42.6 PSI. (98.4 Ft.) submergence. Units shall have silicon carbide mechanical seal faces. Mechanical seal hardware shall be stainless steel.

4. MOTOR-

The pump motor(s) shall be _____ HP., _____ kW., _____ V., 60 Hz. 3 Phase and shall be NEMA MG-1 Design Type B equivalent. Motor(s) shall be rated at _____ full load amps. Motor(s) shall have a 1.15 service factor and shall be rated for 20 starts per hour. Motor(s) shall be air filled, copper wound, class E insulated with built in thermal and over amperage protection for each winding. Motor shaft shall be 403 or 420 stainless steel, fitted with a replaceable stainless steel shaft sleeve and shall be supported by two permanently lubricated, high temperature ball bearings, with a B-10 life rating at best efficiency point of 60,000 hours. Bearings on all units shall be single row, double shielded, C3, deep groove type ball bearing. Motors shall be suitable for across the line start or variable speed applications, utilizing a properly sized variable frequency drive.

5. POWER CABLE AND CABLE ENTRANCE -

Units up to 3 HP shall be supplied with a cable entrance that incorporates built in strain relief, and a one piece, three way mechanical compression seal with a fatigue reducing cable boot. The pump power cable shall be suitable for submersible pump applications. The power cable on units 5 HP and above shall be field replaceable utilizing standard submersible pump cable. The cable entrance shall incorporate built in strain relief and a combination three way mechanical compression seal with a fatigue reducing / thermal expansion boot. The cable entrance assembly shall contain an anti-wicking block to eliminate water incursion into the motor due to capillary wicking should the power cable be accidentally damaged.